

UNIVERSITY OF OSLO
Department of Informatics

Data Flows in Health Information Systems

**An action research study of reporting
routine health delivery services and
implementation of computer databases in
health information systems**

Juma Hemed Lungo

Master Thesis

2nd May 2003



DATA FLOWS IN HEALTH INFORMATION SYSTEMS

**AN ACTION RESEARCH STUDY OF REPORTING ROUTINE
HEALTH DELIVERY SERVICES AND IMPLEMENTATION
OF COMPUTER DATABASES IN HEALTH
INFORMATION SYSTEMS**

by

Juma Hemed Lungo

**THESIS SUBMITTED AS PARTIAL
FULFILMENT OF THE REQUIREMENTS OF THE DEGREE
“MASTERS OF SCIENCE IN INFORMATION SYSTEMS” AT THE
DEPARTMENT OF INFORMATICS, UNIVERSITY OF OSLO, NORWAY**

DECLARATION

I, Juma Hemed Lungo, declare that

Data flows in health information systems: An action research study of reporting routine health delivery services and implementation of computer databases in health information systems

is my original work and that all the sources that I have used or quoted have been indicated and acknowledged by means of complete references.

juma hemed lungo
2nd May 2003

ACKNOWLEDGEMENT

First, I wish to thank my research supervisor, Prof. Jørn Braa, for his guidance. Thanks to my classmates Faraja, Gertrudes, and Teotónio, I enjoyed their hot discussions and exchanging ideas all the time we have been together. Special thanks are due to my lecturers who actually made it possible: Prof. Jens Kaasbøll, Prof. Judith Gregory, Dr. Knut Rolland, and Prof. Sundeep Sahay, all from the University of Oslo; Dr. Daudi Simba from the University of Dar es Salaam; and Prof. Yussuf Adam from the Eduardo Mondlane University.

To Eduardo Mondlane University, my thanks for accommodation in Mozambique, and thanks to Mr. Paulo Eduardo for translations of my questionnaires. To my housekeeper, Mr. David Zimba, thanks for making coffee for me during the writing of this thesis.

I also wish to acknowledge with thanks personally to Samuel Ngatunga, Wilfred Yohana and Theonas Mkoba from the Ministry of Health in Tanzania; Christian Haule, Omary Dihenga and Wambura from Bagamoyo District Medical Office, Bruno Pióti and António Sitói from the Ministry of Health in Mozambique; Nhampossa, Emilio, and the whole HISP team in Mozambique. I am most grateful to Eurico Romao for his thorough editing.

To my father, Hemed Abdallah Madende, and my mother, Khadija Zuberi Mnese, thanks for your support throughout my life. My son, Hemed Madende, thanks for your patience while I was living away from the family, and I would like to give special thanks to my wife, Tatu Sultan Ally, for her unconditional love, care, and encouragement throughout my career. It is difficult to mention all individuals and appreciate the contributions everyone gave me. I wish to express my sincere gratitude to all those who have helped me in various ways making this research come through.

The research has been generously funded by The Norwegian Agency for Development Cooperation (NORAD) Fellowship Programme. Finally, I would like to mention that the material discussed in this thesis are relevant to the facts obtained during the fieldwork and the conclusions suggested are my opinions based on my professional judgement.

ABSTRACT

This study evaluated the reporting of routine health delivery services and prototyped a computer database, district health information software (DHIS), in the health information systems in Tanzania and Mozambique using case study sites in Bagamoyo district and Gaza province in Tanzania and Mozambique, respectively, from March to August 2002. The purpose of the study was to assess and determine the quality and quantity of reporting of health delivery services; and the benefit, challenges, and conditions for implementing a computer database at the district level of the health information systems in both countries.

The study falls under the framework of action research, where the phases of action research (diagnosis, action planning, action taking, evaluation, and specifying learning) were executed in sequence and cyclically. The diagnosis phase of the study was carried out through interviews, questionnaire, analysis of texts and documents, and participant observations. Appropriate actions were planned. In the action phase, software was developed in order to migrate data from existing computer databases to the DHIS; data were migrated from paper-based databases to the DHIS; and the DHIS was translated into Swahili while adopted in Tanzania. Evaluation of the actions taken was conducted through group discussions and workshops with health workers. To specify learning, reports of the results were prepared and presented to the Ministries of Health for review.

The results were analysed using the DHIS, SPSS computer software, and using content analysis. The findings were presented quantitatively and qualitatively using tables, graphs, figures, photos, and elaboration.

The findings indicated that the health data being reported were not sufficient to support informed decision-making and health planning. The causes of the low quality of the data identified include incomplete, inaccurate, and untimely reporting; lack of resources and office space; existence of legacy information systems; and the existence of parallel reporting systems in the health information systems. The findings also indicated the major challenges in introducing computer databases to be the participation of users and the existing computer database systems. The study demonstrated that the DHIS is suitable software for the health information systems, and that data locked in legacy information systems can be safely extracted and migrated to new information systems.

TABLE OF CONTENTS

DECLARATION	i
ACKNOWLEDGEMENT	ii
ABSTRACT	iii
LIST OF TABLES	vii
LIST OF FIGURES	vii
LIST OF PHOTOS	viii
LIST OF ABBREVIATIONS	ix
CHAPTER 1: INTRODUCTION	1
1.1 Why health information systems?	1
1.2 The research domain area	2
1.3 Relevant previous findings in the research domain area	4
1.4 The research problem	6
1.5 Research objectives	7
1.6 Personal motivation	8
1.7 Intended audience	9
1.8 Research approach	9
1.9 Organisation of the thesis document	10
CHAPTER 2: LITERATURE REVIEW	11
2.1 Information Technology (IT) and Information Systems (IS)	11
2.2 IT in Developing Countries	12
2.3 Information Systems (IS) as Social Systems	15
2.4 Legacy Information Systems	19
2.5 Approaches to information systems development	22
2.6 Efforts to Reform Health Information Systems	27
2.7 Chapter Summary	33
CHAPTER 3: RESEARCH SETTINGS AND RESEARCH METHODS	34
3.1 Research settings	34
3.2 The research design	41
3.3 Methodology	41
3.4 Data collection methods	47

3.5 Data analysis techniques	53
3.6 Justifications of the use of participatory action research methodology.....	55
3.7 Chapter summary	57
CHAPTER 4: APPLICATION SOFTWARE AND DISCUSSION.....	58
4.1 The computer database of the Ministry of Health in Mozambique	58
4.2 DHIS software	59
4.3 Database Filter	61
4.4 The computer database of the Ministry of Health in Tanzania.....	72
4.5 Chapter summary	73
CHAPTER 5: CASE STUDIES IN MOZAMBIQUE AND DISCUSSION	75
5.1 Diagnosis phase	75
5.2 Action planning	75
5.3 Action taking	76
5.4 Evaluation phase	78
5.5 Situational analysis	83
5.6 Progress of HISP project in Mozambique and discussion	94
5.7 Chapter summary	98
CHAPTER 6: CASE STUDIES IN TANZANIA AND DISCUSSION	99
6.1 Design of the research fieldwork	99
6.2 Case study sites.....	103
6.3 Situational analysis	105
6.4 Progress of HISP programme in Tanzania	121
6.5 Chapter summary	126
CHAPTER 7: EMPIRICAL FINDINGS AND DATA ANALYSIS	127
7.1 Combined analysis of the empirical findings	127
7.1.1 Data generation.....	127
7.1.2 Data management	131
7.1.3 Data analysis, transmission, and reporting	138
7.1.4 Uses of health data	147
7.1.5 Feedback and supervision	153
7.1.6 Training	154
7.1.7 Organisation and coordination of reported health data	155

7.1.8 Operation of computer databases.....	156
7.2 General findings.....	159
7.3 Comparative analysis of Tanzania and Mozambique case studies	163
7.3.1 Health information efforts seen as a burden to the health workers.....	163
7.3.2 IT in the health sector is at its infant stage.....	164
7.3.3 Lack of information strategy	164
7.3.4 Poverty	164
CHAPTER 8: KEY FINDINGS AND DISCUSSION	165
8.1 Executive summary of the findings	165
8.2 Problems of the current health information systems	166
8.3 The benefits and challenges for implementing computer databases.....	170
8.4 Lessons from the HISP project network.....	172
CHAPTER 9: CONCLUSION.....	175
9.1 Concluding remarks	175
9.2 The research contributions	176
9.3 Generalisation of the research findings	178
9.4 Limitations of the research	180
9.5 Further research areas	181
9.6 Recommendations.....	182
BIBLIOGRAPHY.....	184
APPENDIX A: INTERVIEW GUIDE QUESTIONNAIRES	194
1. Questionnaire used in Mozambique fieldwork	194
2. Questionnaire used in Tanzania fieldwork.....	196
APPENDIX B: DATA COLLECTION AND REPORTING INSTRUMENTS	199
1. District report for immunisation services.....	199
2. District summary staff report.....	200
3. Antenatal Register	201
4. Health facilities quarterly report.....	202
5. Indicators for the district quarterly report	203
APPENDIX C: FIELDWORK ENTRANCE PROTOCOL.....	204
APPENDIX D: ABSTRACTS OF REPORTS AND PAPERS	205
1. Fieldwork report at José Macamo General Hospital	205

2. Information flows in the HIS in Mozambique.....	206
3. DHIS Training workshop report.....	207
4. Public health 2003 conference paper.....	208
5. Comparison of Extraction Transformation and Loading Solutions	209
APPENDIX E: DISCUSSION OF THE STUDY FINDINGS USING EMAILS....	211
1. Discussion for deliveries data analysis	211
2. Discussion for lack of reporting of health facilities.....	212
APPENDIX F: SPSS OUTPUTS ON ANALYSIS OF THE QUESTIONNAIRE..	214

LIST OF TABLES

Table 3.1: Comparison between Tanzania and Mozambique research settings	40
Table 3.2: Different uses for four methods in qualitative and quantitative research	46
Table 3.3: Methods of Qualitative Research.....	47
Table 4.1: Names of health data elements in SISPROG and DHIS.....	63
Table 4.2: Data fields and names of health facilities in the DHIS.....	63
Table 4.3: Data fields and codes of health facilities in the SISPROG.....	63
Table 4.4: DHIS Import file headers.....	67
Table 5.1: Chibuto district health office: Reporting of health facilities	88
Table 7.1: The MTUHA Outpatient Register	134
Table 7.2: Availability of data analysis tools in health facilities	139
Table 7.3: Availability of medical recorders in the health facilities.....	140
Table 7.4: Bagamoyo health facilities overview.....	144
Table 7.5: An outstanding health facility data	144
Table 7.6: Trend of reporting as a district is located far from the city.	145
Table 7.7: Availability of computers	150
Table 7.8: Means of information dissemination	151
Table 7.9: Feedback responses	154
Table 7.10: SISPROG data file structure.....	158
Table 7.11: MTUHAPROG data file structure	158
Table 7.12: Coverage Indicators for Bagamoyo district.....	161

LIST OF FIGURES

Figure 1.1: Posto de Saúde de Julius Nyerere.....	1
Figure 2.1: Evolutionary development	24
Figure 2.2: HISP Network	31
Figure 3.1: Timeline of the study.....	41
Figure 3.2: Action research cycle	44
Figure 4.1: Database Filter system architecture.....	64
Figure 4.2: SISPROG and DHIS integrated by Database Filter ETL system.....	65
Figure 4.3: Database Filter connected to the SISPROG and DHIS databases.....	65

Figure 4.4: Mapping health facilities from SISPROG to DHIS	66
Figure 4.5: Mapping data elements from SISPROG to DHIS	66
Figure 4.6: Extracting data modules	67
Figure 4.7: Date creator	68
Figure 4.8: Data extracted from SIS previewed on the ETL software.....	69
Figure 4.9: ETL software export commands	70
Figure 4.10: phases of action research cycle in Mozambique	74
Figure 5.1: SISPROG main screen	91
Figure 6.1: Bagamoyo District Health Facilities 2002 Map.....	102
Figure 6.2: Organisational pyramid of the Tanzania health services structure.....	106
Figure 6.3: Structure of MTUHA district-processing file (DPF)	113
Figure 6.4: Health management information reporting system in Tanzania	115
Figure 6.5: MTUHAPROG reported bugs.....	119
Figure 6.6: MTUHAPROG bugs related to health facility data file.	120
Figure 6.7: About HISP Tanzania.....	121
Figure 6.8: DHIS main form in Swahili language	122
Figure 6.9: Quarterly report data from Bagamoyo district hospital on the DHIS	123
Figure 7.1: Comparison of attendance and re-attendance in SIS records.....	133
Figure 7.2: Xai Xai Maternity data from 1999 to 2001.	135
Figure 7.3: Comparison of total deliveries with BCG immunisation	136
Figure 7.4: Comparison of BCG data with Polio data.....	137
Figure 7.5: ANC clients as percentage of all deliveries.....	137
Figure 7.6: Record of Bagamoyo health facilities reporting.....	143
Figure 7.7: Bagamoyo registered cases as percentage of target population	146
Figure 7.8: Health data processing at health facility level.....	153
Figure 7.9: Comparison between Deliveries at HF and Deliveries by TBA	160
Figure 7.10: Coverage Indicators for Bagamoyo district.....	162
Figure 7.11: Vicious circle of poverty in HIS.....	164

LIST OF PHOTOS

Photo 3.1: Programming ETL software	49
Photo 5.1: Learning SIS database system at Gaza province.....	77
Photo 5.2: Participation of the provincial health officers	77
Photo 5.3: Manjacaze district directorate of health and rural hospital	80
Photo 5.4: Chibuto district health directorate and rural hospital	81
Photo 5.5: Bilene district health directorate and rural hospital.....	82
Photo 5.6: DHIS Training at Xai Xai district	82
Photo 5.7: SISPROG and BESPROG are both on old computers	93
Photo 6.1: Meeting with Bagamoyo district medical officer.....	103
Photo 6.2: DHIS Training Workshop in Bagamoyo district	124
Photo 6.3: Participants of the first HISP presentation	125
Photo 7.1: File store	132
Photo 7.2: Analysis of health data using computers	147

LIST OF ABBREVIATIONS

AMMP	Adult morbidity and Mortality Project
BES	Infectious Disease Week Ending system in Mozambique
BESPROG	BES computer database program
CHMT	Council Health management Team
DED	District Executive Director
DHIS	District Health Information Software
DMO	District Medical Officer
DOS	Disk Operating System
DPF	District Processing File
DSS	Demographic Surveillance System
ETL	Extraction, Transformation and Loading
ha	Hector
HF	Health Facility
HISP	Health Information System Programme
HIS	Health Information System
HMIS	Health Management Information System
IDWE	Infectious Disease Week Ending
Km	Kilometre
MoH	Ministry of Health
MTUHA	Mfumo wa Taarifa za Uendeshaji wa Huduma za Afya
MTUHAPROG	MTUHA computer database
NGO	Non-Governmental Organization
PHC	Primary Health Care
RMO	Regional Medical Office
SIS	Sistema de Informação de Saúde
SISPROG	Sistema de Informação de Saúde Program
Sq.Km	Squire Kilometre
TBA	Traditional Birth Attendant
USAID	United States Agency for International Development
USD	United States Dollar
VHW	Village Health Worker
WHO	World Health Organisation

CHAPTER 1

INTRODUCTION

1.1 Why health information systems?

If it is believed that information is indispensable for effective management and development of health services and that, furthermore, it has to be meaningful, reliable, accurate, and timely, then health system managers should be ‘keeping an eye’ on the information system and its performance (Sapirie 2000, p.73)

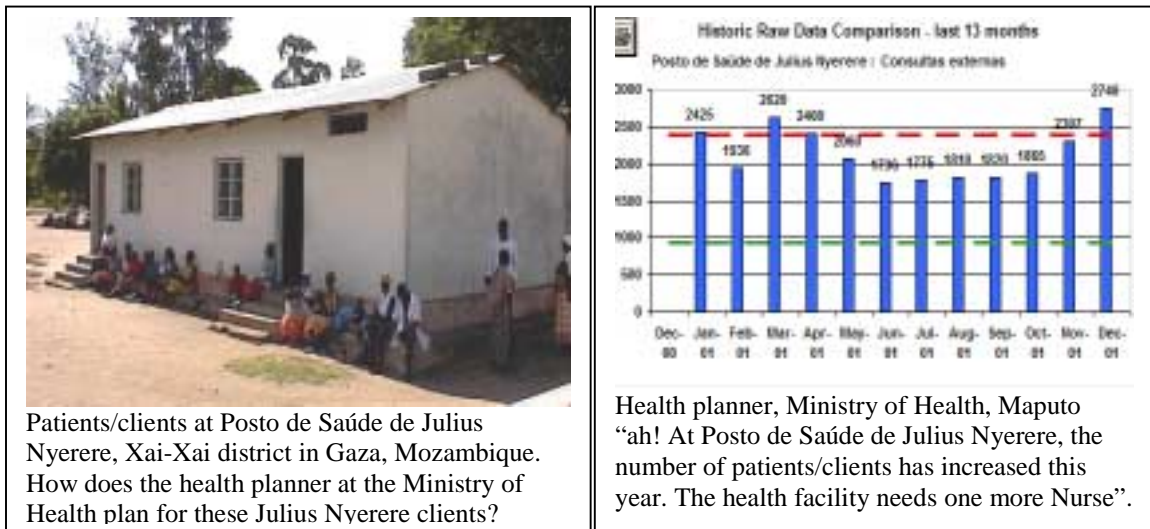

Figure 1.1: Posto de Saúde de Julius Nyerere

Health information systems generate information in order to inform health planners and decision-makers on what is happening at health delivery facilities. Health information systems improve health management and health management is a pre-requisite for good health delivery services. Thus, health information systems are there to bridge the gap between disease occurrence and the response of health workers to fight against diseases.

Wilson *et al.* (2001) defined a health information system (HIS) similarly to a health management information system (HMIS), as “a set of tools and procedures that a health programme uses to collect, process, transmit, and use data for monitoring, evaluation and control in a health system” (Wilson *et al.* 2001, p. 82). A health information system includes, “patterns of belief about the causes of illness, norms governing choice and evaluation of treatment, socially legitimated status, roles, power relationships, interaction settings, and institutions” (Kleinman 1980, p.24). Hardon, states that, “a health system is

not a static phenomena. It is a continuous process of changes due to pressure from both outside the system and from within the system” (Hardon *et al.* 2001, p.27).

1.2 The research domain area

At the beginning, health information systems were oriented to collect information on diseases and on health service outputs. The practice of collecting and maintaining information on health is as old as the history of medicine itself. Since the earliest times, those who were engaged in the art of healing found it necessary to record various outcomes in relation to the number of patients attended. As a result, the health data collected proved to be valuable in all aspects of health care provisions. In contemporary times, health information systems were transcended to the domain of modern health practices, and they hold great significance in the planning and decision-making of health delivery services.

The World Health Organisation (WHO) has long identified health information systems as critical for achieving health for all in the year 2000. A report of a WHO meeting (1987) clearly links improved management to improved health information systems as it argues that, of the major obstacles to effective management, information support is the one most frequently cited (WHO 1987). The supposition, also supported by experience from developed countries, is that improving health information systems will influence good health management. Good health management is a prerequisite for increasing the efficiency and efficacy of health services. As the health sector faces ever increasing demands while receiving decreasing resources, the need to do more with less is especially important. In addition, Tanner and Lengeler (1993) argue that the theoretical effectiveness of health interventions tends to get lost if those interventions are delivered by poorly run health services.

The World Health Organisation has developed HIS assessment approach. The approach of health information systems assessment developed by WHO encourages the selection of subsystems and domains of health information systems for assessment because normally it is not possible to assess all health information subsystems in one study (Sapirie 2000).

Sapirie (2000, p.74) presents the assessment that, “the assessment does not have to be nationwide, but could, for example, focus on one region”. Common subsystems of health information systems are:

- ❑ *Epidemiological surveillance* for notifiable infectious diseases, certain environmental conditions, and risk factors;
- ❑ *Routine service reporting* from the basic health services at community level, health centres, dispensaries, first-level hospitals, referral hospitals, and special and tertiary hospitals;
- ❑ *Special programme reporting systems* such as Tuberculosis Control, Leprosy Control, Malaria Control, Maternal and Child Health and Family Planning, Expanded Programme on Immunization, and HIV/AIDS prevention;
- ❑ *Administrative systems* including health programme budget management, health financial systems, health personnel systems, health supply and logistic systems, health training programmes, health research management, health documentation management, and managing external health resources for health; and
- ❑ *Vital registration* of births, deaths, and migration.

My study is based on the “routine service reporting” subsystem of the health information systems. However, the other subsystems are also highlighted, especially in the case where the other subsystems intersect with my main area of study. In this study, I divided my health information system component (routine service reporting) into categories as categorised by WHO (Sapirie 2000, p.75) as follows:

- ❑ *Data input*: validity and completeness of data recording and collection, including surveillance, routine case and activity data, surveys, data emerging from administrative processes, and registration data;
- ❑ *Data analysis, transmission, and reporting*: efficiency, completeness, and quality of data analysis, processing, and presentation, at all levels of the health system, in order to produce actionable information;
- ❑ *Use of information*: decisions and actions taken for patient/client, community, health unit, programme, and executive management;

- *Information system resources*: availability, sufficiency, and use of critical resource to support: the health information system budget; facilities such as space for record storage, records, and formats; and necessary equipment for data communication, storage, analysis, and document preparation (fax, computers, printers, photocopy machines, etc.); and
- *Information system management*: organization and coordination mechanisms for assuring that data and information are properly defined, standardized, produced, maintained, shared, and reported.

These categories are among of the themes in the analysis of the empirical findings (see Chapter 7).

1.3 Relevant previous findings in the research domain area

Despite the potential that health information systems have, in practice the collection, compilation, analysis, and reporting of health data are riddled with major problems, especially in the context of developing countries. Most health care providers in developing countries equate information systems with filling endless registers, collating, and compiling health data, conducting minimum data analysis, and sending out reports without receiving adequate feedback (Sauerborn and Lippeveld 2000). Furthermore, the data received are often not helpful for health management decision-making because they are incomplete, inaccurate, untimely, obsolete, and unrelated to priority tasks and functions of local health personnel (Braa *et al.* 2001; Sauerborn and Lippeveld 2000; WHO 1987). In other words, information systems tend to be data driven instead of action driven (Sandford *et al.* 1992). In a thesis research study, Wambura (1998) argues that the regional or provincial and district health planners in many developing countries have not been able to analyse and interpret such data for planning, allocating resources for respective health facilities and justifying the requests for resources needed.

In the 1980s, efforts to reform health information systems to systematically collect, analyse, and report data for improved management in developing countries were undertaken by national programme managers of vertically structured programmes. “This was due to foreign assistance to the health sector being typically focused on the

programmes rather than the entire health system” (Sauerborn and Lippeveld 2000, p.6). Many countries decided to attack the problems of health information systems at its roots and planned for a more integrated approach to improving health information systems. Countries like Cameroon (Sauerborn 1991), Chad (Lippeveld *et al.* 1992), Tanzania, (Rubona 2001), Mozambique (Mwaluko *et al.* 1996), and Pakistan (Mujahid 2002) concentrated on routine health information systems for first level care facilities.

The drive for the reform of health information systems coincided with a revolution in information and communication technology, as a result the computer has made its entry even in the most reluctant Ministries of Health. Low-cost powerful computers can efficiently store, process, and transmit enormous amounts of data. Health information systems restructured since the 1980s are computerised to various degrees. However, introducing computer technology in the development of improved health information systems is not necessarily the “silver bullet” that solves the efficiency problems of the health services (Sandiford *et al.* 1992). Many of the resulting computerised systems are suffering from lack of appropriately trained staff, and hardware and software maintenance problems (Brown *et al.* 1999; Sauerborn and Lippeveld 2000)

There is available literature addressing the problems and advising several methodologies and technologies for the development of routine health information systems in developing countries (see e.g. Brown *et al.* 1991; Lippeveld *et al.* 2000; Wilson *et al.* 2001). For example, The Aga Khan Foundation published the Primary Health Care Management Advancement Program Series (Wilson and Sapanuchart 1993), as a set of field guides to strengthen the quality and utility of health data at the local level (district levels and health units). However, those documents have reached a limited target audience, and many are addressing general problems in general contexts. In 1994 and 1995, the World Health Organisation published two documents on the development of district-based routine health information systems namely *Information support for new public health action at district level* and *Conceptual framework and guidelines for the establishment of district-based information systems* (Rodrigues and Israel 1995) respectively. The two documents by WHO give treatment of the design of district-based

health information systems, with a strong emphasis on the use of computer software and hardware. In this study, I address specific problems and in specific contexts, Tanzania and Mozambique. I further intend to give specific solutions to specific health systems; furthermore, I reviewed theories, methods, and technologies from the wide literature addressing the problems of health information systems.

A broad participatory action research project, Health Information Systems Programme (HISP), started in South Africa in 1996 and has spread to other countries including Mozambique, Tanzania, India, and Cuba (Braa *et al.* 2003). HISP demonstrates strong methodologies, addressing how to develop district-based health information systems. HISP is featured by an open source software, District Health Information Software (DHIS), designed for being used at district levels as a health data analysis tool (Braa and C. Hedberg 2002). The argument is that districts should be empowered to be able to analyse and interpret health data. For the districts to be able to do so, HISP argues for a strong decentralisation of the health information systems to the district and sub-district levels. In addition, a computer-based database system should be implemented at the district level to facilitate better storage, analysis, and dissemination of health data. This is important because in many developing countries, Tanzania and Mozambique being examples, their respective health information systems use paper-based databases at the district levels.

1.4 The research problem

This study responds to the question of how to transform existing information systems into management support systems, focusing on the routine services reporting component of the health information systems in developing countries. The rationale behind the approach of improving routine services reporting is based on several existing conditions: First, the problems of inefficient and chaotic data collection and use of information in health facilities and the district levels typically apply to the routine services reporting component of the health information systems. Second, routine services reporting are the only way to generate data for patient and clients management decisions (Sauerborn and Lippeveld 2000) such as ordering supplies, including medicines and supervision of health personnel. This research is aimed at making qualitative and quantitative analysis of the

bottlenecks in health information systems in developing countries using Tanzania and Mozambique as case studies, and discusses suggestions on how these bottlenecks can be addressed. Findings and recommendations of this study are meant to be useful in assisting policy makers and health planners in the two countries. Suggestions in this thesis could provide inputs to processes aimed at improving the quality of health data, which in turn can help to improve the quality of health care delivery. The research questions to be answered in this study are as follows:

- *What are the problems of the current health information systems?*
- *What are the benefits, challenges, and conditions for implementing a computer database at the district level of a health information system in order for it to be used as a health data analysis tool?*

1.5 Research objectives

In this study, my first objective is

- *To assess the routine services reporting in health information systems in Tanzania and Mozambique.*

This requires an understanding of the following questions: who collects data? Where are the sources of data? What are the instruments for collecting data? How and where are data stored? How are data being analysed and transmitted to the next higher level in the health system hierarchy? What are the uses of data? How far can the data support informed decision-making at each level of the health system? What feedback do the lower levels get from the higher levels? What is the status of the operations of the current computer databases in the national health information systems in Tanzania and Mozambique?

The second objective of the research is

- *To prototype a computer database that comes with the HISP project, District Health Information Software (DHIS), at the district level in Tanzania and Mozambique.*

The main activities here are to adopt the software by translating it into Swahili language; installing, configuring, and populating the database with health data; and demonstrate the database to users at the district health offices in Tanzania and Mozambique.

The process of prototyping the DHIS is carried out in collaboration with HISP team members. As I was involved in the HISP project, that opportunity has enabled me to include the third objective of the research as,

- *To identify how learning gathered in HISP network, including from Mozambique, can sensitively be applied to guide the adoption of HISP in Tanzania and other developing countries.*

1.6 Personal motivation

The problems of health management information system include the use of information technology in the health sector and the design and implementation of information systems themselves. There has been a claim that the lacks of computerised systems at the lower levels of a health system such as districts amplify the problem of data analysis and data accessibility. As I came to be involved in the Health Information Systems Programme (HISP), I developed an interest for applying my knowledge of computer science to improve the performance of health information systems. My interest is to develop a common understanding on how health information systems can prove efficiency and what techniques should be used to acquire and implement computerised systems in district health offices. I want to analyse the systems and find out how computer systems can be adopted in the health information systems in order to improve the quality of health data for planning health services. In pursuing this objective, I wanted to contribute to development within this area in my own country, Tanzania, and other countries with similar contexts. The structure of the Masters programme in information system, University of Oslo, has enabled me to do fieldwork in both Tanzania and Mozambique. Carrying out research in two countries has given me an opportunity to make a comparative analysis of my findings. Comparative analysis is essential, especially in drawing general conclusions of the findings.

Before this study, I used to engage in total well-defined and straightforward technical problems, such as programming software, given all the necessary system specifications. In this study, I wanted to complement my experience with a social sciences perspective where one can immerse in the contexts to study the social problems and recommend a more holistic solution. This is because the area of health information systems is new to

me, as I have no background as health professional. I have majored in computer science and mathematics courses when pursuing my first degree. My expertise is in design and implementation of Database Systems and Websites. I have knowledge in programming using Microsoft Visual Basic, Pascal Language, HTML, PHP and designing databases in MySQL, Oracle, Microsoft SQL Server and Microsoft Access Relational Database Management Systems.

1.7 Intended audience

The research is targeted to health workers, graduate students, the Ministries of Health in Tanzania and Mozambique, and computer software engineer professionals. The research contributes to the understanding of the theoretical and practical views in implementing health information systems in developing countries. It is thus of relevance to the information systems research community.

1.8 Research approach

My study is set in two countries, Tanzania and Mozambique, whereby Bagamoyo district and Gaza province were my main study areas in the two countries, respectively. The field research began when I followed a health information systems course at the Faculty of Medicine, Eduardo Mondlane University, in order to gain insight on how health information systems should serve under normal conditions, and to be familiar with medical terminologies. The study falls under the framework of action research. The phases of action research (diagnosis, action planning, action taking, evaluation, and specifying learning) were carried out in sequence and cyclically. The collaboration requirement of action research was fulfilled, as I have carried out this research in collaboration with Ministries of Health in Tanzania and Mozambique and health workers in the case study districts.

The diagnosis phase of the study was carried out through interviews using a qualitative approach, analysis of texts and documents collected in the field, and participant observations. In collaboration with the HISP team members, we planned the appropriate actions to be taken that correspond to the diagnosed problems. In the action phase of the study, I developed application software that extracted data from the national computer

database of the Ministry of Health in Mozambique and load them into the HISP computer database (DHIS). I also contributed to prototyping the HISP database by translating it into Swahili, and demonstrating its use to health workers at the case study districts in Tanzania. Evaluation of the research was conducted through group discussions and workshops with health workers, presentation of the results for review at the Ministries of Health in Tanzania and Mozambique, and at the Faculty of Medicine, Eduardo Mondlane University. To specify learning, reports were prepared and presented at the Ministry of Health in Mozambique and at Eduardo Mondlane University (see Appendix D) and a research paper entitled, “Legacy Information Systems in Health Management Information Systems: A case study from Mozambique” (Lungo 2003) was presented at the “Public Health 2003 Conference, Cape Town 24-26 March 2003”.

1.9 Organisation of the thesis document

The thesis is arranged in the following order. Chapter 1 introduces the research questions, objectives, and the statement of the research problem. In Chapter 2, I present the theoretical part of the research reviewed from the literature study. Chapter 3 presents the research methodology and introduces the research cases. Chapter 4 introduces software applications studied. Chapter 5 describes the case studies in Mozambique, including description of the health facilities and situational analysis of the health information system in Mozambique. Chapter 6 presents the same information as Chapter 5 does but for the case of Tanzania. Chapter 7 presents a combined and comparative analysis of the empirical findings of the research. Chapter 8 presents the key findings and discussion. Chapter 9 presents the concluding remarks, contributions, limitations, further research areas, and recommendations. At the end of the thesis, I have attached appendices. Appendix D presents five abstracts of reports and unpublished papers written through this study, Appendix E presents some emails posted during the discussion of the research findings conducted using emails, and Appendix F, displays the questionnaire results analysed using an SPSS statistical package.

CHAPTER 2

LITERATURE REVIEW

This chapter presents the research theories and concepts I derived from various works in relevant literature. The chapter starts with the definitions of Information Technology (IT) and Information Systems (IS) as this thesis is based on the use of IT in health information systems (HIS). Then, the discussion of IT in developing countries follows the definition section. Information Systems as social systems discussion is the subsequent section of the chapter, which gives a background on why old and large information systems (legacy information systems) do exist in many information systems despite the existence of new powerful technologies. The discussion of legacy information systems is in itself form a chapter section where a proposal on how to develop a new system in order to relinquish the legacy systems is discussed. As an expansion of the proposal on how to relinquish the legacy systems, approaches to information systems developments are described as one of the strategies towards health information systems reform. The chapter ends with a section that summarizes the main theories and concepts found in literature studies.

2.1 Information Technology (IT) and Information Systems (IS)

The terms IT and IS have been used by various researchers over the years. Heeks (1998) defines IT and IS as follows: “*Information technology (IT)* is computing and telecommunications technologies that provide automatic means of handling information. IT is therefore taken here to represent equipment: both the tangible hardware and the intangible software. *Information systems (IS)* are systems of human and technical components that accept, store, process, output, and transmit information. Information systems may be based on any combination of human endeavours, paper-based methods and IT” (Heeks 1998, p.5). This emphasises that IS are just not technical systems, but represent also a larger network of people, practices, and organisations.

In health information systems, when discussing information technologies (IT), usually the discussion is about the use of computers in health information systems. Wilson and Smith (1991 cited Wilson 2000) suggest that, “the creative use of microcomputer technology is

one of the most promising means of improving the quality, timeliness, clarity, presentation, and use of relevant information for primary health care” (Wilson, 2000, p. 199). Recent experience (Braa and C. Hedberg 2002; Wilson 2000; Wilson *et al.* 2001) attests to the potential for using computers in health information systems. However, Wilson (2000) gives a warning that, “it is important to ensure that, computerisation of health information systems does not dominate the health information system reform improvement process” (Wilson 2000, p.199). This is because the majority of health information users in developing countries have no access to computer technology, thus the development and improvement of manual systems for collection, analysis, and use of data should be the primary focus.

While developing countries were reluctant to accept information and communication technologies (ICT) in 1960s and 1970s, in recent years they have come to realise that “ICT has come to constitute the basis of economic development both at the macro and micro levels, and hence those actors that fail to participate in such developments risk increasing marginalisation” (Spanos *et al.* 2002, p.659). As a result, many developing countries are attempting to deploy IT in various facets of governance, and health is a key focus area. It could be argued, however that, even as IT in business organisations around the world converge, the impact of their use may well depend on national culture and the specific idiosyncrasies of the economic and organizational environments in which they are embedded. Because of the differences of the use and the capacity of developing countries to absorb IT, specific studies are important.

2.2 IT in Developing Countries

IT in developing countries is typically characterised by poor infrastructure, inadequate human resources, and lack of an information culture. However, there are indications that these conditions may be gradually changing, and many developing countries have in recent years observed a strong increase of adoption of various ICT applications. While discussing Information and Communication Technology (ICT) in Africa in a Television programme “African Business Tonight”, the commentator, Pater, said that, “ICT application is increasing in Africa; recently, the continent has experienced growth of

Internet Service Providers (ISPs), satellite communications, increase of fixed lines and radio broadcastings” (Pater 2003). Another vivid example is the case of Tanzania. Tanzania’s “ujamaa” policies of self-sufficiency and limited use of non-indigenous technologies, including the 1974 import ban on computers, have had a strong negative effect on the adoption of IT. However, computer acquisitions and applications in the country have increased significantly since the mid 1980s onwards. This development was further accelerated after the import control order was formally revoked in 1993 (Kimaro and Spletstoesser 2000). In July 2002, the Ministry of Health in Tanzania has distributed computers to all 117 districts in Tanzania to facilitate health data processing efforts at the district medical officers (DMOs). In Mozambique, although only the provinces have officially been provided with computers for health data processing, some district health directorates are now also using computers, primarily for secretarial purposes. Some developing countries like India and Pakistan are more advanced in their IT use. One of the most promising and clearly demonstrated applications for IT in developing countries is in the improvement of health care delivery systems (Mujahid 2002). In Pakistan, for example, Muhajid (2002) reports examples in the use of IT in the health sector as reported to facilitate remote consultation, diagnosis, treatment, and collaboration among physicians.

International aid agencies are often the conduit through which new ICTs are introduced in developing countries, with cultural and socio-economic ramifications. However, regardless of where the IT is going to be adopted, Wood-Harper and Bell (1990) advise aid donor agencies to engage with the following questions while planning technology transfer efforts:

- What information technology (IT) is available?
 - What can be supplied in country X?
 - What are the environmental limitations?
 - What local support is available?
 - What degree of training is necessary?
- (Wood-Harper and Bell 1990, p.23)

Without this information, there is little possibility of understanding the degree of IT adoption, which is useful or possible in a particular developing country.

Wood-Harper and Davies (1990) describe three world 'views' in information systems development: sociological; datalogical; and computational. The sociological view is described as follows:

A conceptually holistic set of complexly interrelated notions which effect [SIC] each other in reciprocal manners; these notions are highly esoteric in that they are necessarily implied in human communication as political, power referential, sentential [SIC], psychologically temporal, sociologically contractual, and culturally symbolic properties of the signs, symptoms, and symbols of purposeful human organisation. With this view, human action is the central to the notion of information systems (Wood-Harper and Davies 1990, p.65).

The datalogical view, which the authors argue is most widely accepted amongst practitioners of information systems analysis and design, is described as follows:

An holistic set of complexly interrelated entities which effect [SIC] each other in connected manners; these entities behave in a functional and purposeful manner and thus display a rational and logical process which indicate that the flow of such entities, and their structural forms, constitutes a composite picture of a work task. These may have actual temporalities in the form of life histories but are usually both time and context free (Wood-Harper and Davies 1990, p.65).

The computational view, which is most commonly favoured by computer programmers, is described as follows:

A holistic set of complex interrelated subset which effect [SIC] each other in formulated manners; these subsets comprises elements of a problem which have particular structure arrangements which are restricted in expression by the forms of the computational languages being used. The notation of these languages create a certain bounding of the world of the problem which is always a world of pure forms and such pure forms are represented in the notations. In this pure form they constitute information. That is, the world of information is equated with the world of computer programming (Wood-Harper and Davies 1990, p.66).

Since most information systems incorporate the use of IT, there is a need to address information systems as social systems, so that the actions of the people involved are primarily acknowledged. In this study, I am regarding information technology to be more than just equipments because infrastructure, technical and managerial skills are needed in order to operate it. For example, computer databases in health information systems need personnel who are dedicated to the operation of the system, but also need a political and

legal, to mandate on the use of the computer system. Thus, in my case, the adopted view of information systems is the sociological view.

2.3 Information Systems (IS) as Social Systems

The problems of implementation of information systems are well known and invariably they concern the interplay of human, organisational, and technical factors, which cannot be easily separated. Walsham *et al.* (1988), describe this complex interlinking by conceptualising computer-based information systems as social systems in which technology is only one of the elements. Information systems are not technical systems, which have behavioural and social consequences, but are social systems which rely to an increasing extent on information technology for their functions (Hirschheim 1985 cited Walsham *et al.* 1988). Walsham *et al.* encourage us to understand that, information systems development, equally, is a social process, which involves the use of information technology as part of that process (Walsham *et al.* 1988).

Bjørn-Andersen *et al.* (1990) argue that, “manufacturers and vendors of Information Technology and Information Systems tend to focus primarily on technical issues for solving the “information” problems in developing nations. In reality, the most urgent problems are not technical, but concern the management of this technology” (Bjørn-Andersen *et al.* 1990, p.16). Information technology is often confused with computer applications that are designed to improve efficiency by automating manual systems and are justified by saving from the replacement of human labour. Since many developing nations are “labor-rich”, any technology that adversely affects the already high unemployment rate can be viewed as politically unwise investment (Bjørn-Andersen *et al.* 1990).

Information systems are much more than computers and telecommunications equipment, as they involve also people and their actions in the organizational settings in which they work (see Heeks 1998). It is thus important to account for the people and the implications of their actions in the study of information systems, whether the system under study is a manual or a computer-based system. Walsham *et al.* (1988) argue that “computer-based

information systems are often taken to be technical systems and behavioural and organisational issues are relegated to a secondary role or are not considered at all” (Walsham *et al.* 1988, p.189). This argument is supported by Heeks (1998), who writes that IT on its own does not do anything useful; in order to do anything, it must become part of an information system.

Kling (2000), defines social informatics as “the new working name for interdisciplinary study of the design, uses, and consequences of information technologies that takes into account their interaction with institutional and cultural context” (Kling 2000, p.217). Kling proposes approaches from the social systems perspective, includes the use of “web models”, which provide a framework for information systems in incorporating their context, infrastructure and history. The basic tenet of “web models” (Kling and Scacchi 1982 cited Walsham *et al.* 1988) is that a computer system is best conceptualised as an ensemble of equipment, applications and techniques with identifiable information processing capabilities. Each computing resource has costs and skill requirements which are only partially identifiable; in addition to its functional capabilities as an information processing tool it is a social object which may be highly charged with meaning. There is no specially separable ‘human factor’ for information systems: the development and routine operations of computer-based technologies hinge on many human judgements and actions, often influenced by political interests, structural constraints, and participants’ definition of their situations. The network of producers and consumers around the focal computing resources has been termed as the ‘production lattice’ (Walsham *et al.* 1998) the interdependencies in this network form the ‘web’ from which the model derives its name. The production lattice is a social organisation which is itself embedded in a large matrix of social and economic relations (‘macrostructures’) and is dependent upon a local infrastructure. According to “web models”, these macrostructures and local infrastructures direct the kind of computer-based service available at each node of the production lattice, and since they evolve over time, computing developments are shaped by a set of historical commitments. Thus, “web models” view information systems as “complex social objects constrained by their context, infrastructure and history” (Kling and Scacchi 1982 cited Walsham *et al.* 1988, p.194).

As my study is on health information systems domain, health information systems are also seen as social systems implemented in the health sector. Braa *et al.* (1999) describe health information systems as complex systems because they tend to be deeply embedded in social work practices. Braa (1999) argues that, “working with data and information within the health sector includes filling in forms and registers, collating data into aggregated forms, statistics and reports and the reporting of these to higher levels are tasks that make up important aspects of most health workers’ jobs” (Braa *et al.* 1999, p.4). Health information systems are complex systems and are social systems as they tend to be deeply embedded in social working practices. Lippeveld and Sapirie advise a successful way of designing and implementation of health information systems, by arguing that “the success of a health information systems reform depends not only on technical improvements but also on in-depth understanding of political, socio-cultural, and administrative factors” (Lippeveld and Sapirie 2000, p.249).

Anderson and Aydin (1994) outline three models of change prevalent in information systems research, which helps computer systems evaluators to recognise their own implicit assumptions. As I was assessing the current computer databases of the national health information systems (NHIS) in Tanzania and Mozambique, I found these models very useful. The models are outlined as follows:

- *The computer system as an external force.* This is the simplest approach where the computer system is viewed as an external force that brings about change in the behaviour of individuals and organisational units. Information systems are developed to support managerial goals. “Participants who are expected to use the new technology are viewed as passive, resistant, or dysfunctional if they fail to use the system” (Anderson and Aydin 1994, p.9).
- *System design determined by user information needs.* In this view, the information system is considered endogenous to the organisation with organisation members having control over the technical aspects of the system and the consequence of its implementation. “According to this theory, change occurs in a traditional fashion as needs are identified and problems solved” (Anderson and Alydin 1994, p.10).

- *Complex social interactions as determinants of system use.* A third theoretical perspective holds that complex social interactions within the organisation determine the use and impact of computer systems (Kaplan 1991; Kling and Scacchi 1982 cited Anderson and Aydin 1994; Markus and Robey 1988; Rogers 1983 cited Anderson and Aydin 1994). According to this view, “the way technology is ultimately implemented and utilised in a particular organisational setting depends on conflicting objectives, preferences, and work demand” (Anderson and Aydin 1994, p.10). From this view point, predicting organisational change resulting from information systems requires an understanding of the dynamic social and political processes that occur within organisations as well as the characteristics of individuals and the information systems. The prediction of outcomes requires knowledge of the processes that occur during system planning, implementation, and use (Anderson and Aydin, 1994).

The discussion of information systems as social systems encourages researchers to view health information systems beyond technical perspectives. Regarding health information systems as social systems stresses also that the valid theoretical assumption while implementing and assessing computer systems in health information systems is that *complex social interactions are determinants of system use* as outlined above. While studying health information systems in Tanzania and Mozambique reported in this thesis, I had to find out how the culture and lifestyle of the people in the area of study influence to the many reported problems of implementation of health information systems reform.

The reluctance to change the current health information systems, is a social problem prevailing in many information systems. As a result, many information systems remain unchanged with old computer systems developed using obsolete design and technologies. These old systems are given the name “legacy information systems” (Sommerville 2001, p.582).

2.4 Legacy Information Systems

Many of today's computer systems, used in applications ranging from corporate accounting to air traffic control, were created decades ago, and over the years were patched and fine-tuned to perform their jobs. Sommerville (2001), argues that,

“Many computer software in large information systems remain in use for more than 10 years and are still business-critical, that is, the business relies on the services provided by the software and any failure of these services would have a serious effect on the day-to-day running of the business” (Sommerville 2001, p.582).

Sommerville describes legacy information systems as “socio-technical computer-based systems, that include software, hardware, data, and business processes” (Sommerville 2001, p.583).

Legacy information systems are typically too slow, unreliable, and inflexible for handling new, more diverse and demanding tasks. Unfortunately, the functions of these systems are very difficult to understand, and their replacement with a new and efficient designed system seems virtually impossible. Replacing a legacy information system is a risky business strategy for a number of reasons (Sommerville 2001):

1. There is rarely a complete specification of the legacy information system. The original specification may have been lost. Therefore, there is no straightforward way of specifying a new system, which is functionally identical to the system that is in use.
2. Business processes and the ways in which legacy information systems operate have been designed to take advantage of the software services and to avoid its weaknesses. If the system is replaced, these processes will also have to change, with potentially unpredictable costs and consequences.
3. Important business rules may be embedded in the software and may not be documented elsewhere.
4. New software development is itself risky, so that there may be unexpected problems with new system. It may not be delivered on time and for the price expected.

In describing problems of running legacy information systems, Sommerville (2001, p.583) points to the following expenses in changing legacy information systems:

- Different teams have implemented different parts of the systems. There is, therefore, no consistent programming style across the whole system.
- Part or all of the system may be implemented using an obsolete programming language. It may be difficult to find staff who have knowledge of these languages and expensive outsourcing of system maintenance may be required.
- System documentation is often inadequate and out of date. In some cases, the only documentation is the system source code. Sometimes the source code has been lost and only the executable version of the system is available.
- Many years of maintenance have usually corrupted the system structure, making it increasingly difficult to understand.
- The data processed by the system may be maintained in different files, which have incompatible structures. There may be data duplication and the data itself may be out of date, inaccurate, and incomplete.

2.4.1 Leveraging legacy systems

Thinking about taking action to leverage legacy systems, Chislenko (1995, pp. 2-3) has advised five techniques:

1. *Parallelism and Specialization* where the increased responsibilities of a legacy information system are divided among a number of old systems. The work is substantially improved as individual systems are optimised for performing particular tasks and relieved from other duties.
2. *Redundancy* where several systems work in parallel then the result is compared to make the output more reliable.
3. *Wrapping* where the layers of the system that cannot be understood are left alone while the others are replaced.
4. *External aids* technique deals with providing the legacy system with necessary resources, pre-processing them for the input, and performing some tasks the old system is not good at.
5. Finally, *replacement of parts* technique in those cases where the structure and function of some of the part of the system is well understood. The part can then be directly replaced with its improved equipment (Chislenko 1995, pp.2-3).

Although the above approaches by Chislenko (1995) proved useful in updating many computer systems, these have proved to be a temporary solution and sometimes magnify the problem. In his paper labelled *Reengineering work: do not automate, obliterate*, Hammer (1990) argues,

It is time to stop paving the cow paths. Instead of embedding outdated processes in silicon and software, we should obliterate them and start over ... use the power of modern information technology to radically redesign our business processes in order to achieve dramatic improvements in their performance (Hammer 1990, p.104).

The best option is to replace the legacy information systems with new systems. This is because it is risky to run legacy systems as outlined in the earlier discussion and because since legacy systems were developed in old technologies, as time goes, the hardware and software will fail. However, replacing the legacy systems is also a risky activity as it was presented in the earlier discussion, but this will ensure the sustainability of the organisation, as the new systems are implemented in modern technologies. While developing a new system to replace the legacy one, the most risky aspect is to loose organisation data collected for several years. The question is how the vast amounts of data locked in legacy systems can be secured and migrated to the new system.

2.4.2 Migrating data from legacy information systems to a new information system

Instead of adding patches to the old system as discussed in section 2.4.1, a guaranteed solution is to implement a new system and migrate all the data from the legacy system to the new system. This is common practice in building data warehouse systems as these systems aim at creating an enterprise reservoir of data, that is, integrate all operational systems and store their data in one place, the data warehouse. The process of migrating data from one system to another has a known technical terminology *Extraction, Transformation and Loading (ETL)* (Microsoft 2000).

While ETL can be done manually through “copy and paste” for a simple problem, it is impossible to migrate data from one database to another manually. The alternative is to automate the ETL processes by developing an application software system. Microsoft (2000, p.2) outlines four distinct functional elements of an ETL system: extraction, transformation, loading and meta data whereas;

- ❑ The ETL extraction element: is responsible for extracting data from the source system. During extraction, data may be removed from the source or a copy made and the original data retained in the source system.
- ❑ The ETL transformation element: is responsible for data validation, data accuracy, data type conversion, and business rule application. It is the most complicated of the ETL elements.
- ❑ The ETL loading element: is responsible for loading transformed data in the target system, and
- ❑ The ETL meta data element: is responsible for maintaining information (meta data) about the movement and transformation of data. It also documents the data mapping used during the transformations.

Developing an ETL system seems to be the most feasible solution for leveraging legacy database because it gives users an opportunity to implement new technologies, without worrying of losing their data. The next section discusses approaches to Information Systems development in order to give an insight on how to develop the new systems that will replace the legacy information systems and to develop the ETL application systems.

2.5 Approaches to information systems development

Computer based information systems development approach is concerned with all aspects of the development and evolution of complex systems where software plays a major role. These aspects include hardware procurements, policy and process design and system deployment as well as the software engineering. Software engineering is an engineering discipline, which is concerned with all aspects of software production from the early stages of specification through to maintaining the system after it has gone into use. To develop software, there are known processes that need to be executed. A software process is a set of activities and associated results, which produce a software product. Software processes have four common fundamental process activities. These activities are (Sommerville 2001, p.8):

1. *Software specification:* The functionality of the software and constraints on its operation must be defined.
2. *Software development:* The software that meets the specification must be produced.
3. *Software Validation:* The software must be validated to ensure that it does what the customer wants.
4. *Software evolution:* The software must evolve to meet changing customer needs.

Different software processes organise these activities in different ways. A software process model is a simplified description of a software process, which presents a particular perspective, an abstraction of the actual process being described. There are a number of different general models or paradigms of software development; Sommerville (2001, p.9) outlines the following models:

1. *The waterfall approach:* This takes the software process activities and represents them as separate process phases such as requirements specification, software design, implementation, testing and so on. After each stage is defined, it is 'signed off' and development goes on to the following stage.

2. *Evolutionary development*: This approach interleaves the activities of specification, development, and validation. An initial system is rapidly developed from very abstract specifications. This then refined with customer input to produce a system, which satisfies the customer's needs.
3. *Formal transformation*: This approach is based on producing a formal mathematical system specification and transforming this specification, using mathematical methods, to a program.
4. *System assembly from reusable components*: This technique assumes that parts of the system already exist. The system development focuses on integrating these parts rather than developing them from scratch.

The discussion regarding information systems as complex social systems (see section 2.3), suggests that, it is not possible to elicit all user requirements at one phase of software development thus the *waterfall approach* is not appropriate for developing health information systems. The problem with the waterfall model is its inflexible partitioning of the project into these distinct stages; implying that it should only be used when the requirements are well understood. The *formal transformation* approach has something in common with the waterfall model but the development process is based on formal mathematical transformation of a system specification to an executable program. The formal transformation approach requires that the problem is well defined so that a mathematical representation of the operation of the software is specified in advance. This is not always the case in building software for health information systems because it is unlikely to have health delivery practitioners who know the system very well and have a competitive knowledge in software development. The other approach, *system assembly from reusable components*, is also not a good choice for developing software for HIS because usually there are no existing systems in the field. For example, the case of Tanzania and Mozambique, the district medical office has a paper based system. Even if there are existing systems, usually these are legacy systems developed using obsolete technologies. Thus, the feasible choice is the *evolutionary development* approach; because the assumption is that, a software process can be developed incrementally. "As users develop a better understanding of their problems, this can be reflected in the software system" (Sommerville 2001, p.47). The evolutionary development approach is based on the idea of developing an initial implementation, exposing this to user comment

and feedback, and refining this through many versions until an adequate system has been developed. Figure 2.1 presents evolutionary systems development process activities.

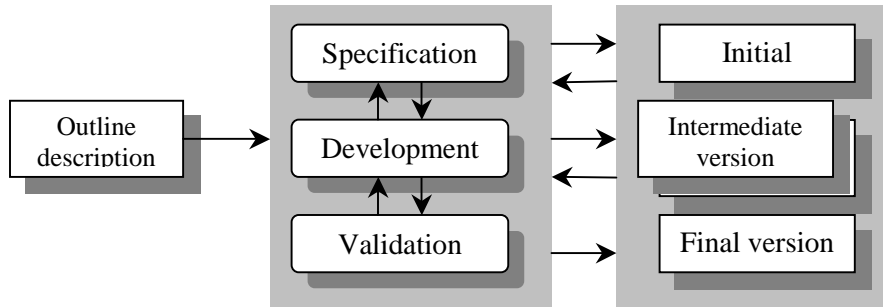

Figure 2.1: Evolutionary development (Source: Adapted from Sommerville 2001, p.47)

Evolutionary development approach introduces *system prototypes* in order to allow users to experiment to see how the system supports their work. A prototype is an initial version of a software system which is used to demonstrate concepts, try out different design options and, generally, to find out more about the problem and its possible solutions. A software prototype supports two requirements engineering process activities “requirement elicitation and requirements validations” (Sommerville 2001, p.172). Experiments have shown (Boehm and Gray 1984) that prototyping reduces the number of problems with the requirements specifications. Furthermore, the overall development costs may be lowered if a prototype will be developed. Once a prototype is available, it can also be used for other purposes (Ince and Hekmatpour 1987) such as:

- ❑ *User training.* A prototype system can be used for training users before the final version of the system has been delivered.
- ❑ *System testing.* Prototype can run ‘back-to-back’ tests. The same cases are submitted to the prototype and to the system under test. If both systems give the same result, the test case has not detected a fault, otherwise it may mean that there is a fault and the reason for the different should be investigated.

Prototyping in evolutionary systems development allows and depends on user participation (involvement). User participation in information system development is recommended to systems analysts as a technique of successful system development.

Newman and Noble (1990) defined user involvement as “a process of interaction between systems specialists and users or their representatives where they discussed four process models of user involvement-learning, conflict, political and garbage-can” (p. 89). From a study of the literature, the four process models of user involvement in systems development abstracted by Newman and Noble are now described.

The Learning model: The “simplest variation” of the learning model sees user involvement as “an opportunity for designers to educate users about the system” (Newman and Noble 1990, p.90). As discussed above, prototypes allow user involvement by providing early training of users. As a result, users’ expectations become more realistic, and their resistance to change is reduced (Bjørn-Anderson and B. Hedberg 1977 cited Newman and Noble 1990). “Success” is user satisfaction with the system, and use of it as the designers intended. The “simplest variation” of the *learning model* falls short in that learning is one-sided; designers have little to learn except details of user requirements.

Another variation of the learning model is the “mutual learning model” (Boland 1978) in which users and software engineers recognise each other’s distinctive capabilities and views, and cooperate in order to produce a joint solution to a common problem. Each side learns from the other in the course of development.

Conflict Model: Conflict models have been developed to explain situations where there are complex problems, incompatible goals, and multiple criteria of success (Robey and Farrow 1982). A test of the model (Robey *et al.* 1989 cited Newman and Noble 1990) showed that user participation led to conflict if it was accompanied by user influence. At the same time that it created conflict, participation coupled with influence created opportunities for conflict resolutions. Here, user involvement is conceptualised as a process through which users and designers discover and resolve their differences. The conflict model appears to be superior to the learning model in that it recognizes the potential, which user involvement has for producing conflict and it sees the amount of influence users have as instrumental in conflict resolution.

Political Model: The organisations into which information systems are introduced are seen as political orders, with established distributions of power, which may be disrupted or confirmed by the design of the technology (Pettigrew 1973 cited Newman and Noble 1990). Kling (1987, p.312) explicitly includes a political model as part of the assumptions for his “web” model of computing in organisations.

Political models take account of conflict but are concerned with the way in which conflict is structured by the existing organisation, and the role of power in conflict resolutions. “Political tactics such as bargaining and negotiations are relevant to conflict resolution” (Newman and Noble 1990, p.93). The HISP implementation in South Africa was not without criticism from HISP partners, which had its roots in conflicts between different levels of the administration. However, the financial and organisational independence of HISP allowed the programme to undertake developments and provide solutions (Braa *et al.* 1999).

The Garbage-Can Model: This model was intended to apply to a particular type of organisation, or decision situation, described as “organised anarchy” (Newman and Noble 1990, p.94) such as universities. In this model, to paraphrase Newman and Noble (1990), actors are seen as having limited rationality in that they are not sure what their interests are and pursue them only intermittently. Key players leave the scene, the composition of the team changes constantly as do the goals. HISs are not structured as organisation anarchy, and thus, the model is not applicable in HIS and hence not discussed in my study.

The discussion of the process models for user involvement in systems development suggest that health information systems practitioners to understand the roles that users can play during the implementation of health information systems. In my study, the political model is the most relevant process model of user involvement followed by conflict model. This is because health information systems are structured as a hierarchy of administrative levels. Many health information systems reform efforts like the case of HISP aims at empowering the lower levels such as the district which has little or no say

in the current systems. Now neglecting to involve the higher administration levels (National and Provincial) would create strong resistance from the higher authority levels in changing the HIS structure. Some personnel from the national and provincial levels should be directly involved in order to negotiate with the lower levels and other stakeholders to accept a new system.

2.6 Efforts to Reform Health Information Systems

There have been many problems reported on the performance of health information system in developing countries (see e.g. Braa *et al.* 2001; Lippeveld *et al.* 2000; McLaughlin 2001; Simwanza and Church 2001). In recent years, many developing countries are restructuring their health information system mostly by decentralising the systems in order to empower the lower levels with focus on the district levels. The process of restructuring the health information systems is commonly known as health information systems reform. In many developing countries, health information systems reform has been one of the national strategic plans. While some countries have undergone comprehensive restructuring of the health information systems as an integrated approach, in others, health information systems reform was done using a more gradual approach on subsystems, such as epidemic disease surveillance or routine services reporting (Wilson 2000). In Tanzania for instance, the former President of the United Republic of Tanzania His Excellency Ali Hassan Mwinyi in a speech presented on the 8th June 1990 was quoted as saying “We need to improve our health information system in order to enable individuals and the government to make sound decisions based on correct information” (MoH-TZ 1993, p.i). Similar health information systems reforms have been reported from South Africa, Zambia, Uganda, Malawi, India, and Pakistan (see e.g. Braa and C. Hedberg 2002; Simwanza and Church 2001; Mursalin and Haque 2001; Wabwire-Mangan *et al.* 2001).

The most radical and important health information systems reforms in Mozambique occurred after independence in 1975 (Mwaluko *et al.* 1996). During that period, the health sector was faced with a shortage of qualified staff, fragmentation and a severe bias towards urban and curative services, and less than 10% of the population had effective

access to health care. Shortly after independence, a 16 years (1976 - 1992) civil war created a severe deterioration of the socio-economic situation in the country, including the health care delivery system. According to Mwaluko, “most of the health units were destroyed, the share of the health sector on the total health expenditures declined from 6.7% in 1980 to 3.0% in 1990. The per capita health expenditure reached a peak of \$4.67 in 1982, but declined to \$1 in 1987 and since then did not increase” (Mwaluko *et al.* 1996, p.4).

Mwaluko *et al.* describe further that, “with the peace agreement in 1992 and the democratic elections in 1994, the new government designed an economic, and social programme, emphasizing National Reconstruction and Rehabilitation of Economic and Social Infrastructures” (Mwaluko *et al.* 1996, p.4). Peace time in Mozambique has made it possible for people to re-establish effective communication with the population in areas formerly cut off by the war and to collaborate with the communities in planning and implementation of programmes intended to help them to improve their lives.

Braa *et al.* 2001 conducted a study of the actual and potential usage of information and communication technology at District and Province levels in Mozambique with a focus on the health sector. That study, revealed the existence of many problems, such as: poor feedback routines from province to district and from district to health facilities, limited local use of information for action, and lack of training and support (Braa *et al.* 2001). Similarly, an assessment of the infectious diseases surveillance systems in Tanzania conducted in year 1999, revealed poor and untimely reporting system. For example, Brown *et al.* (1999) reported that only one quarter of the health facilities visited in the 1999 study to have had submitted complete reports in all the four periods of the year. A review by the Ministry of Health in Tanzania, to assess the performance of Health Management Information System in Tanzania, reported a series of problem issues in the HMIS. These problems included “information efforts seen as a burden to the health workers, inadequate access to health data, poor preparation of data for use, weak analysis of health data, and some information bypassing decision makers” (MoH-TZ 2000, p.11). The reviewers went further to evaluate the existing computer database system installed at

all Regional Medical Offices (RMOs) in Tanzania, being used to assist compilation, analysis, and reporting of health data. They recommended that the HMIS should “solve the regional and national computer disaster, mostly by improving the current software” (MoH-TZ 2000, p.10).

2.6.1 Using computers in health information systems

There is a long list of reasons for using computers in health information systems in the literature. Some of the reasons are as follows:

- ❑ To improve health system efficiency by processing and analysing large amounts of data quickly.
- ❑ To produce a wide variety of outputs and feedback reports targeted for many levels of the health system from a single data set or by combining data set.
- ❑ To reduce the duplication of work, this is typically seen in many hierarchical data collection systems.
- ❑ To improve the quality of data collection through automatic validation during data entry and automatic preparation of immediate feedback reports on errors for individual health facilities.
- ❑ To improve analysis and information presentation to facilitate data interpretation and use for decision-making.
- ❑ To train health personnel through computer-based interactive tutorials for self-instruction and continuing education.
- ❑ To improve data dissemination by providing online public access to data through Internet World Wide Web pages.

In addition to the direct reasons for using computer technology in health information systems, the process of computerisation itself can serve as an opportunity to review and improve dysfunctional manual systems and procedures (Auxila and Rohde 1988).

However, the manner in which IT is implemented in HIS in developing countries has been questioned by many studies, as they are typically featured by large-scale projects. McLaughlin (2001, p.72) criticises that,

“Traditionally HIS efforts have been couched within project components for building health systems, efforts that have produced notorious white elephants and countless reams of paper forms that were hardly used to inform decision-making”.

In addition, Lippeveld and Sapirie (2000) argue that, one of the main objectives of many typical health information systems development projects is the computerisation of important data to be managed, monitored, and analysed. However, whenever computerisation becomes the primary objective of health information systems development efforts, the more important purpose of serving the data needs of the care providers tend to get lost.

McLaughlin describes the strategic approaches used by some developing countries to reform their health information systems, as it was to respond to donor requirements (McLaughlin 2001). Lippeveld and Sapirie (2000) argue that donor driven health information system restructuring is likely to fail.

Although sometimes these projects succeed in getting a new recording and reporting system up and running with a two-year period. However, once the project is terminated, the situation rapidly deteriorates with accumulation of software and hardware maintenance problems, incomplete and delayed reporting, and the lack of continuity of national staff for managing the system (Lippeveld and Sapirie 2000. pp.247-248).

2.6.2 Health information systems reform, the focus is the districts

While restructuring health information systems, many countries focus on decentralising their systems to empower the lower levels in the HIS hierarchy. According to Muquingue *et al.* (2002), national health information systems are built up from the informational activity carried out in multiple, minuscule, often hierarchically insignificant points in the geographical structure of a country; these points are generally districts. The administration structure of many developing countries includes the community (village), district, provincial and national levels. The national health information systems in many developing countries have been strongly based on Primary Health Care (PHC) and the district becomes the most appropriate level for co-ordinating top-down and bottom-up planning, for organising community involvement in planning and implementation, and for improving the co-ordination of government and private health care (WHO 1987).

Being the information and physical hub between the community and the national health information system, the district consists of a large variety of interrelated elements that support the health system in a specific geographical area. A district includes the health care workers and facilities, up to and including first and second referral hospital levels (Amonoo-Lartson *et al.* 1984).

2.6.3 Health Information Systems Programme (HISP)

HISP is a “successful” collaborative programme between the Ministry of Health in Mozambique, Eduardo Mondlane University, University of Dar es Salaam, University of Oslo, Department of Health in South Africa and the University of Western Cape. HISP focuses on the district and sub-district (Braa *et al.* 2003), and one of its activities is to implement a computer database, District Health Information Software (DHIS), in order to be used as health data analysis tool. Although HISP started in South Africa, other countries are in the process of adopting the HISP software and its approaches of developing district health information systems, Tanzania and Mozambique being among the nodes of the HISP network. Figure 2.2 presents the HISP network.

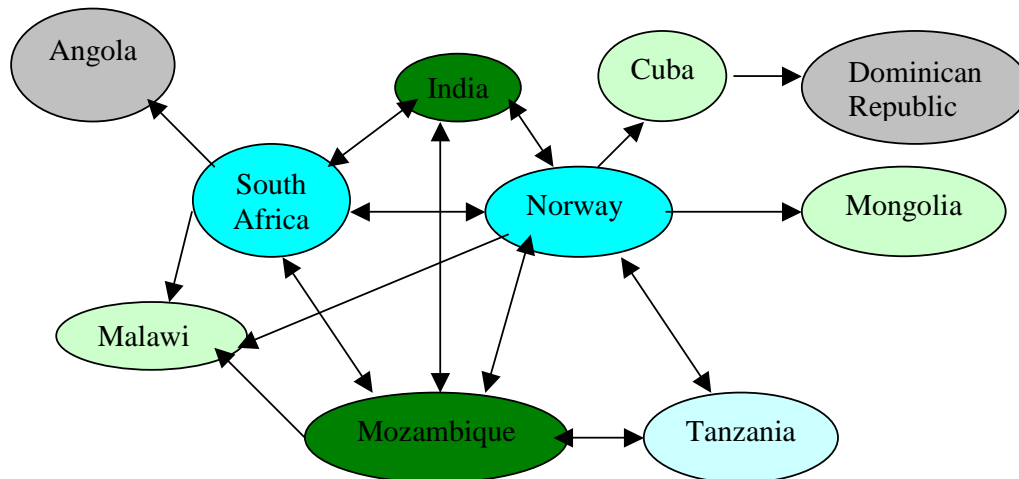

Figure 2.2: HISP Network (Source: Braa *et al.* 2003, p.15)

The link between South Africa and other partner countries is determined in that the HISP software is still being developed in South Africa, and the HISP team in South Africa provides support and guidelines to the partner countries. In addition, HISP projects developments in different countries are fed back to the development team in South

Africa, which supports processes of mutual learning. The two focus areas of research that have been central in the HISP case are (Braa and C. Hedburg 2002):

- The process towards developing standards for primary health care data, and how this process is interrelated with
- The design and development of a district based health information system using a participatory prototyping strategy.

The findings from HISP research revealed that the particular social and historical background of South Africa and the breakdown of apartheid, provided a particularly chaotic context of incompatible and ‘competing’ standards that were defended by a variety of structures and organizations, raising the need to develop standard health datasets. In the design and development of a district based health information system using a participatory prototyping strategy, the research could be argued as a success story because of the diffusion of lessons and products (e.g. software) to new districts and provinces within South Africa through a spread of replicable processes (the similar) and cultivate the processes in each new location (the specific and different, that is, adaptation and appropriation) (Braa and C. Hedberg 2002). The general findings regarding standardization of health data and design and development of a district based health information system in South Africa are useful in the other countries.

In my study, I aimed to find out how best these general findings can be adopted in other countries. Although generally health information systems have the same goal but the context where the system is operating imposes the need for treating each country, and also different districts in a country, as specific cases. In Tanzania and Mozambique, for example, the official languages are completely different from that used in South Africa. Thus, the computer database developed in South Africa was translated into Portuguese and Swahili for Mozambique and Tanzania, respectively. Also, two different districts within a country may differ in terms of ICT infrastructure and computer literacy of health workers.

2.7 Chapter Summary

The most relevant concepts from a review of the literature are that information systems also apply for health information systems are social systems. My research assumption, therefore, relies on the concept that “complex social interactions are the determinants of a new system use” (Anderson and Aydin 1994, p.10). Thus, in introducing a new computer system, user involvement in prototyping is important, as this will allow system developers to interact with users and develop a stronger socially sensitive approach. In addition, obliterating of legacy systems may be considered as an appropriate strategy for alleviating the many risks being imposed by old systems and a discussion on how to move the data to the new system was presented.

CHAPTER 3

RESEARCH SETTINGS AND RESEARCH METHODS

This chapter presents the research case study sites, the research design, the research approach, data collection methods, and data analysis techniques. The research was designed to take place in multiple case study sites. The structure of the master programme I was enrolled to has enabled me to select my case study sites in two countries, Tanzania and Mozambique. The fieldwork was conducted from March 2002 to August 2002 and a steady correspondence has been maintained with key informants from the case study sites through email messages. This research falls under the framework of an “action research” approach. The theoretical assumption behind an action research approach is that action is a way to build theory, knowledge, and practical action by engagement with the world in the context of practice. The main data collection methods were semi-structured interviews (most were audio recorded), participant observation, group discussions, workshops, and analysis of documents. The study evolved around five phases of action research approach namely diagnosis, action planning, action taking, evaluation, and specifying learning. The action-taking part of the study involved the development of an extraction, transformation and loading software, adaptation of District Health Information Software (DHIS), and software end-user training. The chapter is structured as follows: section 3.1 introduces the research settings; section 3.2 presents the research design, section 3.3 presents an action research methodology. Section 3.4 presents data collection methods, and section 3.5 presents data analysis techniques.

3.1 Research settings

The research design strategy was to perform case study in multiple sites. The structure of the University of Oslo Integrated Masters Programme enabled me to perform my study in two countries, Tanzania and Mozambique. In each country, the study involved several health units as case study sites. Three health information software were studied. The software are the national computer database system of the Ministry of Health in Mozambique (known by its Portuguese acronym SISPROG - Sistema de Informação de Saúde Program), District Health Information Software (DHIS), and the computer

database system of the Ministry of Health in Tanzania (known by its Swahili acronym MTUHAPROG - Mfumo wa Taarifa za Uendeshaji wa Huduma za Afya Program). These are now described.

3.1.1 Application software

Sistema de Informação de Saúde Program (SISPROG)

SISPROG is the national computer database system of the Ministry of Health in Mozambique installed at the National Health Information System (NHIS) section of the Ministry of Health and in all Provincial Health Directorates in the country. SISPROG was developed and implemented at the national and provincial levels since 1994. SISPROG was developed on “dBase III” database management system (DBMS).

District Health Information Software (DHIS)

DHIS is an open source software from South Africa, which was introduced in the health information system in Mozambique through the Health Information Systems Programme (HISP) since the year 2000. The DHIS has many functions such as maximum and minimum ranges, validation rules, data definitions, indicators, report generator, a number of modules ranging from PHC to hospital and TB, organisational unit infrastructure, and annual surveys. DHIS was designed to capture health data at the district level of the health information system. In Mozambique, the DHIS is currently being piloted in Niassa, Inhambane, and Gaza provinces.

Mfumo wa Taarifa za Uendeshaji wa Huduma za Afya Program (MTUHAPROG)

MTUHAPROG is the national computer database system of the Ministry of Health in Tanzania. MTUHAPROG was developed on Microsoft Access 97 database management system and was installed in all Regional Medical Offices in Tanzania in the year 2000.

3.1.2 Mozambique case studies

Gaza province

In Mozambique, the study was set in Gaza province. This is because the study involved several districts of Gaza and mainly the Provincial Health Directorate (in Portuguese,

Direcção Provincial de Saúde (DPS)). While carrying out my fieldwork in Mozambique, I worked in collaboration with the HISP team members and sometimes in a group of students whereby the fieldwork was organised by the Eduardo Mondlane University. I therefore did not influence the choice of the fieldwork setting, Gaza province, which was selected because it is a nearby province to the capital city Maputo, and is one of the HISP pilot sites in Mozambique.

Geographical features

Gaza is one of eleven provinces of Mozambique. The provincial capital of Xai-Xai is 224 km from Maputo. The province has twelve districts but the study has included four districts (Xai Xai, Chibuto, Manjacaze, and Bilene). Again, the selection of the districts to carry out the fieldwork was not under my control. However, I realised that the contexts of the districts differ from one another, raising implication for making generalisations of the research empirical findings. For example, Chibuto and Manjacaze districts are located very far from the Provincial Health Directorate and are featured with poor road networks, while Xai-Xai and Bilene are close to the office and are located in the main road from Maputo and are connected by good road networks. The differences in transport and communication infrastructure have direct influence to the reporting of health data.

Gaza has a geographical area of 75,450 square kilometres. It borders Manica province to the north, Maputo province to the south, South Africa to the west, Inhambane province to the east and the Indian Ocean to the Southeast. There is a good road from Maputo, which connects with the roads from Namaacha and Ressano Garcia Borders. It is also possible to travel to Xai-Xai by charter flight from Maputo.

Demography

Gaza province is estimated to have a total population of 1,207,200 in the year 2002; its population density is 16-inhabitants/square kilometres, and most represented ethnic group is Changana. The estimated population for the visited districts of Gaza province in the year 2002 are as follows: Chibuto is 164, 675, Manjacaze is 176,118, Xai Xai is 208,260, and Bilene is 161,093.

Socio-economic profile

Gaza province is known as the "granary" of Mozambique due to the fertility of the Limpopo valley where there is extensive cereal and rice cultivation. The Limpopo River flows to the south of the provincial capital of Xai-Xai in a wide, fertile plain where predominantly rice is cultivated. Other main products include cashew nuts, cotton, cassava, rice, and maize. Apart from agricultural activities, other economic activities are tourism and wildlife activities. Gaza province has many beaches that attract many tourists. Most of the famous beaches are Praia do Xai-Xai, Praia do Chongoene and Praia do Bilene-Macia. The Banhine National Park, situated between the Limpopo and Changane rivers, is an important area, protected due to its rich variety of wildlife. The tourism industry makes employment for many indigenous people in the province. The tourism industry also, provides an opportunity for the farmers to sell their products especially cashew nuts, cassava, honey, and various types of fruits. The contribution of this to the health sector is that most of the people could afford to pay for drugs and other cost-sharing health services in the health facilities. This collected money from cost-sharing in turn could be used by the health system to buy health delivery stationeries and other equipments.

With the flood tragedy of the year 2000, many people had to be relocated to safe highlands for about six months. Although there are many efforts to reform economic activities, there is still a long way to go. Due to water lodging in many places, the inhabitants have suffered a lot with out break of diseases and high rates of malaria cases. Some communication infrastructures have been blocked completely even until now.

The Ministry of Health in Mozambique

The Ministry of Health in Mozambique is located in the capital city, Maputo, at the junction of Eduardo Mondlane Avenue and Salvador Allende Avenue. The purpose of including that setting was to study SISPROG and other computer programs that operate in the health information system in Mozambique. My preliminary findings reports were also presented at the Ministry of Health for review.

3.1.3 Tanzania case studies

The fieldwork in Tanzania involved a number of health facilities in Bagamoyo district located in Coast region. In addition to the health facilities visited at the Bagamoyo district, the study involved Coast Regional Medical Office, the Ministry of Health, and two Non-Governmental Organisations (NGOs). Since the focus was to study data collection, compilation and analysis of health data, the study was based in Bagamoyo district. This district was chosen because of its proximity to Dar-es-Salaam where I live, and because Bagamoyo represents a typical district in Tanzania. As a personal motivation, Bagamoyo district shares one of its borders with my “motherland”, Handeni district, in Tanga region. I speak the same local language as the people in Bagamoyo do, and thus I wanted to study my own people. In addition, Bagamoyo is one hour drive by public transport from Dar-es-Salaam and costs \$1 (one USD).

Geographical features of Bagamoyo district

Bagamoyo is among the six districts in Coast Region. The district shares boarders with Handeni and Pangani districts in the North. In the South, the district shares its boundaries with Kibaha and Kinondoni districts. In the East, it shares boarders with the Indian Ocean, while in the West it shares with Morogoro Rural district.

The climate/weather conditions may have an influence to the reporting of health data. This is because in the rainy seasons several roads are not accessible. The district has a tropical type of climate with an annual temperature of 30⁰ C maximum and 13⁰ C minimum. The average rainfall lies between 800 mm to 1,200 mm per annum. Rainy seasons usually start between Mid- October and December, and also between March and May. Dry season begins in Mid-May ending in Mid-October. During the dry season, the soil becomes hard to cultivate, water for domestic use and livestock becomes an acute problem. In studying the reporting of the health facilities, I traced to compare the months of poor reporting to see if the weather has influenced the reporting of health data.

Population size/Structure

According to 1988 National Population Census, Bagamoyo district had a total population of 173,885 of whom 85,626 (49.2%) were males and 88,259 (50.8%) females and a

population growth rate of 2.5% per annum. The district is projected to have a total population of 240,643 people, 9,626 under one year, 48,129 under five, 96,260 children 0-14 years, and 48,129 women under childbearing age by the end of 2002. Population density of the district is 25 square kilometres and the male to female ratio is 1:1.03.

Education

Bagamoyo district has 63 kindergartens (47 being private-owned), 97 primary schools (1 private school included), 7 Secondary schools, 7 Colleges, and 2 Vocational Training Centres. There are about 37,893 pupils in primary schools, 1,312 students in secondary Schools and 1,500 in Institutions. The enrolment rate of the district is 89.7% of which 48.3% are girls.

Socio-economic profile

The district has 1,607,620 hectares of arable land; of which only 250,000 hectares are used for agricultural activities, which is 16% of potential agricultural arable land. Ninety percent (90%) of population is engaged in agricultural activities. The average farm size per household is estimated at 3.9 hectares (DED 2002). The main cash crops grown are cashew nuts, cotton, coconut, and tropical fruits such as mangoes, oranges, and pineapples. The staple food crops grown include: maize, paddy, cassava, millet, sorghum, simsim, cowpeas, beans, sweet potatoes, and horticultural crops. Other economic activities include mining, industries, and tourism. Although many of the people in Bagamoyo have low incomes, many can afford to pay for the cost sharing in the health facilities. Therefore, in this study, the assumption is that, poor reporting of health data from the health facilities relates to the poor quality of services offered, bad reputation of the health workers, and other reasons. Data reporting problems are treated as a result of poor health management information system and not because people did not go to the health facilities because they could not afford to pay for the health services offered.

Electricity

National Grid System supplied from Kidatu Power Station and supplemented by Mtera Power Station serves Bagamoyo town. Countryside electrification is still at infancy; only 16 villages (20%) out of 82 villages in the district have electricity. Lack of electricity in

many health facilities hinders health delivery activities, as the health facilities have to use kerosene refrigerators to store drugs, which are expensive to run, and are delicate. It also imposes unhygienic problems, for instance, the health tools like scissors and injection pumps have to be boiled using wood fire.

Transportation and Communication Network

There are two airstrips in the district, one at Zinga and one at Sanzale. The district has 2,560 kilometres road network of which about 749 Km (29%) are not accessible during the rainy seasons. Thus, some health facilities are completely blocked during the rainy seasons. An example of these is Saadan Health Centre, located in Saadan Game Reserve, which is impossible to reach during the rainy seasons. This poor access to the health facilities significantly delays the delivery of health reports to the district medical office.

3.1.3 Comparison between Tanzania and Mozambique settings

The comparison of the settings is aiming at generalizing the study findings in case the same phenomena are observed in the two countries. The study involved the regional and national levels of national health information systems in the two countries. Table 3.1, shows the general overview of the case studies in the two countries. The two countries have almost the same level of economic status, communication infrastructures, and population density. To overcome the language constraints, I have used audiotapes to record the structured interviews and my interview questionnaire was translated into Portuguese (see Appendix A.1).

Table 3.1: Comparison between Tanzania and Mozambique research settings

Parameter	Tanzania (Bagamoyo)	Mozambique (Gaza province)
District size (population)	Approx. 241,000	Approx. 100,600
Population density (inhabitants/square kilometre)	Approx. 25/ square kilometre.	Approx. 16
Number of health facilities	42	63 (Bilene =13, Chibuto =9, Manjacaze = 24, xai-xai = 17)
Language	Swahili and English	Portuguese
Transport and comm. infrastructure	Not all roads are good	Not all roads are good

Source: Situational analysis, study fieldwork results, 2002

3.2 The research design

Figure 3.1 shows the time line of my research. The first event from left, “MZ: Course: HIS, DHIS”, is a course I followed at the Faculty of Medicine, Eduardo Mondlane University, that gave me a theoretical background of how health information systems operate and the functions of the DHIS software. The last but one event, “MZ: DHIS Training workshop”, is a DHIS Training Workshop, organised by the Ministry of Health and the HISP Team in Mozambique to train health workers from Gaza province, in September 2002.

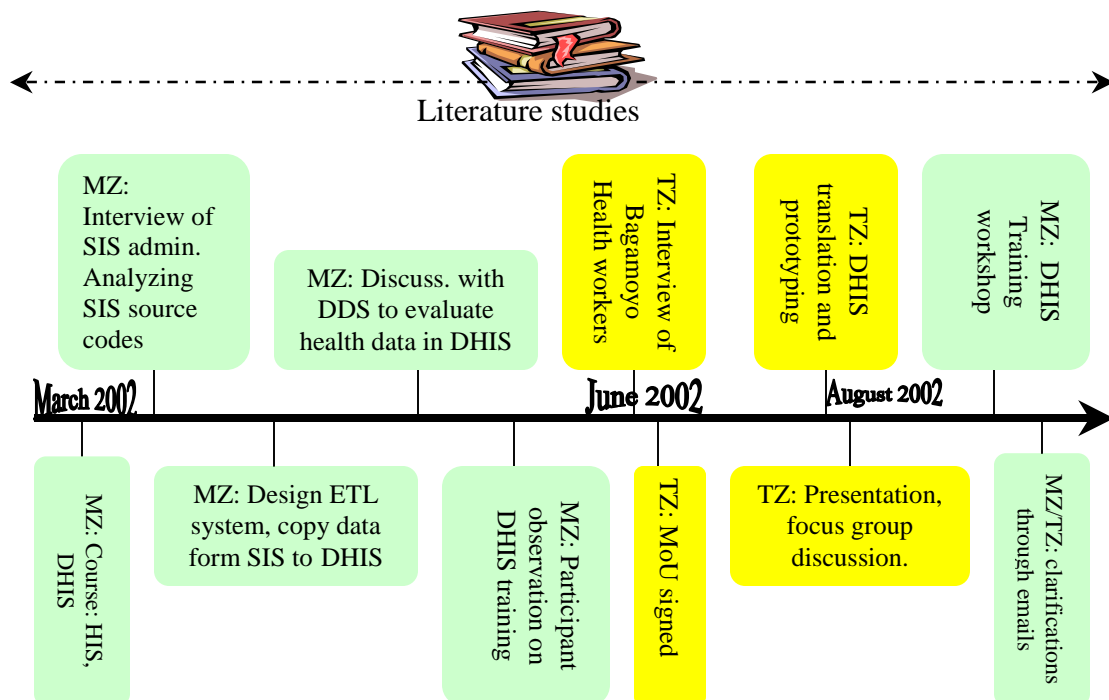

Figure 3.1: Timeline of the study

DDS – District Directorate of Health; DHIS – District Health Information Software
 MZ – Mozambique; MoU – Memorandum of Understanding; TZ – Tanzania;
 HIS – Health Information Systems; SIS – Health computer database in Mozambique

3.3 Methodology

This study falls under the framework of an action research paradigm, where participatory action research methodology was adopted. The empirical data were collected using various qualitative methods.

3.3.1 Participatory Action Research methodology

Action research has been typified as a way to build theory, knowledge, and practical action by engagement with the world in the context of practice itself (see, e.g. Kock 1997; Whyte *et al.* 1991). Dick (2002, p.1) explains an action research as a research approach, which has the dual aims of action and research:

- ❑ action to bring about change in some community or organisation or program;
- ❑ research to increase understanding on the part of the researcher or the client, or both.

The history of action research goes back as early as the 1940s (Baskerville 1999), when the calamities of World War II precipitated massive social changes in the research arena of the social sciences. Lewin (1947 cited Baskerville 1999) has been credited with developing the method at the Research Centre for Group Dynamics (University of Michigan) in order to study social psychology within the framework of field theory. Another group working independently at the Tavistock Clinic (later the Tavistock Institute) developed an operational research version of action research (Trist 1976 cited Baskerville and Wood-Harper 2002) to study psychological and social disorders among veterans of battlefields and prisoner-of-war camps in order to understand the complex cause of such social illnesses. Through these studies, the idea of action arose. Scientists intervened in each experimental case by changing some aspects of the patients' surrounding. This is because before World War II, these psychological syndromes had not been identified in such a large population of patients. Since the scientist and therapist were one, the scientists were participants in their own research. The effects of actions were recorded and studied. In this manner, a body of knowledge was developed about successful therapy for the illness (Baskerville and Wood-Harper 2002).

In the United States of America, the post-war funding structure of social science research did not encourage action research because it was largely sponsored by public money. Leading researchers tended to look for projects that relied on the computer analysis that attracted government attention. This led to the failure of action research to 'get off the ground' in the 1950s and 1960s (Clark 1972 cited Baskerville and Wood-Harper 2002) and a general decline in qualitative research skills. Action research methods were seldom

applied, and often of marginal scientific quality due to the discouragement of action research by the funding structure. Blum (1955) describes the marginalisation of action research as it led to the recognition that action research operated with a different epistemology than traditional science (Blum 1955 cited Baskerville 1999).

Early work by Mumford (Mumford and Weir 1979) brought the Tavistock experience into the information systems field as a systems development technique called “ETHICS”. Thirty years later, Checkland used action research in the methodology of systems development, which formed a landmark for the approach in information systems research (Checkland and Scholes 1990; Checkland and Howell 1998). Checkland used action research concept to develop soft systems methodology, by explicitly linking action research to the philosophy of science and systems science (Checkland 1981 cited Baskerville 1999). Like Mumford and Checkland, Wood-Harper (1985) also incorporated action research concepts into an action-based systems development methodology called Multiview (Wood-Harper *et al.* 1985). In the 1950s, Blum explains the essence of action research as a simple two-stage process:

First, the diagnostic stage involves a collaborative analysis of the social situation by the researcher and the subjects of the research. Hypotheses are formulated concerning the nature of the research domain. Second, the therapeutic stage involves collaborative change experiments. In this stage, changes are introduced and the effects are studied (Blum 1955 cited Baskerville and Wood-Harper 2002 p.133).

However, in order to achieve a scientific rigour, additional structure (Baskerville and Wood-Harper, 2002) is usually imposed. In the 1970s, a detailed list of phases of action research approach was mentioned to be: diagnosing, action planning, action taking, evaluating, and specifying learning, these phases are in cyclical process (Baskerville 1999; Baskerville and Wood-Harper 2002; Dick 2002; Kock 1997).

In my research, the five phase of action research approach were adopted, because Baskerville and Wood-Harper (2002, p.133) argue that, “the most prevalent description of action research details a five phase, cyclical process which can be described as an ‘ideal’ exemplar of the original formulation of action research”. This ideal approach first requires the establishment of a ‘client-system infrastructure’ or research environment.

Then, five identifiable phases are iterative: (1) diagnosis, (2) action planning, (3) action taking, (4) evaluating, and (5) specifying learning. Figure 3.2 shows this action research cycle. The key assumptions of action research are that “social settings cannot be reduced for studying and that action brings understanding” (Baskerville 1999, p.7).

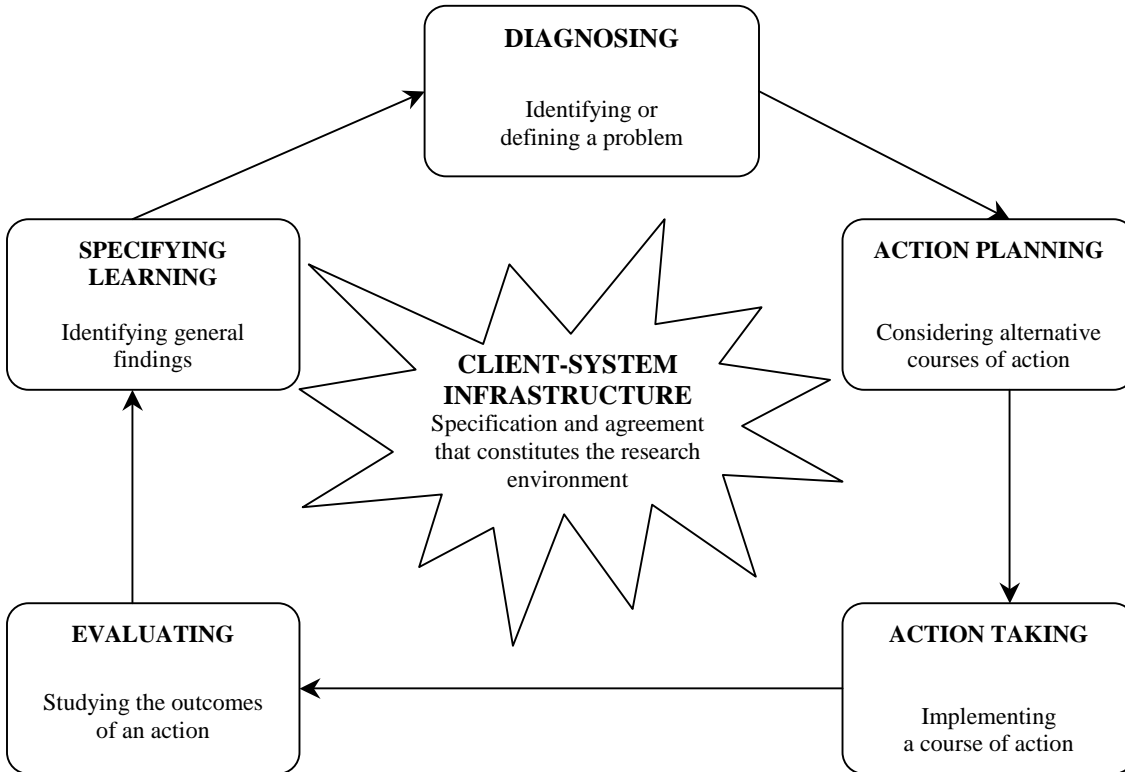

Figure 3.2: Action research cycle (Adopted from Baskerville and Wood-Harper 2002, p.134)

Client-System Infrastructure: “The client-system infrastructure is the specification and agreement that constitutes the research environment” (Baskerville and Wood-Harper 2002, p.133). Client-system infrastructure provides the authority, or sanctions, under which the researchers and host practitioners may specify actions. It also legitimates those actions with the express expectation that eventually these will prove beneficial to the client or host organization. Baskerville (1999) describes the client-system infrastructure that it may also patently recognize the latitude of the researchers to disseminate the learning that is gained in the research. A key aspect of the infrastructure is “the collaborative nature of the undertaking. The research scientists work closely with

practitioners who are located within the client-system” (Baskerville and Wood-Harper 2002 p.133).

Diagnosing: Baskerville and Wood-Harper (2002, p.134) describes diagnosing phase as it “corresponds to the identification of the primary problems that are the underlying causes of the organisation’s desire for change”. Diagnosing involves self-interpretation of the complex organisational problem to develop certain theoretical assumptions about the nature of the organisation and its problem domain.

Action Planning: After the diagnosing phase, researchers and practitioners then collaborate in the next activity, action planning. The discovery of the planned actions is guided by the theoretical framework, which indicates both some desired future state for the organisation, and the changes that would achieve such a state. The plan establishes the target for change and the approach to change.

Action Taking: This phase implements the planned action. The researchers and practitioners collaborate in the active intervention into the client organisation, causing certain changes to be made.

Evaluating: After the actions are completed, the collaborating researchers and practitioners evaluate the outcomes. Evaluation includes determining whether the theorised effects of the action were realised, and whether the effects relieved the problem. Where the change was unsuccessful, some framework for the next iteration of the action research cycle (including adjusting the hypothesis) should be established.

Specifying Learning: The knowledge gained in the action research (whether the action was successful or unsuccessful) can be directed to three audiences (Baskerville, 1999).

First, the restructuring of organisational norms to reflect the new knowledge gained by the organisation during the research, and second, where the change was unsuccessful, the additional knowledge may provide foundations for diagnosing in preparation for further action research interventions. Finally, the success or failure of the theoretical framework provides important knowledge to the scientific community for dealing with future research settings (p.14).

Action research aims to contribute both to the practical concerns of people in an immediate problematic situation and to the goals of social science through joint collaboration within a mutually acceptable ethical framework. The ideal domain of action research is therefore revealed in three distinct characteristics (Baskerville and Wood-Harper 2002 p.136) of the approach:

- ❑ The researcher is actively involved, with expected benefits for both researcher and organisation.
- ❑ The knowledge obtained could be immediately applied.
- ❑ The research is a cyclical process linking theory and practice.

3.3.2 Qualitative and Quantitative perspectives

Qualitative research avoids statistical techniques and mechanics like those made in quantitative methods. The methods used by qualitative researchers exemplify a common belief that they can provide a deeper understanding of social phenomena than would be obtained from purely quantitative data. Qualitative research is characterised by the use of the following data collection methods: interviews and questionnaires, observation and participant observation, analysis of documents, and the researcher’s impressions and reactions (Baskerville and Wood-Harper 2002; Silverman 2000). Qualitative studies generally collect data by using several methods to give a wide range of coverage (Bonoma 1985). Data collection methods are techniques, which take on specific meaning according to the methodology in which they are used. In Table 3.2, Silverman (2000, p.89) outlines different uses for four methods in qualitative and quantitative methods.

Table 3.2: Different uses for four methods in qualitative and quantitative research

Methodology		
Method	Quantitative research	Qualitative research
Observation	Preliminary work, e.g. prior to framing questionnaire	Fundamental to understanding another culture
Textual Analysis	Content analysis, that is counting in terms of researchers’ categories	Understanding participants’ categories
Interviews, surveys, and questionnaires	‘Survey research’: mainly fixed-choice questions to random samples	‘Open-ended’ questions to small samples of participants
Transcripts	Used infrequently to check the accuracy of interview records	Used to understand how participants organise their talk

Source: Silverman 2000, p.89

Silverman (2000) argues that, qualitative researchers seek to map inner experiences, language, cultural meanings, or forms of social interactions to develop deep contextual understanding of a phenomenon. Some of aims of different qualitative methods are set out in Table 3.3.

Table 3.3: Methods of Qualitative Research

Method	Features	Claim
Observation	Extended period of contact	Understanding of ‘subculture’
Texts and documents	Attention to organisation and use of such material	Understanding of language and sign systems
Interviews, surveys, and questionnaires	Relatively unstructured and ‘open-ended’	Understanding ‘experience’
Audio and video recording	Precise transcripts of naturally occurring interactions	Understanding how interaction is organised

Source: Silverman 2000, p.90

In my study, all of the data collection methods as mentioned in Table 3.3 were applied in combination. In addition to the methods mentioned in Table 3.3, the software I developed, DHIS translation and prototyping, group discussion, training workshops, and email communications are part of the methods used to collect and analyse the research data.

3.4 Data collection methods

The data collection methods deployed in this study was executed repetitively across the three different settings (application software, Tanzania case studies, and Mozambique case studies). Qualitative data collections methods were used in the semi-structured interviews, participant observations, and analysis of documents and texts. These methods were employed in analysis of the SIS computer database system; validation of the data extracted data from SIS and in studying the health data flows in Tanzania. The results of the qualitative methods were analysed using qualitative data analysis techniques (see section 3.5). Health data extracted from the SIS computer database in Mozambique and health data extracted from the district processing files in Tanzania were analysed using DHIS software by producing standard reports and calculation of indicators. Health data problems found were discussed in focus group discussions and through emails with the

HMIS officers in Tanzania and Mozambique. The following are the qualitative data collection methods used:

3.4.1 Interviews

Interview studies are used to elicit respondents' perceptions. Interviews offer researchers the chance to explore topics in depth and to gain appreciation of the context of the phenomena (Conford and Smithson 1996 cited Gallis and Kasbo 2002). Silveira (2000) argues that when conducting interviews, the researcher is responsible to think how far the respondents attach a single meaning to their responses. Questions asked during the interviews of my study were open-ended and semi-structured. This had two distinct features: first, the goal is to elicit the respondent's views and experiences in their own terms, rather than to collect data that are simply a choice among pre-established response categories; and second, the interview is not bound to a rigid interview format or set of questions.

3.4.2 Interviews of SISPROG system administrators

The SIS computer database system (SISPROG) is installed in all provincial health directorates of health (in Portuguese, Direcção Provincial de Saúde (DPS)) and at the Health Management Information System (HMIS) section of the Ministry of Health in Mozambique. The HMIS section is responsible for database configuration, fixing bugs and further development of the database system countrywide. That is to say, all DPSs are reporting their problems related to SIS at the HMIS section of the Ministry of Health.

I arranged an appointment with the HMIS section to interview the system administrators in order to get an insight on how the SIS was operating, including aspects of database structure/architecture, source codes, and general system design. At the Ministry of Health, I met two systems administrators who answered some of the questions, but they did not manage to respond to the most technical questions, instead they referred me to the most experienced system administrator who by that time was on maternity leave. I visited that experienced system administrator in her apartment where we had a two hours discussion, which was very useful for developing my understanding of the technical issues concerning the SISPROG.

3.4.3 Interviews at José Macamo General Hospital

This was my first fieldwork in Mozambique. I conducted a fieldwork attachment in order to learn how data collection, analysis and data storage take place at the health facilities. A findings report was presented at Eduardo Mondlane University, see Appendix D.1.

3.4.4 Group discussions with health statistical officer of Gaza province in Mozambique

I had visited the HMIS section of the Ministry of Health in Mozambique four times. This enabled me to perform a thorough analysis of the SISPROG. That analysis enabled me to start design and implement the extraction, transformation, and loading (ETL) software (presented in Chapter 4). The HISP team members decided to use Gaza province as our pilot site. A two weeks fieldwork was organised in April 2002 where we stayed in the field, Gaza. We rented a house at Xai-Xai beach and lived there. I used to code the ETL, go to the DPS office in Gaza to have more clarifications and come back to code the ETL system again. At the DPS, the health statistical officer was our host who instructed us how the SISPROG worked and sometimes she worked with us in our place during the night just to make sure we accomplished the task. In Photo 3.1, the left photo shows the health statistical officer (seated left with a cap), working with us in mapping health facilities at our house, during the night.



Photo 3.1: Programming ETL software (photographer: Fumo, T, Xai Xai district, 26 April 2002)

3.4.5 Interviews of health workers of Bagamoyo district in Tanzania

After the fieldwork in Mozambique, I went back to Tanzania where I conducted a two-month fieldwork from June to August 2002. The focus was on health workers at the health facilities and the District Medical Office in Bagamoyo district. However, in order to study the full flow of health data from the health facilities to the national level, the Coast Regional Medical Office (Bagamoyo district is one of the districts of Coast region) and HMIS section of the Ministry of Health were involved. I have used a questionnaire interview guide to interview health delivery practitioners, I did not hand over the questionnaire to the interviewee to complete, and instead I used it as a way to be systematic in asking questions to the informants.

The interviewed health delivery practitioners were from dispensary, health centres, hospital, regional medical office, HMIS section of the Ministry of Health, and NGOs visited when carried the research. Criteria to enrol health delivery practitioner for the interview was the physical presence of that health worker on the day of my visit. I used also participant observation techniques. I visited several health facilities in Bagamoyo district, where I conducted semi-structured interviews and observations. The interview questionnaire guide used in Tanzania is included in Appendix A. Most of the interviews and group discussion were audio taped. I found audio recording interviews to be useful, as Silverman argues that,

“certainly, depending on our memory, we can usually summarise what different people said. But it is simply impossible to remember (or even note at the time) such matters as pauses, overlaps, in-breaths and the like” (Silverman 2000, p.149).

However, while most of the informants did not care about being taped, some did and in one case study, I was not allowed to tape or to take photo.

3.4.6 Observation and participant observation in Gaza province

Observation in qualitative studies produces detailed descriptive accounts of what is going on (including verbal interaction). Silverman (2000, p. 37) argues that, “if one is really to understand a group of people, one must engage in an extended period of observation”. In Mozambique, after successfully extracting data from the SISPROG to the DHIS, the HISP team organised another fieldwork that involved installing the DHIS in some

districts and training the software using extracted data from the SISPROG as sample. That fieldwork also aimed at evaluating the extracted data, because at the district, data in copies of completed forms were compared with the data in the DHIS to see if they were the same. I also participated in training the health workers on DHIS software.

3.4.7 Analysis of documents and texts

Documents and texts is a heuristic device to identify data consisting of words and images, which have become recorded without the intervention of a researcher. In my research, these included: published research papers; conference reports; memoirs; presentation papers; and data registers. Apart from data register books and forms collected and analysed in the field, the following documents were useful source of the empirical findings of my study:

- (a) HMIS in Tanzania review report year 2000, Tanzania.
- (b) Bagamoyo district council Health Plan for the year 2002, Tanzania.
- (c) DHIS user manual.
- (d) District processing file (DPF) for Bagamoyo district medical office.

Some of completed forms and reports collected in the fieldwork were attached as appendices (see Appendix B).

3.4.8 Researcher's impressions and reactions

In qualitative research, what happens 'in the field' as you attempt to gather your data, are themselves sources of data rather than technical problems in need of solutions. For example, I was on the waiting list for three weeks to get an introduction letter to start the fieldwork in Tanzania, which demonstrated how the system works under high bureaucracy.

3.4.9 Health administrative officers interview guide contents

In my study in Tanzania, the District Medical Office, Regional Medical Office, the HMIS section of the Ministry of Health and the NGOs were categorised as organisational units carrying out the administrative tasks of the health delivery system. I assessed supervision activities, interpretation and decision-making based on the data collected and means of storage and sharing of health data. At the Regional Medical Office and Ministry of

Health, my focus was on the current computer database system, MTUHAPROG. I asked questions such as how it operates, what is good and bad about the system, and how they perceive that computer system. NGOs were also included as independent observers who could fairly judge the national health information system. The NGOs included in my study are Adult Morbidity and Mortality Project (AMMP), which deals with demographic surveillance system, and United State Agency for International Development (USAID), which is one of the donors of the Ministry of Health and deals with curative and prevention of syphilis for antenatal clients. The focus of the interviews at the NGOs was how they perceive the quality of data collected and processed at the health facilities through HMIS registers.

3.4.10 The checklists

Assessment was made through a checklist, specifically on the availability of data registers, analysis tools, and health staff employed at the health facilities and the district medical office in Tanzania. For the health staff, I made comparisons to the recommended standards by the Ministry of Health and the existing number of health staff at the health facilities I visited.

3.4.11 Prototyping the District Health Information Software (DHIS)

In Mozambique, data were extracted from SIS computer database system to the DHIS; while in Tanzania I entered data from the paper based database system of Bagamoyo district, district-processing file (DPF), to the DHIS. I used the DHIS to generate standard reports of the health data, which were discussed with the health workers at Bagamoyo district medical office and at HMIS section of the Ministry of Health in an organised one-day workshop.

Prototyping is an activity and a method within evolutionary systems development (see chapter 2 section 2.5). A memorandum of understanding (MoU) between the university of Dar es Salaam (UDSM) and University of Oslo (UIO) in collaboration with the Ministry of Health in Tanzania was established on the 5th July 2002 at the Department of Computer Science, UDSM, in order to implement the Health Information Systems Project (HISP). The MoU specifies the pilot district the HIPS project base is that I based

my study on. I installed the DHIS software at the HMIS section of the Ministry of Health and at the Bagamoyo district medical office in order to demonstrate how the DHIS software can be used in capturing and analysing health data. The MoU has served as catalyst for health practioners at the case study district (Bagamoyo) and at the Ministry of Health to feel more empowered to participate in the study, as this study was perceived as the starting point of the HISP project in Tanzania. The MoU also enabled me to get more access to health data at the district and at the Ministry of Health than before. I can then argue that, in the Tanzania setting, the MoU fulfilled the client-system infrastructure of the action research as it specify the research environment.

The prototyping of the DHIS in Tanzania involved translation of the user interface of the DHIS into Swahili. The translation was essential because Swahili is the official language in Tanzania, and some health registers at the district levels are in Swahili language (see Appendix B.3) and most of the health workers at the district are not fluent in English.

3.5 Data analysis techniques

The techniques of data analysis mentioned here are those used to analyse the data I collected in all fieldwork conducted in Mozambique and Tanzania. The purpose of data analysis is to develop an understanding or interpretation that answers the basic question of “what is going on here?” Agar (1980, p.9) describes that qualitative data collection and analysis have an inductive, cyclic character:

You learn something (“collect some data”), then you try to make sense out of it (“analysis”), then you go back and see if the interpretation makes sense in light of new experience (“collect more data”), then you refine your interpretation (“more analysis”), and so on. Thus, the process is dialectic, not linear (Agar 1980, p.9).

Data analysis was performed continuously as the study went on. For example, after the interviews at the Ministry of Health in Mozambique, I had to develop analysis in order to design the ETL software. In Tanzania, findings were presented at Bagamoyo district medical office on 27th July 2002 and at the Ministry of Health on 30th July 2002. Those presentations were then used as a point of departure in the group discussions and the email communications conducted thereafter the fieldwork.

The empirical data of this study are qualitative and quantitative in nature, and were accordingly analysed. The semi-structured interviews, observation and participant observation notices, and documents collected in the field were analysed by a qualitative content analysis (Denzin and Lincoln 1994; Downe-Wambolt 1992; Moen 2002; Morgan 1993). The health data captured in DHIS were analysed by using the DHIS software tool, and discussed with the concerned people.

3.5.1 Content analysis

I used content analysis technique, while analysing data through interviews, observations, group discussions, and workshops. Content analysis is an analytical method of coding and classifying non-numerical data. It is a suitable method for analysing verbal, visual, or written material for systematic reduction, abstraction, and simplification of recorded information, and to set off categories for developing inferences and descriptions. In the process of identifying, organising, and retrieving non-numerical data, themes emerges as categories from the data to guide further interpretation of patterns in the material (Denzin and Lincoln 1994). I transcribed the content of the audio tape-recorded information verbatim, cleaned for pauses and filled-in words, and then I checked the accuracy of the transcripts by comparing the taped interviews and the resulting transcripts. The material from field observations and group discussions, i.e., my field notes, were combined with prior analysis.

The data and materials collected from the field were analysed using content analysis methods. Data were coded and reorganised according to seven themes that emerged during the study. The themes are data generation; data management; data analysis, transmission, and reporting; data interpretation and use; feedback and supervision; training; and operation of the current computer database systems.

The background knowledge gained through the literature study guided the coding and reorganizing of the transcribed interviews to the seven themes.

3.5.2 SPSS 10.0 Statistics Package

The semi-structured questionnaire results from Tanzania fieldwork were analysed using the statistical package SPSS[®] 10.0 for Windows (Kirkpatrick 2000). The data were analysed using descriptive statistics and frequency distributions. The SPSS[®] output reports are presented in Appendix F.

3.5.3 District health information software (DHIS)

I have used the DHIS software to generate several reports in analysing the health data extracted from the computer database in Mozambique and the data I entered in the DHIS from the manual data registers in Tanzania. In making inferences about the reports produced, findings from Mozambique fieldwork was presented as a fieldwork report at the Ministry of Health on 30th April 2002. More clarifications of the interpretations of the reports generated by the DHIS were conducted through email communication with respective health officers of the HMIS in Tanzania to whom I sent the reports. Some emails for clarifications and interpretations of the reports generated by DHIS are attached in Appendix E.

3.6 Justifications of the use of participatory action research methodology

In this study, I applied an action research paradigm by using a participatory action research methodology with the use of various qualitative data collection and analysis methods. In addition to the qualitative methods, other data collection and analysis methods (like the use of photos, software development and prototyping, analyzing data using the DHIS, discussing the findings using emails) were invented and applied in the study. In choosing the methods of data collection and analysis, I put special focus on rigour: on the quality of my data and interpretation through the following guideline:

- ❑ to use brief cycles to provide adequate iterations;
- ❑ to work with multiple data sources to provide a dialectic;
- ❑ to develop interpretations as part of data collections;
- ❑ to access the relevant literature as part of interpretations; and
- ❑ to report the findings as the research goes on (see Appendix D).

The use of brief cycles resulted into difficulties in reporting/structuring the thesis. As a result I have used “Chapter” format to structure my thesis rather than the more conventional “introduction-method-results-discussion-conclusion” format. While the chapter format has allowed me to present the wide multiple data sources I accessed, its drawback was that the research findings were presented in such a way that are some how repeating in each cycle. However, since the cycles are refining the same research questions in each finding, the repetitions of the discussions of the findings is inevitable presentation, and because of the convergent nature of the process, the more detailed information presented in the later cycles supersedes the earlier information. A good example of a repeated discussion is the software developed in order to extract health data from the national computer database of the Ministry of Health in Mozambique. Also the discussion of the literature review is found in the findings in order to widen the dialectic.

The selection of the methodology to follow while executing this study was because of the roles I played in this study as a researcher and because of the nature and design of the study. This study started with fuzzy research questions but in the long run, the research questions were re-sharpened in each phase. In addition, as I was involved in HISP Tanzania and Mozambique, I had another opportunity to evaluate the progress of the HISP projects, thus I was a “researcher” who research my own practice. I played two major roles: as a researcher and as a manager. As a researcher, I applied various qualitative research methods to collect health data and analyse the empirical findings. As a manager, I managed the research processes, in each phase of the research cycle. This is to say, while conventional research methodology set the researcher to be a purely passive collector and expert interpreter of data and thus to create the notion of researcher neutrality, in this study, I was forced to take actions and manage the research processes whenever possible because of the roles I played.

Due to the nature of this study, it was very important that the research “subject” became “participants” in the research processes. For example, while prototyping the DHIS, it was important to involve users of the DHIS in the HISP pilot sites. This also stressed me to adopt participatory action research as this methodology creates partnership between

researchers and practitioners of the client system studied (the health information systems). This is because professional researchers may have expertise in how to do careful research and how to use abstract ideas; practitioners have expertise in their unique local conditions that may defy the general information of the outsider professional researcher. Bringing these two kinds of expertise together enhances the effectiveness of both.

The participation of health practitioners in the health information systems studies was fulfilled through interviews, group discussions, and training workshops. The health information systems officers at the Ministries of Health were involved through being asked permissions and introduction letters to enter the fieldwork settings, and reviewing fieldwork reports presented to them.

3.7 Chapter summary

This chapter has presented the multiple case study sites located in Tanzania and Mozambique and the timeframe of the research from March 2002 to October 2002. The chapter has also described the theory about action research methodology, and the data collection and analysis methods employed in this study.

CHAPTER 4

APPLICATION SOFTWARE AND DISCUSSION

Wilson (2000, p.199) suggests that, “the creative use of microcomputer technology is one of the most promising means of improving the quality, timeliness, clarity, presentation, and use of relevant information for primary health care management”.

In this chapter, I present discussions of efforts made to implement computer system in the health sector in Tanzania and Mozambique. Four software systems are presented, SISPROG (the national computer database of the Ministry of Health in Mozambique), DHIS (a computer software from HISP Project), dBase Filter (an application software developed in this study), and MTUHAPROG (the national computer database of the Ministry of Health in Tanzania).

4.1 The computer database of the Ministry of Health in Mozambique

4.1.1 General features

The purpose of the national computer database system SISPROG is to computerise the important routine health data reported by the health facilities at the province and national levels in order to be managed, monitored, and analysed.

The history of SISPROG goes back to 1994, which was developed and deployed in 1992 - 1994 in Mozambique by an expatriate expert who left the country before the system was complete. SISPROG was expected to capture data from ten health data reports from the districts level, however only four were computerised fully. After the expert left the country, no one was able to continue to program and complete the remaining modules. SISPROG has been in operation since 1994 and therefore that computer database has historical data reported for a decade until at the time of writing. The data in SISPROG were captured through the following data reporting instruments:

- ❑ Form A04. Records immunization data reported per district and monthly
- ❑ Form B06. Records children consultancies reported per health unit monthly
- ❑ Form B07. Records maternity and deliveries reported per health unit monthly
- ❑ Form B08. Records pregnant consultancies reported per health unit monthly

4.1.2 SISPROG hardware and software requirements

The program is running on Microsoft disk operating system (MS DOS). SISPROG was developed in dBase III, a relational database management system (DBMS) for Windows 95, and does not support the use of a computer mouse.

4.1.3 SISPROG system design and implementation

In this study, the only SISPROG documentation found is the user guide, which was developed in 1994. The source codes, system design, and installation disks were not accessed. However, through interviews and observations, I learned that the source codes and system installation files of the SISPROG had crashed with an old TOSHIBA laptop, leaving the administrator with the source codes of the installation files.

However, I analysed the system intuitively and managed to break the codes. SISPROG was designed and implemented as follows:

- ❑ All health data element like “BCG first dose, OPD attendance” were hard coded, i.e., if you want to modify the data element name, or you want to change/add data element then you must change the source codes.
- ❑ The data elements and names of the facilities were registered in a short format. For example, while ‘Form A04’ has ‘BCG - 0-11 meses’ data element, SISPROG had ‘BCG1’ data field that corresponds to that field of the paper form.
- ❑ SIS stores ‘date’ in two fields. For example, to store the date, ‘June 2002’, SISPROG stores ‘6’ and ‘2002’ in two columns.
- ❑ SIS put zero ‘0’ as a default value, i.e., if a value of a data element is not available, SISPROG will automatically insert zero.

4.2 DHIS software: Health data analysis tool

4.2.1 General features

The latest version of the DHIS software was developed in Microsoft Access 2000 platform. This is an open-source software where clients receive the software and its source codes. Since the software is shipped with its source codes, clients have the authority to make changes by reprogramming the software if they can, however, with

open-source license, users of DHIS can confront any one in the open-source community including the vendor of the DHIS software to fix up bugs that arise in the long run of the software. In Mozambique, DHIS comes with the HISP project, thus the HISP team members coordinate all general and technical maintenance and sustainability of the DHIS software, including translating the software into Portuguese.

DHIS was designed to capture routine and semi-permanent health data. Routine health data includes the data generated in the health facilities, when health practioners perform their routine health delivery tasks. Semi-permanent data usually consist of data for administrative and monitoring purposes, like number of staff in a health facility, total population, etc.

4.2.2 DHIS hardware and software requirements

Minimum Hardware Requirements

DHIS will run on any PC that can run Access 97, like 16 MB of memory (RAM), and around 200 MB of free hard disk space is the absolute minimum.

Operative System Requirements

The DHIS software runs on all Windows platforms, except Windows 95A (also called OSR-1) and NT 3.5x.

4.2.3 DHIS system design and implementation analysis

DHIS design and implementation features that relate to that of SISPROG described above are as follows:

- The health data elements are stored as records of the database. That is to say, if one wants to edit/add/delete any data element, they can do so without accessing or changing the source codes of the system.
- The data elements in the DHIS are stored in long full names as they appear in their corresponding paper forms and register books. For example, while 'Form A04' has 'BCG - 0-11 meses' data element, DHIS also has 'BCG - 0-11 meses' data field.

- In DHIS, the date is stored in “date” data type. For example, to store June 2002, DHIS will store “June 2002” in one column (data field).
- DHIS puts nothing (null) for a missing data entry value.

4.3 Database Filter: extraction, transformation, and loading (ETL) software

Database Filter application software is the software I developed in order to accomplish a task of extracting health data from SISPROG to the DHIS. The software was aimed at integrating the technical design and implementation differences of SISPROG and DHIS, so that the two systems can communicate their data.

4.3.1 System analysis and design

To extract data from one computer database to another, you need to know, what is exactly to be extracted from the source database system. Health facilities have a defined list of health data elements that health workers record their instances. For example, number of deliveries per month, number of out patients visited the health facility per month, etc. Thus, these data elements are constant values; the health data is the count (data entries) of occurrences of these health data elements. A complete routine services reporting record could be “February 2003, rural hospital Chicumbane, number of deliveries is 39”. This record has four main parts: period, place, data element name, and data entry value. Period is ‘February 2003’, place is ‘rural hospital Chicumbane’, data element is ‘number of deliveries’, and the data entry is ‘39’.

Data element name, health facility/organization units (place), and period are pre-defined values, thus, they exist in both databases, SISPROG and DHIS. To extract health data from one database to another we need to transfer the “data entry” values from the source database to the target database. To do so, we need to map the three parameters: “place” where the data was recorded, “period” when the data was recorded, and “name” of the data element and the health facility from the source database to that of the target database. After mapping those three parameters, the next step is to copy the data entry values from the source database to the target database.

DHIS accepts data file that has certain data field header labels; the data field should be separated (delimited) in certain format and the file should have a fixed number of data field columns. The following is the header line of an import file for the DHIS database:

"strDataField","strOrgUnit","Period","dblEntry","strComment","intMin","intMax","ysnDisplay","strUser","dtmChanged" (analysis of the DHIS Export file, April 2002).

Below is an example of a record of an import text file of the DHIS:

"Consultas seguintes 0-11 meses","Centro de Saúde de Alto Changane",2000/01/01 00:00:00,0.00, "from DHIS",0.00,0.00,1,"Lungo",2002/01/26 00:00:00 (analysis of the DHIS Export file, April 2002).

The challenge was that the source database has no function that exports data into a text file that has column headers, number of columns and delimited as that of DHIS import file. In addition, although the data elements in the SISPROG database and that of DHIS are semantically the same, the two databases records these data elements in different formats.

Major discrepancies between SISPROG and DHIS

Date formats

SISPROG database stores date into two data fields in number format while the DHIS stores date filed in one column and in the date format. For example, SISPROG has “ANO (year)” column and “MES (month)” column, e.g. February 2000 is stored as follows:

ANO	MES
2000	02

While the DHIS stores the same date as follows:

Period
February 2000

Naming of data element system

SISPROG uses short name of health facilities, like “cs Alto Changane”, while the DHIS uses long name like “Centro de Saúde de Alto Changane”. The SIS database uses

abbreviation symbols to record the data field (data elements), while the DHIS uses full name, see Table 4.1.

Table 4.1: Names of health data elements in SISPROG and DHIS

ID	SISPROG Data Field	Related Paper Form	DHIS Data Field
8	CCM	B06	No Mau Crescimento 0-35 meses
9	CP1	B08	1as Consultas Pré-natais

Source: Comparative analysis of SISPROG, DHIS, and SIS paper forms

Different data field values that represent the same thing

The DHIS records the **name** of the health unit, while SISPROG records the **code** of the health unit. In addition, DHIS records more details of the health unit than those given in the SISPROG.

Table 4.2: Data fields and names of health facilities in the DHIS

strDataField	strOrgUnit	dblEntry
1as Consultas 0-11 meses	Centro de Saúde de Alto Changane	247
1as Consultas 0-11 meses	Centro de Saúde de Alto Changane	290
Consultas seguintes 0-11 meses	Centro de Saúde de Alto Changane	65

Source: Analysis of the DHIS export file, April 2002

Table 4.3: Data fields and codes of health facilities in the SISPROG

DCOD	UCOD	CP1
10	01	1248
10	02	695
10	16	583
10	08	286
10	10	159

Source: Analysis of SISPROG data files, April 2002

Where, ‘DCOD’ is the district code, ‘UCOD’ is the health unit code and ‘CP1’ is the name of the health data element called “1as Consultas 0-11 meses”. The default value for SISPROG is ‘zero’, while that of DHIS is ‘null’. The unit of analysis of SISPROG is the provincial level, while the unit of analysis of the DHIS is at district level. The difference

is that with SISPROG, data are recorded by district, while in DHIS data are recorded by health facility.

4.3.2 Database Filter system architecture

The ETL software is built on homogenous architecture, as it involves only a single source system and a single target system. Data flows from the single source of data through the ETL processes and is loaded into the target system, as shown in the Figure 4.1.

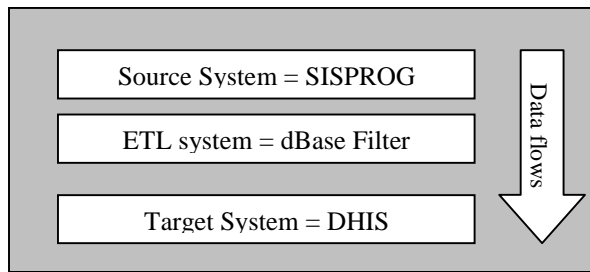

Figure 4.1: Database Filter system architecture

4.3.4 System Implementation

How the ETL system works

The ETL system connects the two databases using connection "bridges", and maps from the database to the ETL system. This enables the ETL to copy the data from the source database (SISPROG) to its temporary data files, and transforms the data into a format that the target database (DHIS) understands. To load the data to the DHIS, the ETL system creates texts and Microsoft Excel files. The DHIS imports the data to the DHIS database.

The ETL system consists of four distinct functional elements: data to the DHIS, the ETL system creates texts and Microsoft Excel files. The DHIS imports the data to the DHIS database. Figure 4.2 presents how the ETL system integrates the DHIS and the SISPROG databases.

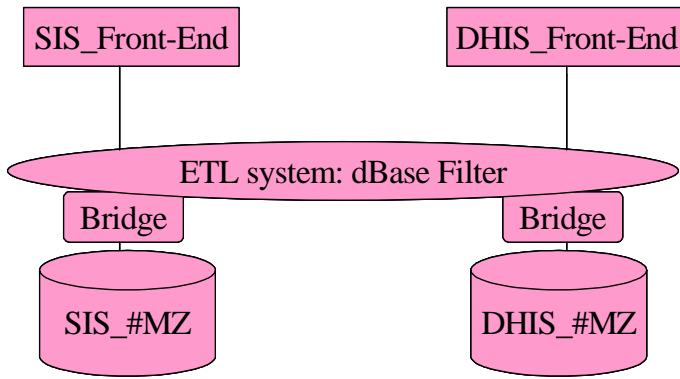

Figure 4.2: SISPROG and DHIS integrated by Database Filter ETL system

This ETL system consists of four distinct functional elements:

- Extraction
- Transformation
- Loading
- Meta data

Extraction

The extraction element is responsible for extracting data from the source system. This ETL software connects to the SISPROG and DHIS databases at the same time, then copies the data, leaving the original data in place. Figure 4.3 shows the connection screen. The files with 'dB' prefixes are from SIS and the other two files are from DHIS.

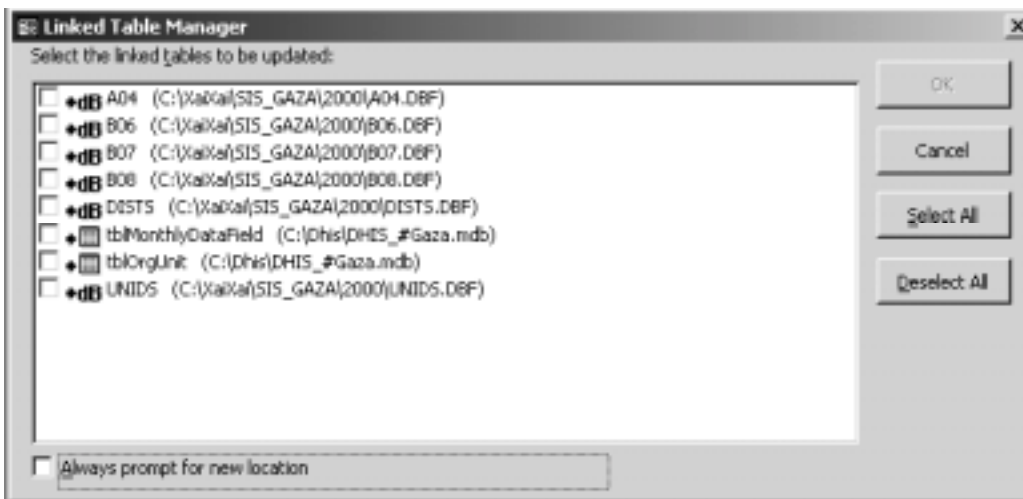

Figure 4.3: Database Filter connected to the SISPROG and DHIS databases

After connecting to the SIS database and the DHIS, the program presents screens that allow users to map health units and health data elements from that of SISPROG to DHIS. Figure 4.4 presents the health facilities records from SIS and DHIS, so that users can map the matching records, and Figure 4.5 presents health data elements from SISPROG and DHIS, so that users can match the two lists.

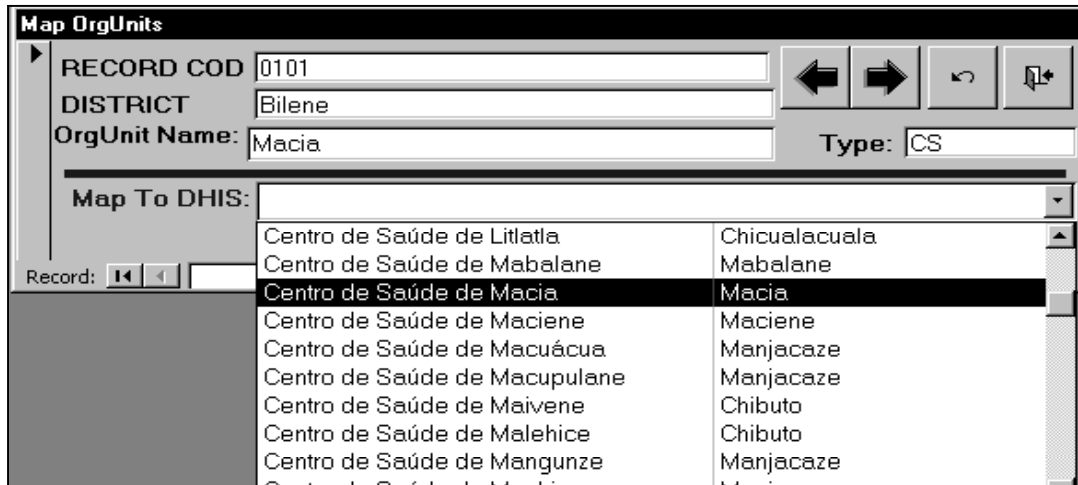

Figure 4.4: Mapping health facilities from SISPROG to DHIS

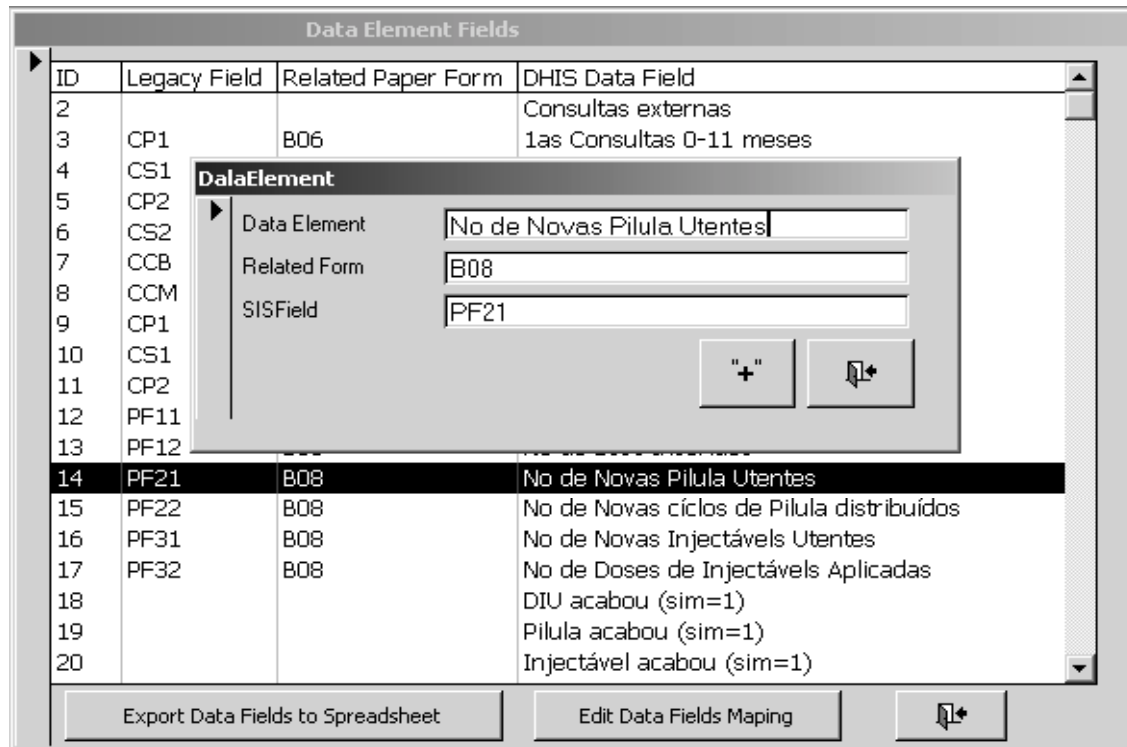

Figure 4.5: Mapping data elements from SISPROG to DHIS

When the mapping of data elements is ready, the next step is to load the data in temporary data files using a command menu “Update Data File” (see Figure 4.6). The subsequent commands in Figure 4.6 have the following functions:

- ❑ Select Data Field – allow the user to select the data elements to extract data
- ❑ Create DHIS File – this command performs the transformation functional element of the ETL system.

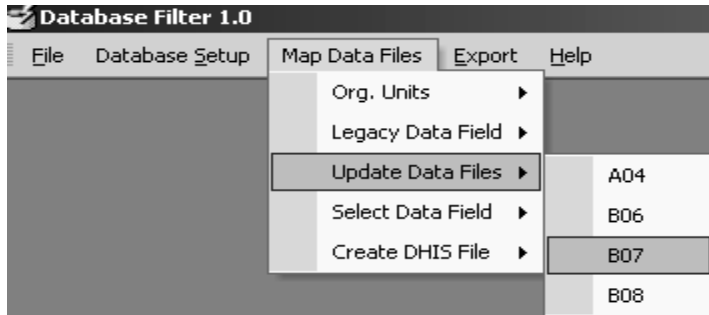

Figure 4.6: Extracting data modules

Transformation

The major tasks performed here are data validation, data accuracy, data-type conversion, and business rule application.

Data validation: This is important to enforce data integrity. Table 4.4 presents the DHIS import file headings. Since SISPROG has no data entries for every column, default values were added to the columns that cannot receive data from the source database.

Table 4.4: DHIS Import file headers

strDataField	strOrgUnit	Period	dblEntry	strComment	intMin	intMax	ysnDisplay	strUser	dtmChanged
--------------	------------	--------	----------	------------	--------	--------	------------	---------	------------

Data accuracy: To ensure that Boolean data fields contain appropriate values, “YES or 0” values from SIS are converted to “TRUE” and “NO or 1” values from SIS are converted to “FALSE” in the ‘ysnDisplay’ column of Table 4.4.

Data type conversion: This is to ensure that all values for a specified field are stored in the same way in the target system (DHIS) regardless of how they were stored in the source system (SISPROG). Thus, the major task here is to convert the “dates” and ‘names’ data types used in SIS to conform to the DHIS data types. Figure 4.7 shows how SIS date format was converted into DHIS date format.

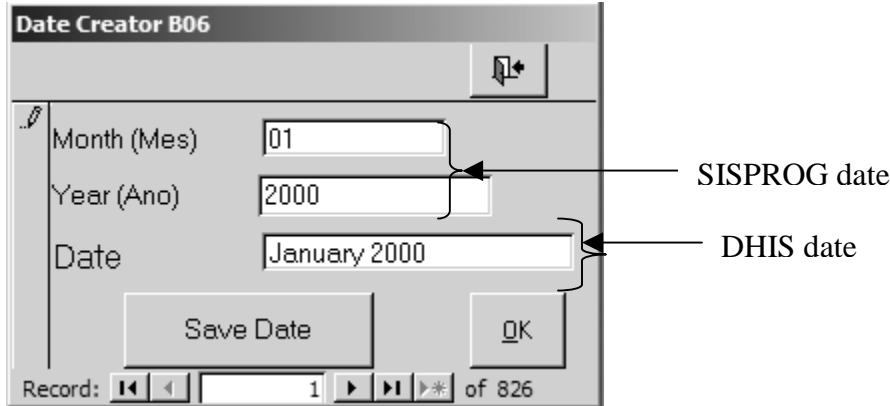

Figure 4.7: Date creator

Business rule application: The default values for SISPROG is ‘zero’ while that of DHIS is ‘null’. However, the business rule in HMIS is that a health unit can report ‘zero’ occurrence of health data element in a certain period. Since SISPROG has zero as its default values. This is contradicting in that, either the health unit did not report or it has reported zero values. However, for my interest, the SISPROG data will be imported as they are, that will help in assessing the quality of the data. Figure 4.8 presents extracted and transformed SISPROG data in the Database Filter ETL software system.

Database Filter 1.0 - [Export_MDData : Select Query]				
File Database Setup Map Data Files Export Help				
	strDataField	strOrgUnit	Period	dbEntry strComm
▶	Consultas seguites 0-11 meses	Centro de Saúde de Alto Changane	January 2000	0 from SIS
	1as Consultas 0-11 meses	Centro de Saúde de Alto Changane	January 2000	247 from SIS
	Consultas seguites 0-11 meses	Centro de Saúde de Alto Changane	February 2000	0 from SIS
	1as Consultas 0-11 meses	Centro de Saúde de Alto Changane	February 2000	290 from SIS
	Consultas seguites 0-11 meses	Centro de Saúde de Alto Changane	March 2000	65 from SIS
	1as Consultas 0-11 meses	Centro de Saúde de Alto Changane	March 2000	61 from SIS
	Consultas seguites 0-11 meses	Centro de Saúde de Alto Changane	May 2000	190 from SIS
	1as Consultas 0-11 meses	Centro de Saúde de Alto Changane	May 2000	114 from SIS
	Consultas seguites 0-11 meses	Centro de Saúde de Alto Changane	June 2000	144 from SIS
	1as Consultas 0-11 meses	Centro de Saúde de Alto Changane	June 2000	48 from SIS
	Consultas seguites 0-11 meses	Centro de Saúde de Alto Changane	July 2000	143 from SIS
	1as Consultas 0-11 meses	Centro de Saúde de Alto Changane	July 2000	46 from SIS
	Consultas seguites 0-11 meses	Centro de Saúde de Alto Changane	August 2000	105 from SIS
	Consultas seguites 0-11 meses	Centro de Saúde de Alto Changane	August 2000	253 from SIS
	Consultas seguites 0-11 meses	Centro de Saúde de Alto Changane	September 2000	187 from SIS
	1as Consultas 0-11 meses	Centro de Saúde de Alto Changane	September 2000	68 from SIS
	1as Consultas 0-11 meses	Centro de Saúde de Alto Changane	October 2000	92 from SIS
	Consultas seguites 0-11 meses	Centro de Saúde de Alto Changane	October 2000	148 from SIS
	1as Consultas 0-11 meses	Centro de Saúde de Alto Changane	December 2000	96 from SIS
	Consultas seguites 0-11 meses	Centro de Saúde de Alto Changane	December 2000	145 from SIS
	1as Consultas 0-11 meses	Centro de Saúde de Barragem	January 2000	477 from SIS
	Consultas seguites 0-11 meses	Centro de Saúde de Barragem	January 2000	0 from SIS
	1as Consultas 0-11 meses	Centro de Saúde de Barragem	May 2000	146 from SIS
	Consultas seguites 0-11 meses	Centro de Saúde de Barragem	May 2000	106 from SIS
	Consultas seguites 0-11 meses	Centro de Saúde de Barragem	June 2000	232 from SIS
	1as Consultas 0-11 meses	Centro de Saúde de Barragem	June 2000	107 from SIS
	1as Consultas 0-11 meses	Centro de Saúde de Barragem	July 2000	42 from SIS
	Consultas seguites 0-11 meses	Centro de Saúde de Barragem	July 2000	112 from SIS
	Consultas seguites 0-11 meses	Centro de Saúde de Barragem	August 2000	222 from SIS
	1as Consultas 0-11 meses	Centro de Saúde de Barragem	August 2000	74 from SIS

Figure 4.8: Data extracted from SIS previewed on the ETL software

Loading data

Extracted and transformed data is saved in a text file formatted as a DHIS import file. This resulting text file then is loaded into the DHIS using the import module of the DHIS software. Figure 4.9 displays commands that users can choose to export the data extracted from SISPROG. The data extracted can also be exported to Microsoft Excel file, however the DHIS can only accept data formatted in 'text file'.

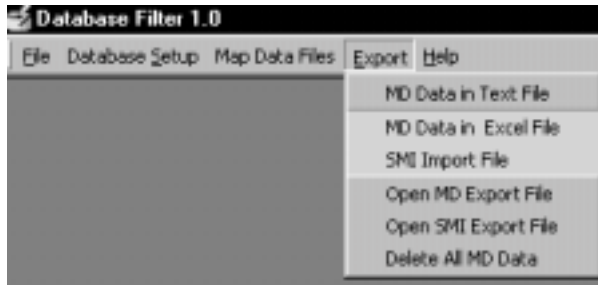

Figure 4.9: ETL software export commands

Meta data

The ETL system meta data functional element is responsible for maintaining information (meta data) about the transformation of data and documents the data mapping used during the transformation. This allows users to save their data elements and health units mapping, so that they can retrieve the mapping, instead of mapping it again in the future. For example, if one maps all health units from Gaza province, then Inhambane province, it is possible to see the mapping of Gaza again.

4.3.5 System development approach

Evolutionary development approach was adopted in the development of the ETL system. Evolution development is based on the idea of “developing an initial system, exposing this to user comments, and refining this through many versions until an adequate system has been developed” (Sommerville 2001, p.46). The context of developing the system has forced me to adopt an evolutionary approach. First the source system has no documentation, no source codes and the user manual is in Portuguese, a language I do not speak. In addition, this software is a small program (less than 100,000 lines of codes). Therefore, rather than having separate system specification, development and validation activities, I carried out these activities concurrently and the specification of the system was developed incrementally.

4.3.6 Hardware and software requirements for running the program

This program (Database Filter 1.0) runs on any PC that can run Access 97: 16 MB of memory (RAM) and around 10 MB of free hard disk space is the absolute minimum.

Operative system requirements

The program runs on all Windows platforms except Windows 95A and NT 3.5x. The Database Filter 1.0 is currently not available for **Linux/Unix** systems.

4.3.7 Limitation of the Software

As shown in the design phase of this program, this is a specific software for extracting data from the SISPROG database in Mozambique to the DHIS. Some labels of the user interface (screens) are in Portuguese, and some features of transforming the data is exclusively depend on one feature of the source database. For example the conversion of the SIS date format to the DHIS date format, not all legacy information system store date in integer data type.

4.3.8 Demonstration of the data extracted from SISPROG using the ETL system

After successful migration of the health data to the DHIS, the HISP team installed the DHIS in other districts of Gaza province in order to verify the correctness of the data extracted and to train DHIS users using the extracted as sample data. Thus, the data in the DHIS was compared to the data in the completed forms to see if are the same figures. The extracted data from SIS database were compared to that in the completed paper forms in three districts: Bilene, Chibuto and Mandlakaze in Gaza province and proved to be the same data reported by the respective districts. Any mismatch between the data in the paper form and the data in DHIS extracted from SISPROG was a result of incorrect values entered in SISPROG.

4.3.9 Alternative ETL solutions

There were other efforts to extract data from the same database (SISPROG). A colleague of mine from Oslo also worked on developing a system that extracted data from SISPROG to the DHIS but on different platform from that of mine. While my application software is developed on Microsoft Visual Basic 9.0 for Access, he developed his ETL system tool on Java platform. The similarity of our applications is that we extracted the same SISPROG data from the same data files and all the applications create text files that can be imported to the DHIS. That is to say, the loading functionalities of our ETLs were the same DHIS import module.

An experienced systems analyst from South Africa who is the pioneer of developing the DHIS developed another solution. That experienced systems analyst studied the data extracted from SISPROG to the DHIS using the two ETLs mentioned above and determined that the two ETLs did not give users an option of cleaning the data. However, some of the data from SISPROG needed to be cleaned before being imported to the DHIS. The solution from South Africa gave the possibility to users to perform data cleaning manually. For example, the DHIS did not allow zero count of data elements entry values but SIS has default value zero. This means that, data extracted and imported from SISPROG as they are may have some zero data entry, but when cleaned will not. While the data cleaning seems to be an additional work when one extract data from SISPROG, it promises to give a good result of higher quality data.

The solution from South Africa demonstrates another cycle of the action research where the results of the first action was assessed, analysed, and refined again by another action phase.

4.4 The computer database of the Ministry of Health in Tanzania:

4.4.1 General features

As in the HIS in Mozambique, the HMIS in Tanzania also has a computer database system installed in all regional medical offices and at the HMIS section of the Ministry of Health. The HMIS in Tanzania is known in its acronym MTUHA, and the computer database is referred to as MTUHAPROG. A local software company in Tanzania has developed MTUHAPROG, a donor funded project. The approach of the donor to pay for the software directly to the local company had implications that the users of the software, the Ministry of Health, had little say in the development. Thus, there was limited participation of the users and by that time, the company already had the money. Nevertheless, the vendor delivered the software, developed on Microsoft Access 97, in 2000. Before this, the Ministry of Health in Tanzania had a computer database developed in dBase IV. However, because of time constraints, that legacy database of HMIS in Tanzania was not covered in this study.

Data for the regional and national computer database come from the following reports:

- ❑ Annual Health Facility Report (F005);
- ❑ District Staff list (D001);
- ❑ District Quarterly Report (D004); and
- ❑ District Annual Report (D005).

4.4.2 Hardware and software requirements

MTUHAPROG runs on any PC that can run Access 97: 16 MB of memory (RAM) and around 200 MB of free hard disk space is the absolute minimum. MTUHA software runs on all Windows platforms and has windows user interface.

4.4.3 System design and Implementation analysis

I did not perform a detailed analysis of MTUHA database design and implementation. However, I inspected MTUHA database to see if has the same features like that of SISPROG. In doing that analysis, the following features were determined:

- ❑ Data elements were hard coded.
- ❑ Incomplete implementations. Some reports and forms were not working.
- ❑ No access to the source codes. The vendor owns the source code, so if the Ministry of Health want to fix bugs or add a new feature, they have to undergo contractual negotiations with the vendor. If the Ministry has no money, no bug will be fixed.

A more detailed discussion of the features of MTUHAPROG that imposes problem in the HMIS in Tanzania is presented in Chapter 7.

4.5 Chapter summary

This chapter has presented four application software: SISPROG, DHIS, Database Filter, and MTUHAPROG. SISPROG is the national computer database of the health management information system in Mozambique. DHIS is a health data analysis tool that comes with HISP project and is being piloted in three provinces in Mozambique, “Database Filter” is an ETL application software developed by me, in order to populate the DHIS with health data from SISPROG, and MTUHAPROG is the computer database of the HMIS in Tanzania. The effort of migrating data from SISPROG to DHIS not only

served for populating the DHIS with health data but was also an effort to work around the problems imposed by the inflexibility of the SISPROG. The relationship between the software development and the action research cycles is demonstrated as in Figure 4.10.

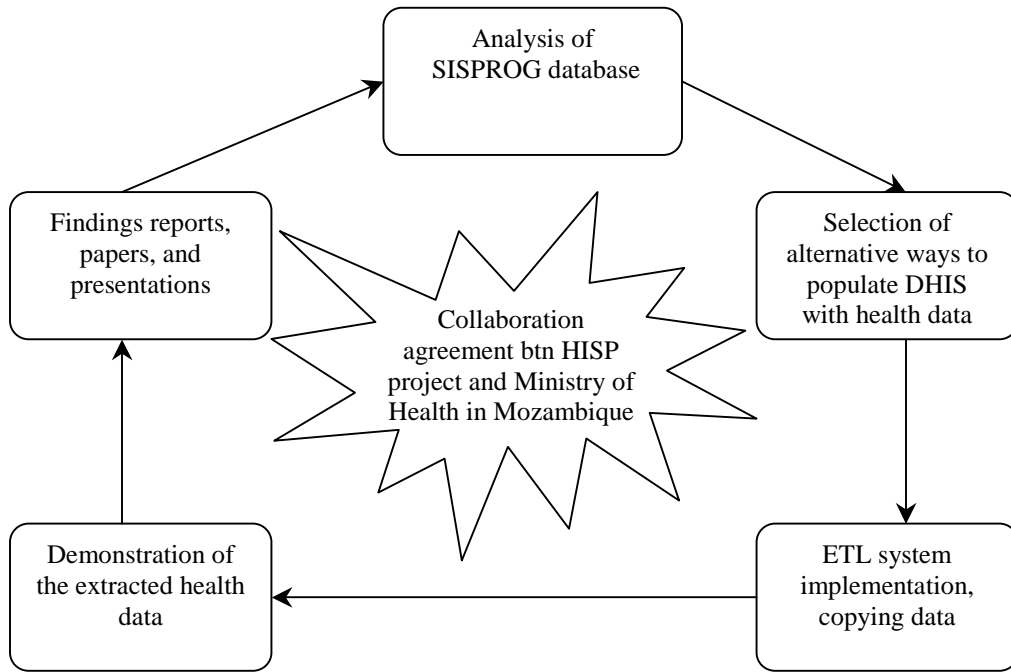

Figure 4.10: phases of action research cycle in Mozambique

CHAPTER 5

CASE STUDIES IN MOZAMBIQUE AND DISCUSSION

This chapter presents the assessment, analysis, and actions taken in the Mozambique case studies. The situational analysis of the health information system in Mozambique, and the progress of the HISP project in Mozambique are presented in separate subsections. The chapter is structured in the following order: section 5.1 presents diagnosis phase of populating the DHIS with health data, section 5.2 presents the action planning phase of the diagnosis made in section 5.1, and section 5.3, is a description of the action taken after the analysis phase in section 5.2. Section 5.4, is a situational analysis of the health information system and evaluation of the outcomes of the action, which documents some of the problems of the existing health information system, and Section 5.5, is an assessment of the progress of HISP project in Mozambique.

5.1 Diagnosis phase

HISP has been in Mozambique since 1999. Key committee members of HISP project in Mozambique developed the theoretical assumption that if all historical health data locked on the SISPROG could be extracted and loaded to the DHIS, the Ministry of Health will use the DHIS as National Computer Database System. In Mozambique, there were already three HISP pilot districts: Chokwe districts in Gaza province, Maxixe district in Inhambane province, and Cuamba district in Niassa province. Based on that assumption, there was the need to populate the DHIS with health data. To do that, there were two options: (1) to collect the completed paper forms and enter all the data to the DHIS and (2) to extract the health data already saved in the current database (SISPROG) to the DHIS.

5.2 Action planning

Option (1) of section 5.1 above, to collect the completed paper forms and enter all the data to the DHIS, seemed to be unfeasible solution because there were many completed forms that were already misplaced. The loss of many data sources is due to many reasons,

including natural calamities such as the flood of Limpopo River in the year 2000, which resulted in the destruction of all documents at the Chokwe district health office and district rural hospital (the hospital was under water). Therefore, the HISP team members and I agreed that extracting data from SISPROG to DHIS was the feasible solution. We further agreed to work on data stored at Gaza province, because the province is nearby Maputo and the SISPROG system has enough data from 1994 to 2002.

In this action planning phase, we were seeking to meet the desired future state of populating the DHIS with SIS data from Gaza as starting point and running the DHIS in all districts in Gaza province where there are supporting infrastructures like computers and electricity. The change was to replace SISPROG with the DHIS and some practice of collecting data. The approach to implement these changes was to extract data from SISPROG to DHIS, and conduct demonstrations and training health workers on how they can use DHIS as health data analysis tool.

5.3 Action taking: extracting data from SISPROG

The third phase “action taking” is characterised by the process of migrating health data from SISPROG to DHIS. In that phase, I developed an extraction, transformation, and loading (ETL) software tool that managed to extract data from SISPROG to DHIS (see Chapter 4 section 4.3). The source database system was built in dBase III and was developed in 1994. The target database is a Microsoft Access 2000 database. The extraction, transformation, and loading (ETL) software tool developed is called “Database Filter”.

5.3.1 Collaboration and Learning SIS computer database at Gaza

Photo 5.1 below shows the building of the Direcção Provincial de Saúde (DPS) de Gaza (in English, Gaza Provincial Directorate of Health). I have been there at three different times: first, I went there to be introduced how the current computer database system works. HISP members in Mozambique, my fellow researchers, and my research supervisor were introduced on how the SISPROG operates by the provincial health

statistical officer who was the responsible person for SISPROG. We attended that session for three days consecutively, before I copied the SISPROG database and installed it in my computer, where I started to develop the ETL software in the field setting.



Photo 5.1: Learning SIS database system at Gaza province

Second, I went there to attend a meeting with the Provincial Health Director. The purpose of the meeting was to give us a welcome at the province and to say that he is backing our efforts of introducing a new system for data collection and analysis.



Photo 5.2: Participation of the provincial health officers (photographer: Lungo, J.H., Gaza, 22 April 2002)

While working on the ETL software, I worked side by side with the Health Statistical Officer, who guided the process of editing the list of health facilities and selecting the data files of the SISPROG that has valuable data to extract. Lastly, a HISP team member and I went there to copy the DHIS database populated with health data to their computer which runs the DHIS, and to demonstrate several DHIS reports with the extracted data.

5.4 Evaluation of the performance of the ETL system

After successful migration of the health data to the DHIS, the HISP team installed the DHIS in other districts of Gaza province. The data in the DHIS were compared to the data in the completed forms at the districts and compared to the data in SISPROG for verifications purposes. The extracted data from SISPROG were compared to the data in the completed forms in three districts: Bilene, Chibuto, and Mandlakaze in Gaza province and proved to be the same data reported by the respective districts. Any discrepancy between the extracted data from SISPROG and the data in paper forms was attributed to errors occurred while entering the data in SISPROG but not because of migrating the data to the DHIS.

We (HISP team members and I) produced a group report of our fieldwork and we made two presentations at the Ministry of Health in Mozambique. That characterised the fourth phase ‘evaluation’ of my action research cycle. The outcome of the action taking, is the development of the software that extracted data from the SISPROG to the DHIS, data were migrated successfully. The evaluation as to whether this effect has relieved the problem can be answered to “yes” and “no”; yes in the sense that all data from SISPROG can be moved to the DHIS and thus technically SISPROG, could be replaced with DHIS. However, it seems that, important business rules may be embedded in the software (Sommerville 2001), and are not documented elsewhere. The SISPROG is still running even at the HISP pilot districts where DHIS was tested and proved to perform better. Users have been reluctant to start using the DHIS, pointing out that they are still waiting for an order from the higher authority that they should officially use the DHIS.

The subsequent activities of the research were to expand the ETL software tool to reach more data that are diverse. The SISPROG files that have health data are 'A04', 'B06', 'B07', and 'B08'. These files have data since 1994 but in the first iteration in the action research cycle, only data from SISPROG data file 'B06', 'B07' and 'B08' of the year 2000 were extracted. In the next iterations, data from SIS data file 'A04' were included and all data from 1999 to April 2002 were migrated to the DHIS.

5.4.2 Research case study sites from Gaza province

Manjacaze district health directorate and district rural hospital

This is a remotely located district of Gaza province. I visited the district directorate after extracting the data from the SISPROG to the DHIS. Since the district office has a computer, we went there to install the DHIS with data so that they can crosscheck the data with those on the completed forms. On that day, it happened that there was a district workshop for demonstrating analysis of data. We attended the meeting and I benefited in that I learned how they analyse the data, especially the drawing of graphs. We visited the rural hospital, where I also found a new story, which made me work hard on my research and have the feeling that what I am doing is to serve my people.

In the hospital, we found a dying child who needed an urgent blood transfusion. The director of the hospital told the mother of the child that the hospital was running out of bloodstock, and there were no volunteers to donate blood. One of my colleagues volunteered to donate blood but, unfortunately, her blood group did not match with that of the dying child. Next step is to ask the hospital director to refer the child to another hospital. Although the hospital did not have a car, we agreed to use our car to transfer the child immediately. While we were pressurising the hospital director to give the child a referral letter, a big bottle full of blood was retrieved from nowhere, blood transfusion was set for the child. One of my colleagues drove there next day and found the child was discharged, walked home energetically.



Photo 5.3: Manjacaze district directorate of health and rural hospital (photographer: Lungo, J.H., Manjacaze district, 06 May 2002)

The sad story suggests that there is a need of developing a working health information system. If the information system had been working properly, one could have traced the cause of death and the availability of drugs. In this case, if it was possible to trace that the child died because of shortage of blood, while the blood was there, I believe no one could have cheated that there is no bloodstock. However, since there is no one to trace the case or it is impossible to trace the case because of poor information reported, or no use of the information, then there is no accountability.

Chibuto district health directorate and rural hospital

I visited that health facility together with other medical students from the Faculty of Medicine, Eduardo Mondlane University. Those students were learning how to analyse health data, so they went there to collect data from the completed files and enter the data in the DHIS. My task was to install and configure the DHIS loaded with health data extracted from SISPROG so that they could learn how to create complete records and manipulate those records before starting to create their own records.



PhD student (in front) teaching DHIS at Chibuto district health directorate

Meeting of Chibuto district health director (left)

Photo 5.4: Chibuto district health directorate and rural hospital (photographer: Lungo, J.H., Chibuto district, 06 May 2002)

Posto de Saúde Julius Nyerere

This is a typical village health post named after the first president of Tanzania. The idea of visiting the health post was to learn data collection at the health facilities. On the day of my visit, the health post had two clinicians, one messenger officially employed, and three volunteers. There were a large number of patients. Problems related to collection of information were pointed out that they felt overworked because of the time taken to fill the forms.

Bilene district health directorate and rural hospital

This rural hospital and district medical office is located 50 metres from the main road. There are three working computers with the DHIS installed. I visited Bilene directorate of health two times. In the first trip, I went there to copy their data extracted from SISPROG to DHIS on their computers, and on the second visit, I went there with a HISP team member for training the health workers to use the DHIS.



Photo 5.5: Bilene district health directorate and rural hospital (photographer: Lungo, J.H., Bilene district, 25 April 2002)

Núcleo de Formação Contínua de Chicumbane

This information unit has installed computers and it is where the DHIS is working in Xai-Xai district, apart from the Provincial health office. I have been there first for the DHIS training session. Then I went back three months later to participate in a training workshop that involved all health officers and district medical officers from the province of Gaza on the capture and analysis of data using the DHIS software. This training was organised by the Ministry of Health in collaboration with HISP team members in Mozambique.



Photo 5.6: DHIS Training at Xai Xai district (photographer: Lungo, J.H., Xai Xai district, 24 April 2002)

The Ministry of Health in Mozambique

At the Ministry of Health, I was introduced to SIS before going to Gaza Province, where I was attached to the SISPROG systems administrator who informed me about the main problems with their computer database system. After the process of extracting data from Gaza was complete, we were given an opportunity to present our report (Appendix D number 2) at the Ministry of Health, on 30th May 2002. As a way forward, we agreed that the HISP should integrate ongoing efforts of developing a planning software tool (know as SIMP Pro) for the SISPROG database. In addition, the Ministry officially accepted to organise a training course for the health workers in Gaza province on their expenses. The training was conducted from 23rd September to 3rd October 2002 at Chicumbane Health College in Ganza province.

DHIS Training workshop at Chicumbane College of health

On September 2002, the Ministry of Health in collaboration with the HISP team organised a 10-day training workshop for health workers in Gaza Province. In that workshop, of which I was one of the facilitators, health workers were trained on how to create data records and to create analysis report using the DHIS. Appendix D.3 presents the report that we presented at the Informatics department, Eduardo Mondlane University on 29th November 2002, about the DHIS training workshop. In this workshop, the sample data used in the DHIS was that extracted in April 2002 through the ETL software I developed.

5.5 Situational analysis: National Health Information System in Mozambique

This subsection discusses the empirical data collected from the fieldworks after visiting various health facilities conducting interviews, observations, and DHIS training.

5.5.1 Primary tools for data collection

The main focus of the study in Mozambique was to extract and analyze the data captured and enter it in SISPROG. Thus, a selection of data registers was made that can be traced from the district to the national levels. After conducting a series of interviews with

SISPROG system administrator and retrospective inquiry on the paper forms for collecting routine health data, and the computer database system, I understood that the data recorded in the database came from the following four forms at the district level:

- Form A04. Records immunization data reported per district and monthly
- Form B06. Records children consultancies reported per health unit monthly
- Form B07. Records maternity and deliveries reported per health unit monthly
- Form B08. Records pregnant consultancies reported per health unit monthly

These forms are used at the district level to transcribe data from the health facilities. On completion, these forms are sent to the provincial health directorate where data are entered in the computer database system. The computer database (SISPROG) system uses files that are named after these forms, so the fully computerised files are called A04, B06, B07 and B08.

Data Processing at province level

The system is computerized at the province level, where data entered. Data for the Provincial computer database system comes from the following reports:

- Form A04. Records immunization data reported per district and monthly
- Form B06. Records children consultancies reported per health unit monthly
- Form B07. Records maternity and deliveries reported per health unit monthly
- Form B08. Records pregnant consultancies reported per health unit monthly

The computer database system data files are also named after the source manual forms respectively i.e. data file A04 receives data from form A04, the same for B06, B07, B08.

Data Processing at national level

At the national level, the system is computerized and no data entry is done. The data are transferred from the region to the national system through floppy diskettes that are sent to the central level monthly. However, the research revealed that data are also transmitted in paper formats.

5.5.2 Information flows

Based on the fieldwork I conducted in Gaza province through interviews, studying of the data collection forms, reporting procedures, and analysis of the existing technological and medical infrastructure, I describe the structure of the Health Information System in Mozambique, and I give an overview of the information flows within the district health system. These information flows are also reflective of the prevailing HIS structure at the health facilities, district, province, and national levels in the country.

The health management information system (HMIS) consists of a range of health facilities, institutional centres, and their staff such as health posts and centres, health district offices, provincial health offices, national health office. These health facilities and institutional centres are inter-linked in order to provide services such as health care and reporting of health data. The HMIS in Mozambique started in 1982 and data systematically flowed from the health facilities to the Ministry of Health. The HMIS was revised in 1989 in order to simplify the data collection artefacts. The computer database system came into place in 1994. Since then, little change, especially of the data collection forms redesign, has taken place. The system still follows the same schema of 1982 of collecting and reporting health data.

The HMIS system has four defined administrative levels namely; community and health facilities (health centre, health post, hospital), district health directorate, provincial health directorate, and the HMIS section of the Ministry of Health. Figure 5.1 shows an overview of the health information system structure in Mozambique.

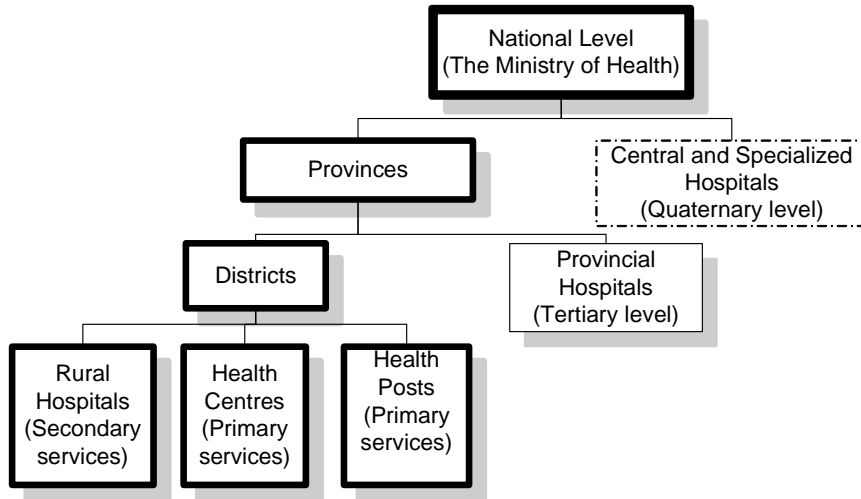

Figure 5.1: The Mozambique health services structure (Kaasbøll and Nhampossa 2002, p.509)

At every community level, there is at least one health facility that provides health care services and consequently collects health data. The data are being collected using forms and registers. Usually, there are daily data registers, the totals from those daily data a register adds up the monthly data at the end of the month and then sent to the district. The data being reported by the health facilities can be categorised into four groups:

- ❑ **Child Immunisation health service data:** These are reported as they are, without being aggregated to the district. At the district level, these data are aggregated into one figure, and then reported to the provincial health directorate.
- ❑ **Infectious disease data:** These are reported on a weekly bases and when an outbreak occurs. Cases like cholera or acute malaria are examples of infectious disease data. These data are reported to the district and sent to the province, where they end up into a computer database.
- ❑ **Routine health data:** Such as number of outpatient's attendance, are collected in daily basis, then are aggregated at the end of the moth to form a monthly report which is reported to the district level. The district then collect these monthly reports from the various facilities in the district, and sends to the provincial health directorate office where they are entered in the computer database.

- **Semi-permanent data:** These are administrative data like number of staff at the health facilities, number of beds, population census, etc. that remains unchanged until the end of the year. Health facilities prepare annual reports then send to the districts where they send to the provincial health directorate.

At the district level, data are accepted as they are, only when a major problem occurs like if a health facility did not report, the district tries to communicate with that particular health facility.

Bar charts and linear graphs showing various trends of reported health data decorate most of the walls of the health facilities and district health statistics offices. That shows that the health workers are doing their best to analyse the health data.

Health data are collected, processed, and stored in a paper-based system at the health facilities and at the district level, but at the province level, the health data are stored in a computer database and other spreadsheets and texts files.

Communication between and across health facilities and the district levels is essentially paper-based; although all four districts covered in this study have computers at their district health offices.

In reporting health data from the health facilities, the distance between the district health office to that health facility matters. This is because the health facilities are supposed to send the data to the district on their own means, regardless the fact that most of them have no transport facilities. The roads are poor as observed in Manjacaze rural hospital and Julius Nyerere health post, and communication has to take place mainly by a person going on a bicycle. During rainy seasons, most of health facilities get blocked and thus can not manage to send data to the district at all or with significant delays It should also be noted that, the transportation problems affect also the distribution of drugs, transfer of

patients from one facility to another, supervision trips, and distribution health data registers.

The general problems of the health information system in Mozambique regarding information flows can be summarised as follows:

5.5.2 Problems related to information flows

Completeness

Not all health facilities send report to the district health office (see Table 5.1).

Table 5.1: Chibuto district health office: Reporting of health facilities

Health facility	Total required reports	Reports received	Missing
Chibuto-Sede	13	13	-
Malehice	13	11	2
Muxaxane	13	9	4
Maievene	13	13	-
Alto Changane	13	11	2
Chaimite	13	-	13
Chipadja	13	-	13

Source: Chibuto district health directorate, 2002

Correctness of data

Health workers at the health facilities are doing much work but reporting less, because they do much work during the day and in the afternoons, they try to remember what they have been doing during the whole day for reporting purposes. ‘Lack of personnel’ is one of the issues that influence this problem because one person performs many activities and according to them, it is important to do these activities, rather than filing endless forms.

On interviewing one district director of health, he argued that,

“We are very few here in our hospital, you cannot attend the patients at the same time you complete the registers, people will sleep here and the patients will get angry of you. So, we used to complete the forms at the end of the shift” (Health director, Bilene district health directorate, 25 April 2002).

In Chapter 7, I present the analysis of the health data using the DHIS software. You will find that usually the data have little correlation with each other like having more deliveries than the number of children (live and death) signed out.

Timeliness

For each level of information flows there is a deadline to send reports to the upper levels. These deadlines are not often followed due to many factors, such as the transport problem mentioned above. Therefore, not all reported data have reached the next level on time, and always, there are delays of health reports. Another factor is the presence of very few health workers in the health facilities.

Feedback

Data are collected daily, weekly, and monthly at the health facilities and sent to the upper levels. From the district health offices, no one sends an answer of a well-done job to the health facilities. Instead, there are many complaints on something done wrong or missing, constituting the main feedback. This does not give an incentive to the people collecting data and is discouraging.

When discussing with one trainee at the DHIS training Workshop at Chicumbane College (September to October 2002), I asked the trainee, “why do you think the course is useful for you”, and she said,

“... this DHIS will help me to clean up my data before I present them to those people at the province, because those people do not acknowledge our work if we do good, but if you submit wrong data, they will point to you a finger” (Trainee, Chicumbane College, 02 October 2002).

Poor analysis of data

While learning to enter data in the SISPROG database at the province level on 22 April 2002, we spotted a report from one district typed through typewriter. There were strange figures and typing errors that even the statistic officer of Gaza province said, “no, these figures are wrong, do not enter them”. However, the district health director of the issuing district had signed the report.

Lack of resources and office space

This is another big problem. For example, at Julius Nyerere health post, the space seems to be quite limited as compared to the number of patients attended to. All patients have to stay outside, regardless of the hot sun and even when it was raining. Forms, and boxes of drugs have to sit on the floor.

At another office of health statistic officer at Chicumbane rural hospital, one interviewee said,

“we do not have folders that is why my room seems to be not organized and I am shifting these records of the last year to put them somewhere else and use this folder for the records of this year” (Statistic officer, Chicumbane rural hospital, 25 April 2002).

However, although the situation of resources is not good, the people I found have never stopped working because of the lack of resources, they try to do the best they can to not stop the routine health service delivery.

5.5.3 The operation of the national computer database (SISPROG)

Data entry part for provincial level

The provincial statistic officer is responsible for SISPROG at the province and is the one who does data entry. Data are from paper forms received from the districts. The procedures are as follows:

1. Selects a menu in the main screen. Note: a menu starts with the form name
2. Then chose the year, month, and place (district or health unit) to enter data
3. You will be presented with a grid editor like spreadsheet with data element names as the column header.

As described before, the system was finished so the other menus starting with B05, C04, C04H, C05, J01, and K014 were not working.

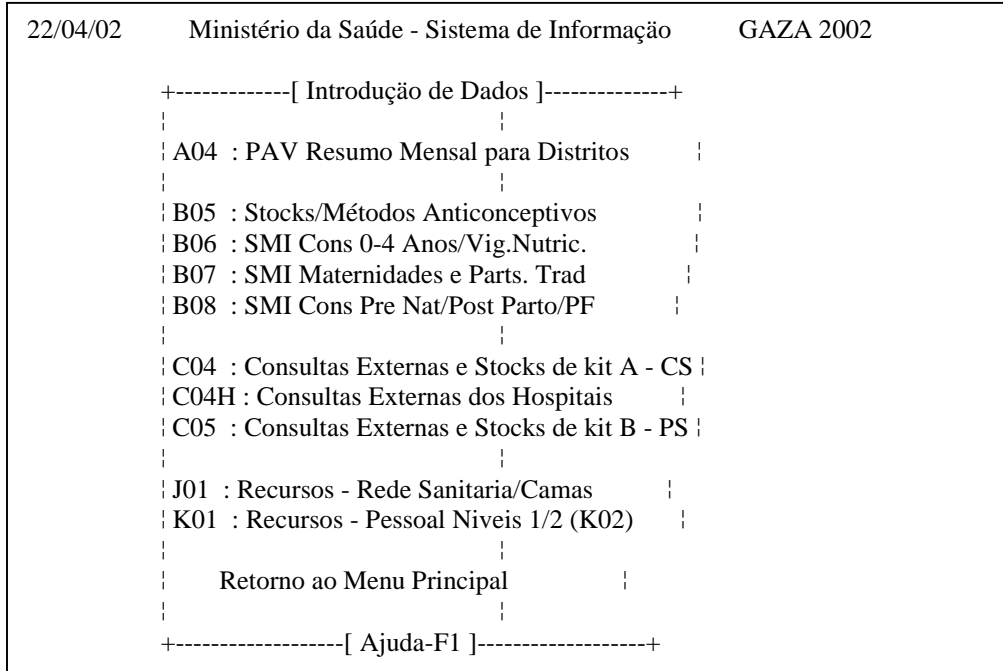

Figure 5.1: SISPROG main screen (Source: Print screen of the SISPROG, Gaza provincial health directorate in Mozambique, 22 April, 2002)

Missing reports

The SISPROG database has functionality to automatically find missing reports and gives its user a list of missing reports. With this list, the province can request the forms from the districts, which have not delivered. A tool called 'VERI.EXE' makes text files containing information about duplicate records.

Validation rules

SISPROG contains few validation rules if any. It permits abnormal values like 60%.

Data entry for national

The user only needs to select a diskette with an import file from the province in order to import data. I have been unable to see an example of the importing of data, but I was told that data are imported automatically from diskettes.

Control of data entry in the national version

The SISPROG national version has a function to check the data. It gives a report on empty databases and checks for faulty tables/databases. It also checks for missing reports from districts. It only report up to which month data is reported, it does not tell the user if is one or ten units who have reported. For example, SISPROG will report missing record if 10 out of 10 districts have reported January through November. In this, it will complain that data is only up to date up to November, but only 8% of the data are missing. SISPROG will not report a missing record if 1 out of 10 districts have reported January through December. No months are missing, but 90 % of the data is missing.

Graphical analysing utility for national and provincial computer databases

This utility is a separate program also in MS DOS that allows users to generate graphs and charts with their data. It accesses the data in SISPROG database automatically without requiring the user to re-enter the data again. However, I have not found anyone who actually uses that program because the graphics produced are poor (16 bit colour and does not support 3 dimensions graphics) compared to today's tools. Users exported data to other newer graphical tools such as MS Excel and Lotus spreadsheets.

5.5.4 Other computer application software

It is worthy to mention that, although this study has covered extensively the SIS database, the Ministry of Health has other computer applications that together with SISPROG assist processing health data. In one meeting with health information officer of the Ministry of Health, one officer said,

“ there are about 7 information systems now at the Ministry, we need to think critically to have only one information in the future” (SIMP Pro developer, Ministry of Health, 30 April 2002).

SIMP Pro: An expatriate programmer developed this software in Visual Basic 6.0. Its main function is to pull data from SISPROG database to MS Excel spreadsheets so that users can manipulate the data for planning purposes. Before this program, users had to print the data then retype it again in Excel or Lotus spreadsheets. However, this program

runs on Windows 98/NT/2000 and requires powerful computers than what SISPROG does. Therefore, users have to copy SISPROG data files to those computers where SIMP Pro runs on. To copy big files, users use “ZIP drives” and since not all provinces have “ZIP drives”, the SIMP Pro programmer used to take a round of all the provinces just to copy SISPROG data files to the machine where SIMP Pro runs.

BESPROG: This is a computer database that runs in parallel with SISPROG at the provincial and national levels. It stores data for Infectious diseases that are reported weekly. I found BESPROG and SISPROG running on old computers despite the existence of new powerful computers. As the time goes on, the old computers will perish with vast amounts of health data.



Photo 5.7: SISPROG and BESPROG are both on old computers (photographer: Lungo, J.H., Xai Xai district, 22 April 2002)

Spreadsheets and word processor applications software: these sum up the list of computer application software of HMIS in Mozambique. Most of the computers donated at the districts are installed Microsoft Excel and Microsoft word. The provincial health directorate has Lotus spreadsheets in addition to the existing application software.

5.6 Progress of HISP project in Mozambique and discussion

5.6.1 Background

The first approaches from HISP team in South Africa to the Ministry of Health in Mozambique looking for possibilities of using the DHIS software in Mozambique were made in 1997. In July 1998, a proposal to make Eduardo Mondlane University (UEM) a counterpart University to University of Oslo (UiO) was accepted. Eduardo Mondlane University has three learning districts namely Maxixe in Gaza province, Cuamba in Niassa province, and Chokwe in Gaza province. A proposal to the Ministry of Health to introduce HISP in the three Eduardo Mondlane University “learning” districts was accepted. In 1999, a study on Information use survey was carried out in three districts, and PhD students to University of Oslo were identified on quota funds. The DHIS software was introduced in the three pilot districts. In 2000, six PhD students (three for informatics, and three for medical) started at the University of Oslo. The first HISP training for 3 provinces in Inhambane was carried out in the year 2000. One PhD student has dropped after six month. A replacement was taken and has also dropped. In 2001, more training was done in Cuamba district in Niassa province and an Integrated Masters Programme for M.Sc. Informatics started at UiO in August; and MPH started at UEM in October.

This study was conducted in collaboration with HISP team members and all outputs of this study in Mozambique is regarded as also are outputs for HISP Mozambique. Thus, in the year 2002, a software was developed to extract data from SISPROG to the DHIS; at the time of writing, the DHIS was populated with health data from 1999 to April 2002 from six provinces; onsite training was performed in Bilene, Xai Xai, Manjacaze, Chokwe, and Chibuto districts; and DHIS training workshop which involved 40 trainees was conducted at Chicumbane College in September 2002.

5.6.2 HISP strategy

HISP was introduced into Mozambique through Eduardo Mondlane University in collaboration with the Ministry of Health. Once the PhD program was started, it was

envisioned that the PhD students would drive the process whereby the Informatics students leading the technical informatics component and the doctors provide the health inputs. While this strategy has its advantages of providing a research and development component for the University, it has a number of difficulties in that the locus of the HISP development team is outside the Ministry of Health, and therefore has no inherent power base and have reduced access to provincial and district structures. In addition, the PhD students have their responsibilities, which are often in conflict with the project facilitation activities.

5.6.3 HISP project management

In 2002, the HISP project chairperson was from MISAU and the two coordinators from UEM and UiO respectively. This achieved both a balance of academic, ministry, and international interests. Members of the HISP project committee came from both UEM (PhD students) and MISAU (leadership) and this was designed to ensure that the Ministry of Health would own and drive the process and strategies of HISP project. This HISP project committee met regularly.

5.6.4 Software management

The HISP software, District Health Information Software (DHIS), from South Africa was introduced in Mozambique in 2000. When DHIS was introduced in Mozambique, it was in English, while the users are Portuguese speaking. A process of translating the program was started, but because the caption strings of the software were hard-coded, each new version had to be re-translated. The release of new versions occurred before the previous version was fully translated into Portuguese, and thus, the process was resetting every time. Translation process was a problem, and thus, led to no new versions of the DHIS have used, for the whole year of 2000. It was not until 2001 that the software was put on a multilingual database, where, caption strings, data definitions, and indicators strings could be translated and used into new versions. Thus, the use of the DHIS in the pilot sites started in the year 2001.

5.6.5 Installation and use of DHIS

In the districts, the software that had been installed was hardly used, partly because of the English factor, but also because of a lack of local technical support at the district and provincial levels. The software was sometimes difficult to install, particularly on older computers, and there were no capable local technicians involved, so installation depended on the PhD students. The frequency of the visits of the PhD students to the pilot sites was irregular, and it took too long for them to visit the DHIS pilot sites again. While conducting my study, I experienced a DHIS installed in Chibuto six months ago and since then, the technician had never established a contact with the users until on the day of our visit. The same was the case in Xai Xai, where there was nearly a 12 month gap after the first installation of the DHIS.

At the provincial level, the use of the DHIS is not mandatory for health statistics officers. Since it is compulsory to use SISPROG and not DHIS, users opt to forget the DHIS because it is an extra work to work on the two systems. Although the SISPROG has been victimised for its poor report generator, and the DHIS was populated with all historical data from SISPROG. However, there was no use of the DHIS at the provincial level. However, the non-use of DHIS at province level can be attributed to poor training of the provincial health officers on how to use the DHIS and because no order from the Ministry of Health that mandate the use of the DHIS. As per this study, no reports ever produced by any province using the DHIS found. The national HIS section of the Ministry of Health has the latest version of the DHIS with almost all historical data from SISPROG. This study did not dig further to find out whether the Ministry of Health is really using the data on the DHIS or not.

5.6.6 DHIS prototyping processes

In this study, I could not find any competent DHIS user who could comment on at least to one of the reports produced using DHIS. It can be argued that, the DHIS system, which was developed using a prototyping approach in South Africa, can be described as being introduced into Mozambique in a top-down approach with minimal interaction with

users. This is because the technicians spend little time in the districts talking to the users, which led to the level of DHIS users to be very low, with little capacity to identify problems or propose improvements. It could also be argued that the lack of fully approval of the Ministry of Health to mandate the use of the DHIS also slowed down the creativity of users in evaluating the DHIS and hence to comment on the design of the DHIS.

5.6.7 DHIS training

The HISP team has carried out four mass training sessions, an initial session in 2001 for all three provinces and then training in each of the three provinces. At each of these training sessions, 40 to 60 people were trained the basics of computer use, the HISP approaches and analysis of data using the DHIS. Participants came from different provinces and districts and have a variety of backgrounds. In the last DHIS training workshop conducted on September 2002 at Chicumbane Health College, some of the trainees come from Chigubo district, a district with no electricity and thus no single computer existed there. It was obvious that those participants from that district will not use the knowledge gained in that training.

While the strategy of training many users at a time can be seen as a political brokering approach that aims at introducing the DHIS in the districts, there is no tangible success of the strategy. There were a number of problems with the DHIS training strategies:

- ❑ The approach of sending a large group of lecturers to the province for two weeks to training users and then sending participants back to the districts with minimum support of users thereafter, was not cost-effective.
- ❑ Many participants had no computer skills at all, and after the course participants returned to districts where there were no computers and could not use the training skills afterwards.
- ❑ Selection of participants was not made on clear criteria and many people who were trained should not have attended the course. The classes were too big for real learning to occur.

5.6.8 Success of the HISP project in Mozambique

In summary, the success of the HISP project includes fully translation of the DHIS into Portuguese, creation of training manuals, population of the DHIS with real Mozambican health data, and maintenance of an up-to-date list of the health facilities in their pilot sites.

5.7 Chapter summary

In this chapter, I presented descriptions of the research settings in Mozambique. Then a situational analysis of the health information system was presented followed by a discussion of the HISP progress in Mozambique. In both discussions, the situational analysis of the health information system and HISP progress were based on problems found. As this is an action study, the analysis of the problems of the current situation is the most important part of action studies as this initiate the circle of the action study phases.

CHAPTER 6

CASE STUDIES IN TANZANIA AND DISCUSSION

In this chapter, I present the case study sites in Tanzania, the situational analysis of the health information system in Tanzania, and the progress of the HISP project in Tanzania. The chapter is structured as follows: Section 6.1 presents the fieldwork design, Section 6.2 presents the case study sites in Tanzania, Section 6.3 present the situational analysis of the HIS in Tanzania and Section 6.4 presents the progress of HISP project in Tanzania.

6.1 Design of the research fieldwork

I conducted the fieldwork in Tanzania from June to August 2002. Due to the experience gained in Mozambique, I realised that I needed to visit health facilities (health posts, dispensary, health centres, and hospitals), regional medical office (RMO), and some Non-Government Organizations (NGOs) that were involved in health delivery practices to enable me to trace the flow of health data from health facilities, to the national level, and to other stakeholders like the NGOs.

I approached the Permanent Secretary Office of the Ministry of Health in Tanzania to give me an introduction letter (attached as Appendix C) in order to visit the public health facilities at the district, regional, and national levels. For the NGOs, I had to approach prospective organisations and "convince" their top management staff to participate in the research project. This, in all cases, involved a negotiation process in which I had to explain, in the following order: (1) what the research would contribute to the organisation, directly and indirectly; and (2) what their organisation was expected to contribute, in the form of staff time, equipment, and facilities.

In order to explain the first point, and thus to justify the second point, I had to declare in a comprehensive way that the research hypothesis is that the introduction of computer database at district medical offices could politically improve the accessibility of health data and speedup the processing of health data.

I also had to present a clear plan for the research project, including project goals and a time schedule. In Mozambique, I had carried the research without a clear research plan, as I was part of a research team, the HISP team in Mozambique. My experience suggested that this plan benefited from a well defined research framework, which led to a clear idea of the number of health facilities, RMOs and NGOs to be facilitated, how interviews would be conducted, how much data would be collected, how data analysis would be carried out, and, finally, how long would each of these activities last. A research framework can take the general form of research questions, units of analysis, and research variables. It can go even further and include assumptions about the phenomena being observed, a more elaborate theoretical framework, or an explicit set of hypotheses to be tested (Kock 1997). I adopted a research questions based framework as presented in Chapter 1 of this thesis. It is important to stress, though, that both the research framework and the initial plan were continuously changed along the research project.

As a result, I listed down some health facilities in Bagamoyo district. Since Bagamoyo belongs to Coast region, the regional medical office of Coast region was included in the study. The external organisation that accepted to participate in my research were Adult Morbidity and Mortality Programme (AMMP, NGO) and the United States Agency for International Development (USAID). This enabled me to study the flow of health data from the source (health facility) to the national level and to other stakeholders.

I expected to interview forty (40) health workers, however, I interviewed 32, turning the coverage to 80% of the expected sample size. The results of the interview responses were divided into two parts: from organization units that perform the actual health delivering works (dispensaries, health facilities, and hospitals) and those from organisation units performing the administrative works (District Medical Offices (DMO), Regional Medical Offices (RMO), Ministry of Health (MoH), and external agencies. Of the 32 health workers interviewed, 22 (68.8%) were male and 10 (31.3%) were female. Ten health workers (31.3%) were from the health delivery units (dispensaries, Health centres and hospitals), 5 (15.6%) from the District Health Office, 2 (6.3%) from the Regional

Medical Office, 7 (21.9%) from the Ministry of Health and 8 (25.0%) from external organisations (Table 1 in Appendix F). However, the results presented in chapter 7 do not show any correlation with the gender of the informants but there is a correlation with the type of the organisation units. For example, while administrative units have data managers, health delivery units do not.

From Table 5 in Appendix F, it is seen that the majority of health workers interviewed (62.5%) had attained University/College education, 18.8% have Ordinary Secondary School Certificates, 15.6% have Advanced Level Secondary School, and only one (3.1%) of the interviewees had attained Primary School Education. Again, the difference of the education levels between the informants did not make a difference. Many have informed about the same issues regardless of their educational levels. For example, I interviewed one driver (who has primary school education), about the distribution and use of drug stock information, as he is the one who drives the drug kits to the health centres, dispensaries, and village health posts. To my surprise, he repeated the same information I received from the district medical officer. Then I asked him whether he was used to discussing these problems with the DMO:

“No, not at all, they just give me these boxes, but I do talk with the nurses at the health centres because they believe I can report those problems to the government (driver, Bagamoyo district medical office, 26 June 2002).”

For the purpose of analysis of the empirical data, I have grouped the health workers' job categories into four groups, namely:

- ❑ Service Providers (Doctors, Nurses, Matrons, Traditional Birth Attendants, and all those who see and attend the patients).
- ❑ Medical Officers (Regional Medical Officers, District Medical Officers, and Clinical Officers).
- ❑ Data Managers (Health Data Recorder, Statisticians, Database Administrators, and Systems Administrators)
- ❑ Managers (Heads of Departments, Manager of NGO, and Directors of NGO)

The aim for grouping the job categories of my informants is to trace impressions of health workers at different levels toward the health information system. In grouping the

informants like this, 25% were Service Providers, 28.1% were Medical Officers, 31.3% were Data Managers, and 15.6% were Managers. Note that the distribution of their work categories is also equal in each group. Figure 6.1 is a map of Bagamoyo district that presents locations of the health facilities in the year 2002

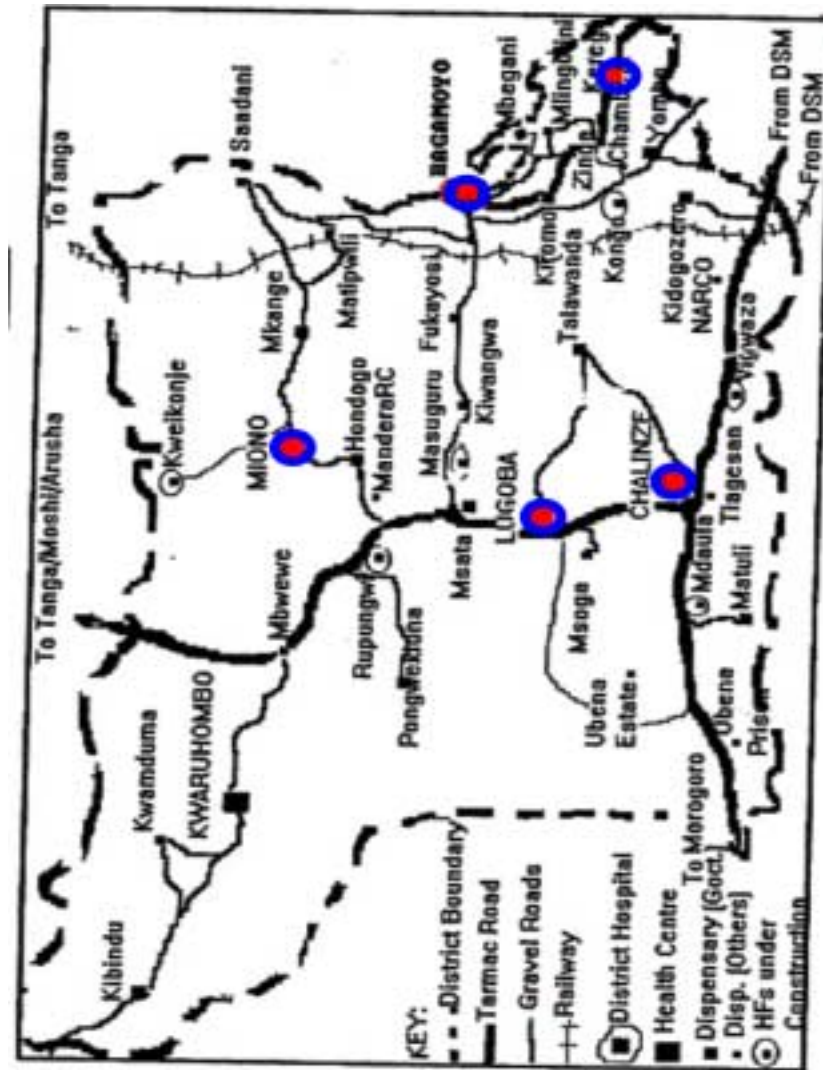



Figure 6.1: Bagamoyo District Health Facilities 2002 Map (source: Bagamoyo district processing file)

 Health facilities visited

Health facility name	Distance of health facility from Bagamoyo town (in Km.)
Bagamoyo district hospital and DMO	0
Kerege dispensary	29
Lugoba health centre	84
Miono health centre	94
Chalinze health centre	112

6.2 Case study sites

6.2.1 Bagamoyo district medical office and district hospital

This setting was the epicenter of the study. After I received an introduction letter from the Ministry of Health, I started my fieldwork at the Bagamoyo district medical office. Bagamoyo district medical office and the district hospital are located in one place.

First, I started to conduct interviews and group discussion with the district medical offices, then, I acquired a temporary office and collected most of the health documents (district processing file, book recorders, reports and forms) in order to conduct a document analysis. My supervisor joined us in the group discussions and played a big role especially, in the process of political brokering for initiating HISP project and DHIS software. Photo 6.1, presents a meeting of one of our discussions. The results of that discussion with the medical officers allowed me to have full access to their medical records, have a free transport whenever I wanted to visit the health facilities in remote areas and develop a good rapport with health workers at the district medical office.



Photo 6.1: Meeting with Bagamoyo district medical officer

6.2.2 Chalinze health centre

The health centre is located on the main road from Dar-es-Salaam to the northern and central zones of Tanzania. Chalinze is also a business town and a main bus stand for buses heading to and from northern and central regions of Tanzania. Chalinze health centre is a busy health centre, attending more patients than is its capacity. I interviewed

the health workers and the Clinical Officer in Charge of the centre. The health centre was aimed to provide health services for six villages, namely Bwilingu, Pera, Chahua, Pingo, Chamakweza, Msolwa, and Malivundo, which form a total population of 26,000 inhabitants in the year 2001.

6.2.3 Lugoba health centre

Lugoba health centre is also located on the main road heading to the northern zone of Tanzania (Tanga, Kilimanjaro, Arusha, Mara, and Mwanza regions). The centre is delivering health services to seven villages, namely Lunga, Diozile, Saleni, Kinzangu, Makonde, Mindutulieni, and Tukamisasa with a total population of 15,388 in the year 2001. Only two health workers work in the health centre. One is the Clinic Officer in Charge and the other is a midwife nurse. However, there were several volunteers also working.

6.2.4 Miono health centre

Miono is a remotely located area. The health centre serves five villages: Miono, Kikaro, Mihuga, Masimbani, and Kweinkonje villages, which form a total population of 11,787 inhabitants in the year 2001.

6.2.5 Kerege dispensary

Kereger dispensary is located on the main road heading to Bagamoyo from Dar-es-Salaam. Its area of influence is within three villages, namely Kerege, Mapinga, and Kwamatumbi villages, with a total population of 7,146 inhabitants. The dispensary serves many road accident victims.

6.2.6 Coast Region Medical Office (RMO)

Coast region is one of the 25 regions of Tanzania. The regional medical office is located in “Kibaha Mile Moja” city of Kibaha district. The regional medical office receives data from all districts and it supervises the regional referral hospital, Tumbi hospital. I have been there to learn how they receive, store, and analyse health data from the districts. Another important aim was to learn the HMIS computer database, MTUHAPROG. On my first day of visit at the RMO I was with a peer researcher and my research supervisor.

The regional health statistics officer received us and we had two hours interview with her.

6.2.7 Other case study sites

Other visited places include MTUHA section of the Ministry of Health, Adult Morbidity and Mortality Project (AMMP) head office in Dar-es-Salaam and United State Agency for International Development (USAID) headquarter in Dar-es-Salaam.

6.3 Situational analysis of the HIS in Tanzania

The health information system (HIS) in Tanzania is under decentralization process to empower the district levels. In the year 2002, the Ministry of Health has distributed computers to all district medical offices in Tanzania, to assist processing of health data and other secretarial activities. Also, all health facilities at the district are no longer under the Ministry of Health, but under the Ministry of Home Affairs and Local Government.

6.3.1 Aims of health sector

The overall aim of the health sector in Tanzania is “to improve the health and well-being of all Tanzanians with focus on those most at risk, and to ensure that health services are responsive to the needs of the population” (MoH-TZ 1998, p.6).

6.3.2 Organisational structure of health services

Before independence, 1961, colonial governments, native authorities, NGOs, and private practitioners ran health services. The distribution of the health services depended on the reference of individual institutions. This led to a situation where some areas had more health facilities than others. After independence, the health plan implementation aimed for a more equitable distribution of services. Today, the organisational structure of health services in Tanzania is as shown in Figure 6.2.

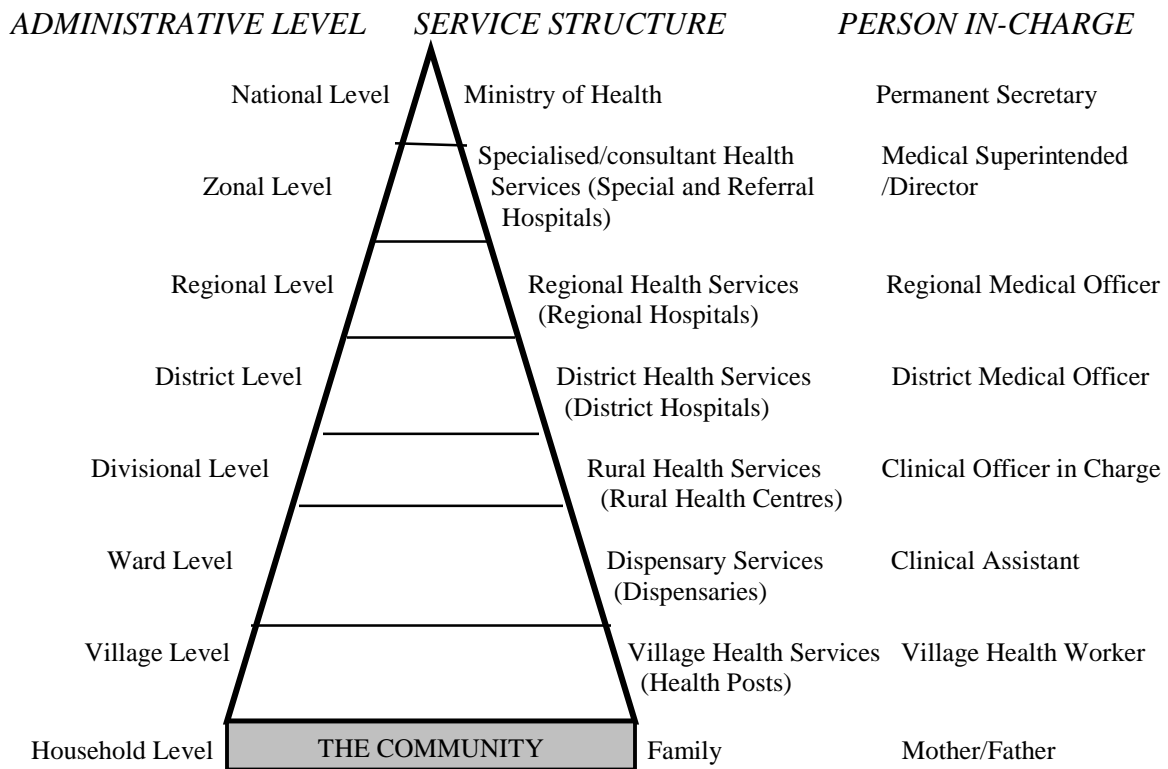

Figure 6.2: Organisational pyramid of the Tanzania health services structure (MoH-TZ 1998, p.7)

The development of health management information system concepts and material began in 1989/90, and “the first version of the HMIS material was finalized and translated into Swahili by April 1991” (MoH-TZ 1993, p.14). The main goal is to optimise the performance of the health sector through the development of a health system. This will enable the provision of guidelines for routine collection, compilation and use of data and to provide necessary and sufficient information needed by health managers at all levels of the health care system for monitoring, evaluating and planning their activities. The HMIS includes all data that is routinely collected at health units and integrates all programmes at unit and district levels. The system summarises the level of performance at each level of health administration using indicators, target values, and threshold values.

6.3.3 Management of health services

In Tanzania, the administration and management of health services is done through the following authorities:

Ministry of Health

The Ministry of Health is responsible for health policy formulation, running of national consultant hospitals, specialised hospitals and District designated hospitals. The ministry is also responsible for health training institutions and workforce development.

Prime Minister's Office (PMO)

The Prime Minister's Office is responsible for running the district and regional hospitals. Local Government Authorities (under PMO) manages health centres, dispensaries, and village health posts.

Non-Government and religious organisations

According to the health management information system implementation plan 1992 – 1996, the NGO health sector accounts for about 35% of all health facilities in Tanzania (MoH-TZ 1993).

Industries

Industries provide health care mainly for their employees and their families through a network of hospitals and dispensaries they own.

Private practice

Doctors are allowed to run their own hospitals, or dispensaries.

Traditional practice

Over 40,000 traditional healers have been identified and 3,000 herbs have been analysed. They are important health resources available at community level. Furthermore, “there are 32,000 Traditional Birth Attendants (TBA's) in the country, an estimate of 4 TBAs in each village among 8,000 villages” (MoH-TZ 1993, p.6).

6.3.4 Primary tools for data collection

These are tools used for data collection and compilation. To describe this, situations of processing health data at the health facilities, district, regional and national levels are described.

Data processing at the health facility level

The health facility is responsible for patient care and preventive services. When they provide these services, information is generated and documented in registers, ledgers, and forms, the primary tools for data collection. These tools are classified as follows:

Book No. 1: Guidelines Manual

Used as a reference by health facility staff, this book explains how to collect and compile raw data.

Book No. 3: Community Book

In Tanzania, each community is assigned to one health facility that belongs to the government or NGOs. Staff from those health facilities are supposed to conduct community outreach to improve the environment, knowledge, and community health. The HMIS provides a register known as a community book for recording information about that community e.g., total population, deaths, births, etc. These books are kept at the health facilities and taken along on each community outreach visit.

Book No. 4: Ledger Book

This book is used to collect the information that is used for monitoring the flow of drugs and other medical supplies. Keeping it up-to-date allows for monitoring to avoid stock-outs and oversupplies.

Book No. 5: OPD Register Book

The register is used to collect outpatient details, such as person attending, his or her name, village/street, age, and sex; new attendance; diagnoses; return visits; referrals; and treatment. The last pages of this register are used to record notifiable diseases. Information about laboratory results and immunization status is also included.

Book No. 6: Antenatal Register

This register is used to monitor pregnant mothers, from their first visit to the health facility up to the last visit of their pregnancy. Information recorded includes date of first

visit, re-attendances, risk factors, and whether the last child born to the mother is still alive.

Book No. 7: Child Register

This register is used to record information about all of the children who come to a health facility, including newborns, children transferred from other facilities, and children who are registered during community outreach. The main function of this register is to monitor all child immunizations. A child is monitored until he or she reaches the age of five years.

Book No. 8: Family Planning Day-to-Day Book

This book is used to record all family planning clients, including those who are continuing with the program and new acceptors. The register keeps track of the quantity of contraceptives supplied to customers.

Book No. 9: Diarrhea Treatment Corner (DTC Register)

This register is used to record information about the management of all patients referred to the DTC from OPD and MCH clinics. Data recorded include date, name, village, age, weight, degree of dehydration, amount of oral dehydration salts (ORS), registration number, symptoms, treatment other than ORS, time spent at the facility, and outcome.

Book No. 11: Dental Register

Used at dental clinics, this register tells the health centres or hospitals that provide emergency oral care the patient's name, village/address, sex, age, diagnosis, referral, whether he/she is a new or returning patients.

Book No. 12: Laboratory

This is a record of work done in the laboratory. It includes date, serial number, name, age, sex, patient number, investigation, test requested, results, abnormalities, and remarks.

Delivery Register

The register contains information both on mothers and their newborn babies. It is supposed to be used at the health centres and hospitals, but due to the births taking place even at the dispensaries. This register can also be used at that level.

Tools for health centers and hospitals

Register for admission

This register is used at health facilities that admit patients. Information recorded in it includes inpatient number, ward, name, address, next of kin, age, date in, diagnosis, final status (recovered, improved, died), and date out.

Forms

Forms for data collection tally sheets and monitoring are:

- ❑ **F201 Child Tally Form:** This form is used to capture children's attendance and to record the weight of children who come for measles immunizations.
- ❑ **F202 Immunization and Vitamin A Tally Form:** This form records information on immunizations and vitamin A supplementation for children.
- ❑ **F203 General Tally Form:** This form is used to prepare summaries from different registers
- ❑ **F204 Neonatal Tetanus:** This form is used to monitor neonatal tetanus disease.
- ❑ **Inpatient Treatment Form:** This form records information kept in the inpatient register.

Secondary data book

Secondary data books are health facility data book for reporting. Details of these books are as follows:

Book No. 2: Health Facility Data Book. This book contains summaries that are transcribed from the primary books. It also has different tables that are used to do simple analysis. The book is organized by management topics by which final management indicators are computed. Summary tables and management indicators are put in the following groups:

- ❑ Information on administration issues, including information on personnel, finance, and performance indicators
- ❑ Community outreach
- ❑ Target population estimates, provided by district Council Health Management Teams and used as denominators in computing various performance indicators such as
- ❑ Monitoring of drugs and consumables,
- ❑ Information on outpatients,
- ❑ Information on inpatients,
- ❑ Information on laboratory,
- ❑ Dental clinics, and
- ❑ MCH services.

Book No. 10: This book includes forms that are used to prepare health facility reports, including:

Staff listing form F001 (reported by all health facilities).

This form is completed and submitted at the beginning of the year. All staff employed at the health facility are listed on this form, with specific information about each staff member. The form is completed in duplicate; one copy is kept at the health facility, and one is sent to the office of the District Medical Officer (DMO).

Equipment inventory form F002 (reported by all health facilities).

Completed and submitted at the beginning of the year. This form lists all equipment. In large health centres and hospitals, separate pages can be used for each department or section. The form is completed in duplicate; one copy is kept at health facility, and one is sent to the DMO's office. (If a department wishes to keep a copy, the form is completed in triplicate).

Physical structure inventory form F003 (reported by local government health facilities and all government hospitals). This form, completed at the end of the year and submitted

immediately, lists all rooms in all buildings. It is completed in duplicate; one copy is kept at the health facility, and one is sent to the district medical officer's office

Health facility quarterly report form F004 (reported by all health facilities).

This report is filled at the end of each quarter (at the end of March, June, September, and December). All of the information is described in the Guidelines Manual, and recorded in the health facility data book (Book No. 2). The form is completed in duplicate; one copy is kept at the health facility, and one copy is sent to the district medical officer's office

Health facility annual report form F005 (reported by all health facilities).

This report is filled out at the end of the year and submitted immediately. Based on data collected throughout the year, the form is completed in triplicate: one copy is kept at health the facility, one copy is sent to the district medical officer's office, and one copy is sent to the regional medical office (RMO).

Renovation/Maintenance report form F006 (reported by local government health facilities and all government hospitals). This report records equipment repair or replacement and renovation and maintenance work done at the health facilities during the year. The form, which is submitted at the end of the year, is completed in duplicate; one copy is kept at the health facility, and one copy is sent to the district medical officer's (DMO's) office.

Equipment breakdown report form F008 (reported by local government health facilities).

This report is filled when and if there is a breakdown of any essential equipment at the health facility. Each breakdown is reported only once. The form is completed in duplicate; one copy is kept at the health facility, and one copy is sent to the DMO's office.

Notifiable disease report form F009 (reported by all health facilities).

This report is required immediately when a notifiable disease is suspected by the health facility. It is sent to the district medical officer's office as soon as possible.

Data processing at the district level

Districts get their raw data from health facility reports. Once the report is received the data is transcribed immediately into the district-processing file (DPF). The file has the working sheets that are used to transform transcribed data into district aggregates and indicators. In general, the district-processing file is paper-based database at the district and is used in the same way as the health facility data book (Book No. 2). In Figure 6.3, the box files are the “district-processing file”.

Structure of the district-processing file (DPF), the paper-based database

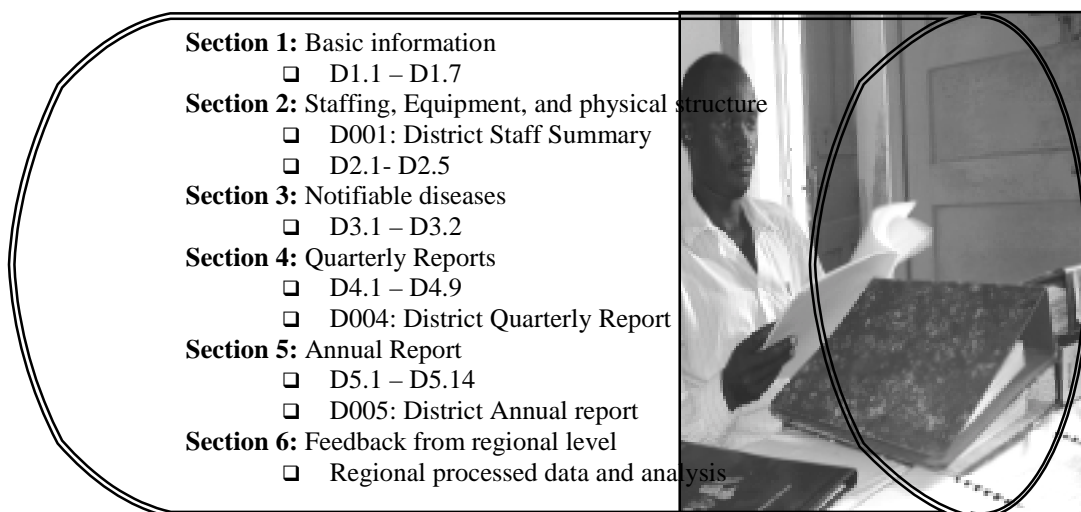

Figure 6.3: Structure of MTUHA district-processing file (DPF)

The district reports

District staff list (D001): This report is prepared at district level and sent to the region at the beginning of each year.

District quarterly report (D004): This report is prepared at district level and sent to the region at the end of each quarter.

District annual report (D005): This annual report is prepared at district level and extracts information from the 'F005' report from the health facilities.

Data processing at regional level

The system is 'computerized' at the regional level, where data are entered in a computer database system. Data for the regional computer database comes from the following reports:

- ❑ Annual Health Facility Report (F005)
- ❑ District Staff list (D001)
- ❑ District Quarterly Report (D004)
- ❑ District Annual Report (D005)

Data processing at national level

At the national level, the system is computerized and no data entry is done. The data are transferred from the region to the national system through computer diskettes that are sent to the central level monthly.

6.3.5 Information flows from the health facilities to the higher level

At the Ministry of Health, there are many receivers of health data/information reported from the health facilities. For example data for infectious disease week ending (IDWE), Traditional Medicine, Reproductive Health, Pharmacy and Supplies, Mental Health, Oral Health, Laboratory, and HMIS are among of the sections of the Ministry of Health that receive data from the health facilities via district levels and regional levels. However, since this study is focused primarily on HMIS data flow, Figure 6.4 presents the HMIS reporting system.

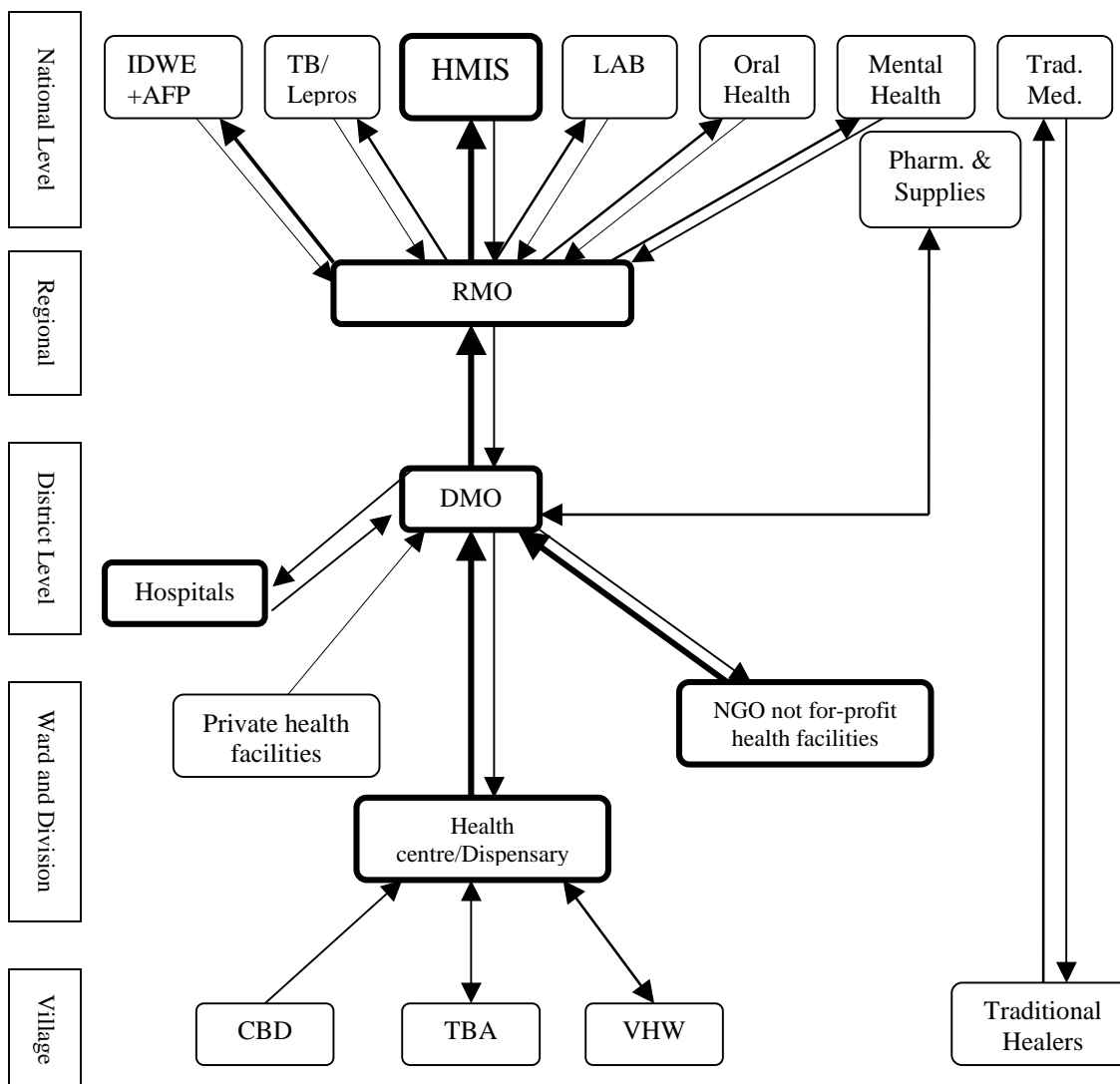

Key

CBD: Community bases distributors DMO: District Medical Office
 TBA: Traditional Birth Attendants RMO: Regional Medical Office
 VHW: Village Health Workers —→ one-way data flow ↔ two-way data flow

Figure 6.4: Health management information reporting system in Tanzania (MoH-TZ 2000)

6.3.6 Problems of the health information system

The HMIS in Tanzania is not without its problems related with the collection, compilation, analysis, storage, and transmission of health data. In this subsection, I present some of the problems.

Incompleteness reporting

For health data to be useful to the health planners and decision-makers, data reported should represent the actual situation of the health delivery services of the reporting district. One measure to ensure that data reported represents the actual situation is emphasising that all health facilities that are required to report must report (complete reporting). Through the analysis of Bagamoyo district health data reported at the district-processing file in the year 2001, this study found that 20 (47.6%) health facilities did not submit all required reports at the district level.

Incorrect data

The process of transcribing data from the primary data registers to monthly and quarterly reports is resulting in wrong figures because of human errors. For example, summing up of all outpatients recorded daily to make the totals for that particular month may result into wrong figure. In this study, I came across one report from one health centre that has many mistakes.

Untimely reporting

Data should reach the next level on time. However, this is not always the case. Reports from the health facilities are reported at the district level one to three months after they are due and reporting from the district to the regional level takes even longer.

Poor analysis of health data

The level of analysis of health data at the health facility and district level is generally poor. The HMIS review team of the year 2000 also reported that, “there is poor information products available from the district, regional, and central levels, and no evidence that show how the data analysis is being used for planning and evaluation” (Rubona, 2001, p. 192).

Feedback

This study revealed that the feedback given to the health facilities is not formal and usually involves oral feedback, which happens during the supervision trips from the

district. At district level, although the district-processing file has a chapter for recording feedback from the regional levels, this study found no single documents, except a schedule of when the regional medical officers will visit the district medical officers.

Lack of resources and office space

Most health facilities have reported the problems of availability of data registers and office space to store the data registers. In Bagamoyo hospital, patients often have to share beds. In addition, through checklists I found some deficiency in data collection and analysis tools, such as data registers, and calculators. Table 6.1 presents interview results I conducted to determine whether data registers are available all the time or sometimes.

Table 6.1: Type of Organisation * Availability of Data Registers Crosstabulation

Type of Organisation		Are data registers available?	
		All the time	Sometimes
Dispensary	Count		2
	% within Type of Organisation		100.0%
Health Centre	Count		6
	% within Type of Organisation		100.0%
Hospital	Count		2
	% within Type of Organisation		100.0%
DMO	Count	1	4
	% within Type of Organisation	20.0%	80.0%
Total	Count	1	14
	% within Type of Organisation	6.7%	93.3%

Absence of information strategy/policy guidelines

This study revealed 15 parallel systems that are not coordinated centrally by HMIS including national, sentinel site-based, and some project or donor-initiated. The current procedures for reporting information from lower to higher levels and feedback from higher to lower levels are ineffective in that no specifications on what to feedback, and feedback usually happens if a lower level did not report at all. There is no standard procedure for sharing information among departments within the Ministry of Health, other ministries, or other stakeholders. There are separate databases in the Ministry of Health, like IDWE, LAB, Oral Health, HMIS, TB/Lepros, etc., and each department, program, and project is responsible for the data it collects (see Figure 6.4 above). Also, there is neither information officer with a detailed and comprehensive overview of health

information available nor information unit responsible for information and communication of the separate programs.

6.3.7 Operation of the computer database, MTUHAPROG

Before the year 2000, the HMIS in Tanzania had a computer database developed in dBase IV. Since then, the database has been reviewed several times. It was decided that the database should be replaced because of technical reasons that make its operationally cumbersome and most of the time the database is down. In middle 1999, a local software company was contracted to develop a new computer database for the Ministry of Health that will facilitate the capturing and processing of health data. A donor to pay for that software was identified and paid directly to the vendor, instead of giving the money to the Ministry of Health. This created some confusion because the Ministry of Health felt that not controlling payments leads to them having no say in the software development process.

The software was delivered and rolled out in all regions in the year 2000. A formal training of the software was arranged where the HMIS section of the Ministry of Health officers were rotating all over the country to training the health statistical officers at each regional medical office. The software become fully operational in the year 2001. That computer database system was developed in Microsoft Access 97. While replacing the old computer database, no efforts were made to extract data locked in the old database, thus all historical health data got locked on that old computer database in dBase IV.

In my study, I did not analyze the Access 97 computer database in detail because of the limitation of time. However, I interviewed users of the computer database at the regional and national levels to rate the database as “good” or “not good”. Immediately after its deployment, the database was reviewed on 2000, and the review study report suggests the Ministry of Health should solve the computer database disaster at the regional and national levels (MoH-TZ 2000).

In interviewing the MTUHA computer database users, the following were the main problems identified:

- ❑ The database was not completed. There is some data that is supposed to be recorded in the database but it is not possible.
- ❑ The vendor did not solve even a single bug of all errors/bugs reported in June 2001 in a 10-page report because the Ministry of Health had no money for fixing the bugs.
- ❑ No super-users, that is, users capable of performing some of the operations. Users need more training on how to use the software.

The MTUHAPROG bugs

These bugs reported here (Boehning 2001) relates to data entry. While users enter data into the database, the following happens:

- ❑ Currently the HMIS has changed the paper form from ‘Chloroquine’ to ‘Fansidar’ but the computer form is still presents ‘Chloroquine’. In the English version of the form sheet the data field is for: "Quarterly births", in the computer form the data field is for "Expected birth in the service area" and in the Kiswahili form sheet the data field is “children under one year”. That means the computer data field does not correspond to any form.
- ❑ Mismatch of indicator fields
Indicator 2 in the computer is Indicator 1 in the form sheet
Indicator 3 in the computer is Indicator 2 in the form sheet
Indicator 4 in the computer is Indicator 4 in the form sheet
Indicator 5 in the computer is Indicator 3 in the form sheet
Indicator 6 in the computer is Indicator 5 in the form sheet
Indicator 7 in the computer is Indicator 6 in the form sheet
Indicator 8 in the computer is Indicator 7 in the form sheet
Indicator 9 in the computer is Indicator 8 in the form sheet
Indicator 10 in the computer is Indicator 9 in the form sheet
- ❑ Section 10 is called in the computer "Actions planned to improve performance ...". This is section 11 in the form sheet.

Figure 6.5: MTUHAPROG reported bugs

- ❑ Users must fill in the ownership/services offered in the 'Reference data files' although the same questions are asked annually in form F005. The problem is that it is not possible to enter any data in the respective fields of F005 if the serviced offered are not filled in these Reference Files.
- ❑ If a health facility was offering a service and then closed, it is impossible to revive their services, because it is not possible, to delete the closing date in the Health Facility reference file. The implication of this is that it is not possibility to keep the history of closing and reopening of each Health Facility.
- ❑ It is not possible to review the entries of data entered through form F002. There is no report out of F002 available.
- ❑ In form F004, dates have to be entered as a text, this implies that is not possible to sort the data according to the date and users cannot perform operations related with dates.
- ❑ Users can enter YES or NO for out of stock but they would like to enter number of days out of stock.
- ❑ Form F005 does not allow the data entry of drug kits for other health facilities except "Local Government owned health facilities", while MTUHA policy requires private facilities to report.
- ❑ When pressing ENTER key after filling in the last field of form F005 part 8, all entries of part 8 are deleted.

Figure 6.6: MTUHAPROG bugs related to health facility data file.

MTUHA database with all these bugs, it is unlikely to have a smooth operation and hence to deliver the intended goal of the system.

6.3.8 Success of the HMIS

- ❑ A wide range of information, which covers different programs and services, is collected countrywide. Most of it is facility-based, but it does include some data from the community.
- ❑ Registers and records are generally located in all health facilities;
- ❑ If supervision is effective and/or local procedures for submission of reports are devised, timeliness and completeness of reporting could reach an acceptable level.
- ❑ The district-processing file is a well-developed tool for local evidence-based decision-making and performance monitoring, but it is not generally used for that purpose.
- ❑ Data collection tools are well developed.

6.4 Progress of HISP programme in Tanzania

A memorandum of understanding between the University of Dar-es-Salaam and University of Oslo in collaboration with the Ministry of Health was signed on 5th July 2002 that form a contractual agreement for HISP programme in Tanzania. At the time of writing, the HISP team has eight committee members where three are graduate students, two are lecturers at the University of Dar-es-Salaam, one is lecturer at the University of Oslo, and two are from the Ministry of Health in Tanzania. Communication with the group is via email communications because of the members being located in different countries. HISP Tanzania operates a website and mail list which include many health practitioners and is the means of discussion. Figure 6.7 presents information of the HISP Tanzania group on the Internet.

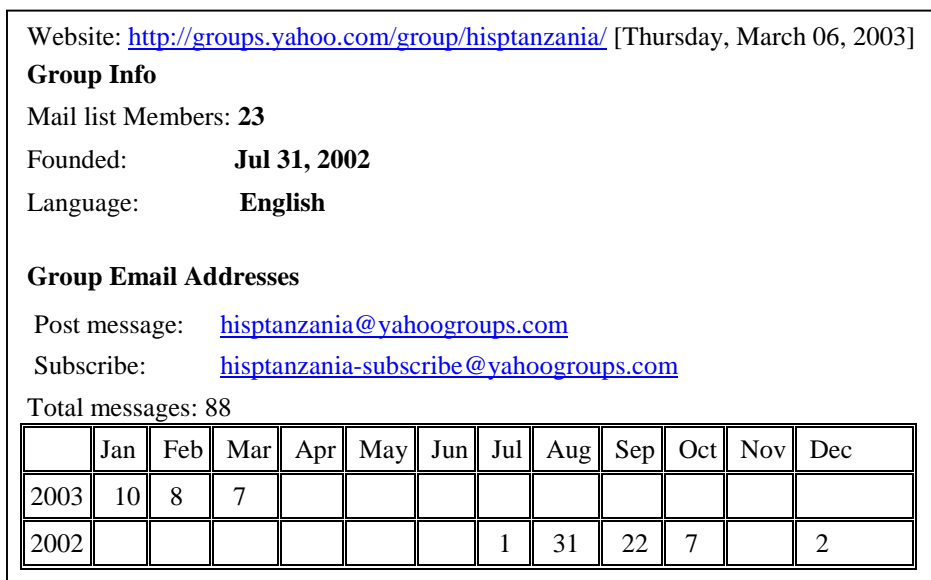

Figure 6.7: About HISP Tanzania

6.4.1 Prototyping the DHIS software

The DHIS prototyping discussion presented here is from one of the HISP sites in Tanzania, Bagamoyo district where I base my study.

Translating the DHIS software

The need for translating the DHIS is to adopt the environment where the software will operate in Tanzania. In the HMIS in Tanzania, all data elements are in English. However,

the data registers at the health facilities are all in Swahili language, the official language in Tanzania. The district medical office thus receives health data in Swahili, but they compile most of their reports in English with few reports in Swahili. Therefore, because the manual forms that are the source of the DHIS health data are in Swahili, the need for translating the software arises. It should also be noted that most of the health workers at the district level are not fluent in English, though they can read and write in English. The Swahili version will help them immensely.

My research was also aimed at demonstrating how the DHIS could be used in Tanzania. As part of this, I translated part of the software enough for demonstration purposes. Figure 6.8 presents the DHIS main screen in Swahili language.



Figure 6.8: DHIS main form in Swahili language

From Figure 6.8, the logo on the left below the screen is the University of Dar-es-Salaam logo and below right is the Tanzanian Map.

Populating the DHIS with health data

In performing the second activity, populating the DHIS with health data, I chose data for the year 2001 because it was possible to get all reports submitted for that year. Like in Mozambique, I had two options to populate the DHIS with health data: either to enter data directly from the completed forms or to extract data from MTUHA computer database. This time I opted to enter data from the manual forms, instead of developing an extraction transformation and loading (ETL) software to extract data from MTUHAPROG. I decided so because first, I did not have enough time to analyse the design of MTUHA database and that could have taken me one month or more. Second, I did not have any means of copying MTUHA database to my computer and I did not have any access to a computer where MTUHA database was installed, because while developing the ETL I needed to connect from both databases, DHIS and MTUHAPROG. Therefore, I collected all reports submitted at Bagamoyo office and started keying in the health data on the DHIS. Figure 6.9 presents the district hospital quarterly report data on the DHIS.

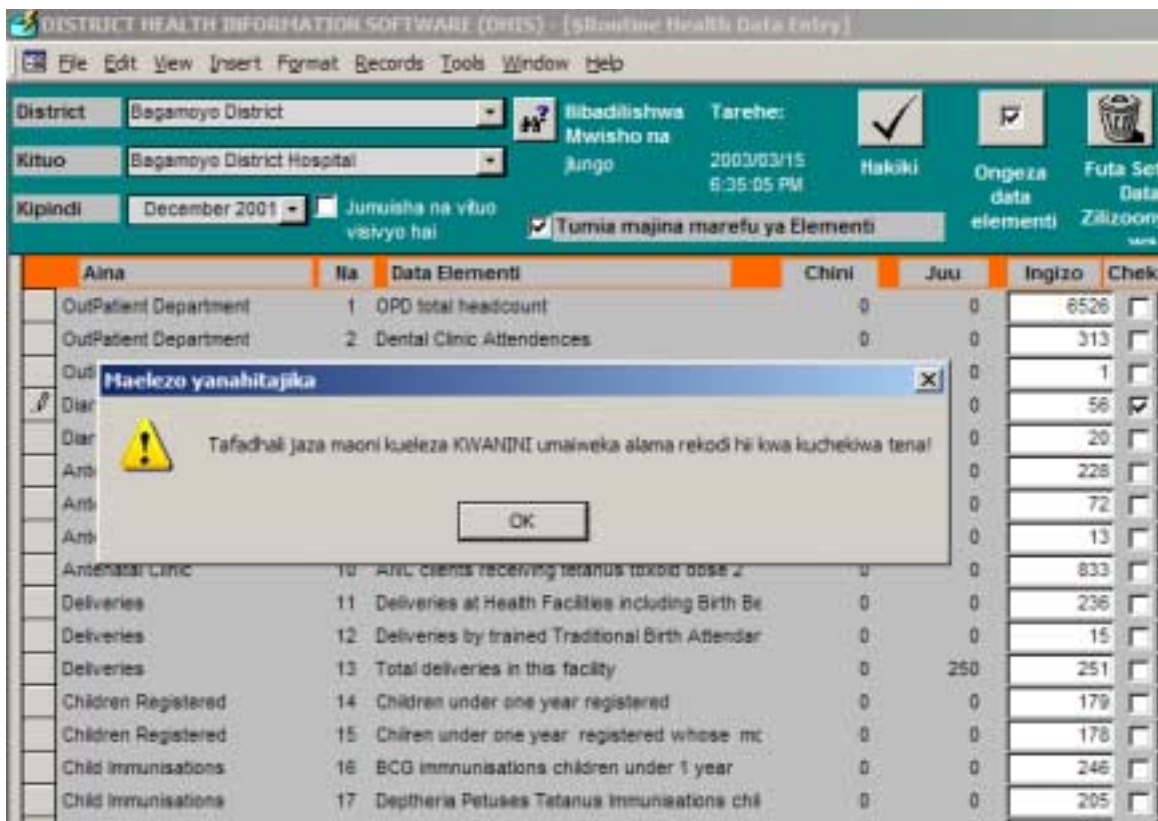

Figure 6.9: Quarterly report data from Bagamoyo district hospital on the DHIS

Demonstration of the DHIS functions

The first demonstration of the DHIS software was conducted in an organised workshop at Bagamoyo district on 26th July 2002, where I was the main facilitator, accompanied by the HISP team members. The participants were the district medical office staff, including the district medical officer and the district secretary of health. The presentation was video taped, because it not only presented the data entered in the DHIS but also demonstrated how users can enter data and generate standard reports. The most important part of that presentation is the discussion part, where users at Bagamoyo were asked to air their opinions about the software.



Photo 6.3: DHIS Training Workshop, Bagamoyo district medical office in Tanzania, 26 July 2002

The second presentation of the DHIS prototype took place on 30th July 2002, at the Library of the HMIS section of the Ministry of Health in Tanzania. The presentation was attended by internal HMIS staff at the Ministry of Health, as well as but also was attended by various organisations, being the most important ones the representatives of the donors of the Ministry of Health, namely USAID and DFID. Again, I was the facilitator of that presentation and discussion. The success of that presentation was that the Ministry of Health was officially approved the HISP programme in Tanzania. The Ministry of Health was further proposed that the memorandum of understanding that forms the contractual basis of HISP in Tanzania should be extended to include the Ministry of Health Officials and the Ministry of Home Affairs and Local Governance because the health facilities at the districts are under the Ministry of Home Affairs and

Local Governance. The HMIS also opted to use the DHIS for all district medical offices in Tanzania; this is because in 2002, the Ministry of Health distributed new computers to all district medical offices in Tanzania where there are basic requirements for computer to operate, especially electricity.



Photo 6.2: Participants of the first HISP presentation at the Ministry of Health in Tanzania (photographer: Lungo, J.H., Ministry of Health Library, 30 July 2002)

6.4.4 HISP Tanzania team weaknesses

The HISP team started at high speed but from the very beginning, in August 2002, misunderstanding amongst members started to appear. In that period, frustrating and abusive emails were posted on the email list until one member intervened to calm the members. All members except one never visited the pilot sites since July 26, until the time of writing. In addition, many members are reluctant to learn the software, DHIS, leaving only two members who are students to become the only super users that can train users in the pilot sites.

At the time of writing, the HISP Tanzania team has no official management such as coordinator, and the roles of each member are not yet defined. As a result, the team has no one to guide others or to define the activities, leading many members to keep quiet. There is a need to select a leader, and to recruit a full working personnel. However, the Ministry of Health officials, especially the head and senior managers of the HMIS are backing up HISP Tanzania efforts. This is because the HISP team consists of members from the trusted organisations, the University of Dar-es-Salaam, that ensures their availability and capability to sustain the software.

6.5 Chapter summary

The chapter presented the research fieldwork design and the case studies in Tanzania. I have collected data using interviews, group discussions, workshops, and analysis of documents collected in the field. The HISP project was officially inaugurated in July 2002, where my district case study was selected as a pilot site of the HISP project. In collaboration with HISP team members, we translated the DHIS into Swahili and demonstrated the HISP database, to the health workers at the pilot district and at the Ministry of Health. In all workshops aimed at demonstrating the DHIS, health workers argued about the DHIS software in particular, and the HISP approaches in general.

CHAPTER 7

EMPIRICAL FINDINGS AND DATA ANALYSIS

This chapter presents the empirical findings of the study. The combined data analysis of the study (section 7.1) is divided into different themes namely data generation; data management; data analysis, transmission, and reporting; data interpretation and use; feedback and supervision; training; organization and coordination; and operation of the computer database systems. Section 7.2 presents general findings and section 7.3 is a comparative analysis of the findings in the two countries. In this chapter, I will refer to the HMIS in Tanzania by its Swahili acronym, MTUHA and the HMIS in Mozambique by its Portuguese acronym, SIS. The corresponding computer databases will be referred as MTUHAPROG and SISPROG, respectively.

7.1 Combined analysis of the empirical findings

7.1.1 Data generation

Primary tool for data collection

Data collection tools at the health facilities are forms, book registers, and ledgers. These tools are designed and supplied by the national health information systems. However, some health facilities do design their own data collection tools because they want to collect their own data or the official data collection tools are not available, and would like to simplify their work, since the official registers are a bit complicated. In my study, I observed locally designed registers for recording distribution of condoms at one health centre in Tanzania. I asked the nurses why they have designed their own registers while the official registers are available in the health centre. One informant replied that,

“Although condoms are distributed freely, the health centre has to report how many condoms have been given to family planning clients. The official register requires that a client must be recorded her name and address. Our experience is that no family planning client would like to be recorded her name and thus if you stress to ask their names, no one will ask for a condom. Therefore, we put the condoms at the corner of the waiting room and clients used to take the condoms secretly. The nurses then have designed their forms to record how many condoms were released out, and at the end of the day they count the remaining ones to know how many have been collected” (Nurse Midwife, Chalinze Health Centre in Tanzania, 27 June 2002).

Those locally designed forms are not known at national levels and thus, the designers of the national registers do not take into account the creativity of the health workers at the health facilities. As a result, the Ministry of Health continues to print the same unfavourable forms and the health workers continue to waste time in designing their own forms.

Design of data registers

I investigated the design of registers through a combination of semi-structured interviews and observation of the forms. The questions were asked around two areas:

- ❑ Clarity of the data field on the forms, and
- ❑ Omissions, that is, any information that health facility is required to report but for which there are no place to record data on the available forms.

Clarity of the data fields on the forms

In Mozambique, an overlapping of the age groups was determined that leads to some confusion. For example, in 'Form B06', two data elements overlap the age groups: (1) 1as Consultas 0-11 meses and (2) 1as Consultas 0-4 Anos (the English translation is (1) 1st consultancy 0-11 months and (2) 1st consultancy 0-4 years). Note a six-month child falls in both groups; as a result, the health workers get confused.

Omissions

There is information that the health facilities have to report but the data registers were not designed to record that information. The current MTUHA data registers have nowhere to record:

- ❑ Vitamin A supplements for deliveries
- ❑ Tetanus vaccines for accidents victims
- ❑ BCG 2 in Form F202, which records information on immunization and Vitamin A supplementation for children.
- ❑ Treatments for syphilis

Although the health facilities are required to report to the district, there are no fields to record data for those data elements. One interviewee said:

“There is No place to record Tetanus vaccines for accidents victims but they want these data in the quarterly report...” (Nurse Assist, Chalinze Health Centre in Tanzania, 27 June 2002).

Availability of data registers

The interviews conducted with the health workers and the analysis of registers aimed to understand the situation of data registers at the health facilities. In the interviews, I asked the health workers to answer whether data registers are available “all the time” or “sometime”. All the interviewees (100%) answered “sometime”. To describe how they manage to collect data even if there are no data registers some interviewees explained that:

“They ask us not to use the same books used from previous years even if the books are not full. However we do use the same books until they bring us new books, we start to copy the entries from the old books to the new books” (Public Health Nurse grade “B”, Chalinze Health Centre in Tanzania, 27 June 2002).

“First of all we don’t have MTUHA Book 10 for this year! They didn’t bring us the book, we were using the same book of previous year and now the book is full so we do use loose papers to fill the reports” (Clinical Officer in Charge, Lugoba Health Centre in Tanzania, 27 June 2002).

“We don’t have MTUHA Book 10 yet, and it takes long time to order the book, so we are filling in the data in loose sheets. Also we don’t have form F203 for pregnancy mothers” (Nurse Midwife, Lugoba Health Centre in Tanzania, 27 June 2002).

Data collecting personnel

The research results indicate that at the health facilities there are no specific personnel employed for collecting health data; instead, they involve all health service providers (doctors, nurses, technician, and emergence workers). This involves completing forms and registers designed by the national health information system or those designed locally.

In district hospitals, there are hospital statistics officers who collate the data to form monthly and quarterly reports but at the dispensaries and health centres, anyone can be selected to collate the data. At the end of the month, the sum of the individual records recorded throughout the month is transcribed into another form to generate a monthly report. Thus, the same data are copied again to another form or book in summary form. In

Mozambique, the monthly report is transmitted to the district level because they do report monthly, while in Tanzania they report quarterly, so the individual monthly reports are then summed again to form quarterly reports.

Data source

In this theme of data generation, I investigated whether the data being reported was recorded at the community levels or at the health facilities. The research results show that most of the data being reported in both systems studied, MTUHA and SIS, were recorded at the health facilities. Data from the community level is not easily accessible. Through interviews, I found that MTUHA and SIS use volunteers to collect data at the villages. In Tanzania for example, each village has a village health worker (VHW) who is supposed to report deaths, births, and even outbreak of diseases to the nearby health facility. However, these VHWs are not employees of the MTUHA or the local government, and are just volunteers. Being volunteers, they do report on their convenient time and sometime they report incomplete information. Another group of health workers that collect community based data are Traditional Birth Attendants (TBAs). TBAs were found in Mozambique and Tanzania, and assist in deliveries in the villages. TBAs are supposed to report deliveries to the nearby health facility. In an interview with one informant at the Bagamoyo district medical office, he explained that,

“Some VHWs may see the District Health Officers in the bar, hotel, or during the supervision trips and report to them about certain deaths but they don’t know the exact age of the deceased and cause of the death. How can one register these records?” (Assistant Medical Officer, Bagamoyo District Medical Office in Tanzania, 26 June 2002).

The community health data collected are those related with outreach programmes, such as child immunization. However, community-based health data recorded through outreach programmes are transmitted to the higher levels as vertical programmes, without passing through the District Medical Office. For example, in the MTUHA, there are separate data registers labelled “outreach programmes”. In these special data registers, there are pages to be filled by TBA and immunization officer. That means the data are treated as separate from those captured from the health facilities.

Although MTUHA seems to be poor in accessing community based health data, one NGO in Tanzania, Adult Morbidity and Mortality Project (AMMP), demonstrates high performance on accessing community health data. At the time of writing AMMP is dealing with surveillance data like population data of the district; number of migrants; number of deaths and births in three sentinel sites in Tanzania. The same data are also recorded in the MTUHA. The MTUHA uses imputed data while that NGO uses headcount data. Imputed data are misleading, for example, while the population of Bagamoyo district in the year 2002 was estimated to be 246,754, the population census result of the year 2002 shows that the population of Bagamoyo district is 230,164, making a difference of 16,590.

AMMP uses key informants to get community based information. These key informants include: local leaders and eight community-development workers as enumerators for the census-update rounds, and three clinical officers act as verbal-autopsy (VA) supervisor. The system also has community based key informants, who report deaths to the VA supervisor on a regular basis. Stating how they motivate the key informants in the villages to capture data for deaths, the AMMP director said:

“... each key informant from a village or area has been given a “turubai” (canvas tarpaulin) so that the bereaved families from the community can borrow it for funeral gatherings during the mourning period. This has enabled key informants to get information on death that has occurred in his or her area and thus report it to the supervisor” (Director, Adult Morbidity and Mortality Project in Tanzania, 16 August 2002).

7.1.2 Data management

This theme presents the storage, processing, communicating, and sharing of health data at the health facility and district levels.

Data storage

Limited space for storing data registers was observed from the health facilities to the regional/provincial medical offices. Forms and register books are displayed on the floor, tables and uncovered shelves. Completed data registers tend to be destroyed and lost. The confidentiality of the information is also likely to be violated.



Photo 7.1: File store of one of the Regional Medical Offices in Tanzania (photographer: Lungo, J.H., 05 July 2002)

Data processing

The goal of data processing is to present information in a way that aids decision-making at all levels of the health information system. To prepare monthly, quarterly, and annual reports at the health facility and district levels, much of the data is manually copied from the primary data registries and forms transcribed daily to a number of forms. My study found that, to produce the reports, the data are transcribed from the original forms to other forms. For example, the following scenario describes how a district annual report (D005) is prepared at the district medical office (DMO) in Tanzania using an outpatient data as an example:

When a patient visits the health facility, the patient information is recorded in the outpatient register book. At the end of the month, the total of outpatient attendances is calculated and transcribed into the Health facility data book (MTUHA Book 2). At the end of the year, the total outpatient figure is transcribed from book 2 into Health facility annual report (F005) of MTUHA book 10. This annual report (F005) is submitted to the DMO's office. The DMO's office collects F005 from all health facilities in the district, sums the totals of outpatients, and transcribes them into District medical office annual report (D005) (Source: Document analysis results from Health Facility MTUHA Version 2.0 Guideline Manual, MoH-TZ 2002).

Inaccurate data

Errors often occur during the process of summing up and transcribing the entries from the primary data registers to generate monthly, quarterly, and annually reports. The basic problem found in my study is difficulties in performing the simple arithmetic without the aid of calculators. Inspection of the figures on the forms showed that sometimes the figures are not correct. I interviewed one nurse that deals with statistics of a health centre

who submitted a quarterly report at the Bagamoyo district, and rejected. The nurse showed the book and said,

“The summation of the drugs out of stock for the last three months were not correct”
(Public Health Nurse grade “B”, Chalenze Health Centre in Tanzania, 27 June 2002)..

In SIS in Mozambique, the guidelines to record data in January in every calendar year seems to confuse the data recorders while recording ‘1st consultancy’ (first attendance) and ‘follow-up consultancy’ (re-attendance). For example, to record clinics for children, a child is recorded as ‘1st consultancy’ in its first visit, and will be recorded as ‘follow-up consultancy’ in its subsequent visit. However, even if one re-attends the health facility in January, it will be recorded as ‘1st consultancy’ just because in January every attendance is first attendance. Figure 7.1 shows the comparison between ‘1st consultancies’ and ‘follow-up consultancies’ data captured from Bilene district, extracted from SISPROG and analysed using the DHIS.

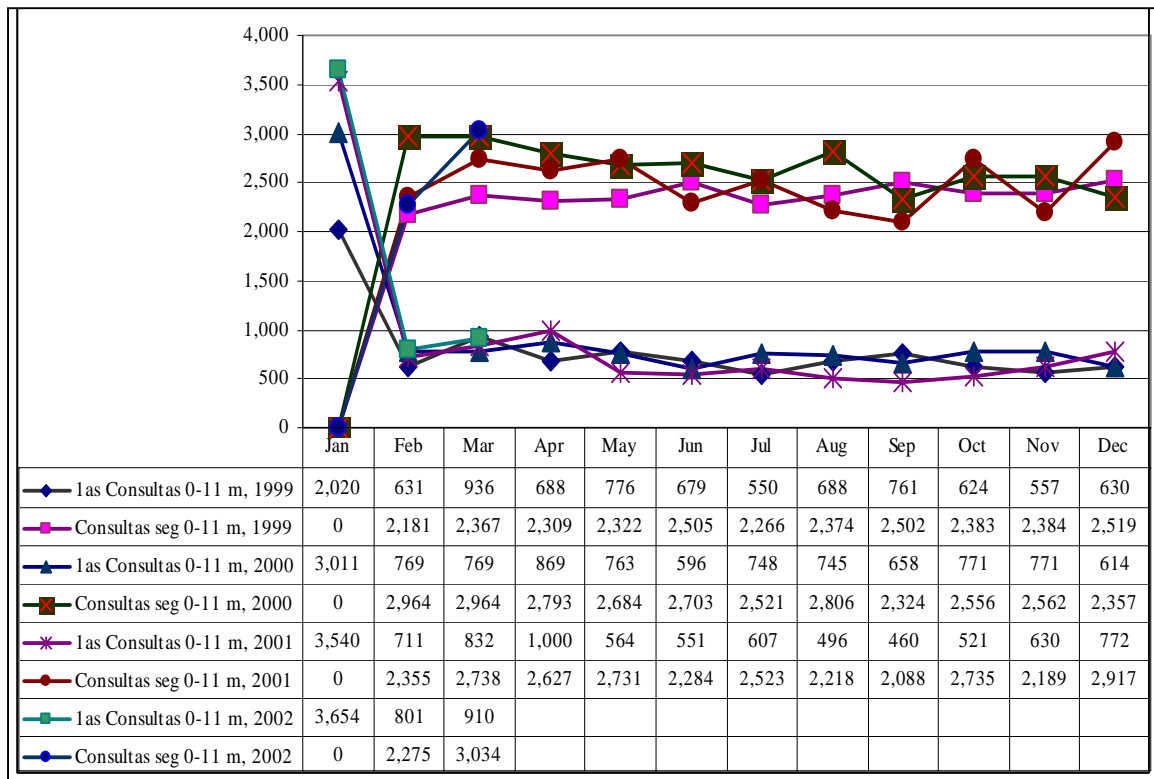

Figure 7.1: Comparison of attendance and re-attendance in SIS records for four years
(Source: SIS data from Bilene district analysed using the DHIS, March 2003).

In Figure 7.1, there is no data from April 2002 because that was the time the research was executed and data extracted to the DHIS.

I investigated the outpatients recording system in MTUHA in order to compare it with SIS. MTUHA guide her data recorders that “if a person is attending the health facility for the first time in the calendar year, mark the record with a star as a unique attendance” (MoH-TZ 2002, p.40). The total count of unique persons attending during the calendar year is used to estimate the utilization of a health facility. Utilization of a health facility by the population living in facility’s catchments area is a health facility indicator (MoH-TZ 2002). Table 7.1 is an example of recording outpatient given in MTUHA guideline manual.

Table 7.1: The MTUHA Outpatient Register

The Outpatient Register							
GENERAL SECTION							
Date page started _____							
*	Attend No.	Name	Village	Age	Sex	Diagnosis	Treatment
*	003	Yohanna Omari	Sambanga	52	M F	Malaria - uncomplicated	CQ tabs 4/4/2
	028	Yohanna Omari	Sambanga	52	M F	Hypertension	Propranolol tabs 80mg BD x 7/7
*	101	Samantha Chitambi	Urembo	1/12	M F	Otitis Media	Erythromycin syrup Q1D x 7/7
					M F	Diarrhea with dehydration	ORS
1	(2)	(3)	(4)	(5)	(6)	(7)	(8)

(Source: Adapted from MoH-TZ 2002, p.44)

From Table 7.1, if one feels in the “date page started” as “01 January 2002”, it is found that “1st consultancy” (the stared records in column 1) is equal to 2 and “follow-up consultancy” (the non-stared records in column 1) is equal to 1. Thus, there is little possibilities for “follow-up consultancy” to be zero in any month in the calendar year. However, at the district medical office, MTUHA does not have a data element for unique attendances “1st consultancy”, instead MTUHA has “Attendances” data element. Attendances are “a count of the disease episodes that the health facility has seen” (MoH-

TZ 2002, p.41), which is used to estimate workload in the outpatient clinics (see Appendix B.4 and Appendix B.5). The example given in Figure 7.1 is from children records. Usually a child is going back to the health facility twice or more in a month for a child is likely to be sick frequently.

Another analysis I did is with the data from Xai Xai City in Mozambique. I compared the ‘total deliveries’ with the sum of ‘live-births’ and ‘still-births’. The logic here is that, always the total deliveries should always be “equal or less” than total number of children signed out (live-births + still-births). Figure 7.2 presents the results of this analysis. Xai Xai city reported the number of deliveries to be bigger than the number of children signed out. I discussed Figure 7.2, using the mail list, and one discussant argued that the difference is due to errors in recording data, transcription, and collation (Simba 2003), see also Appendix E.1.

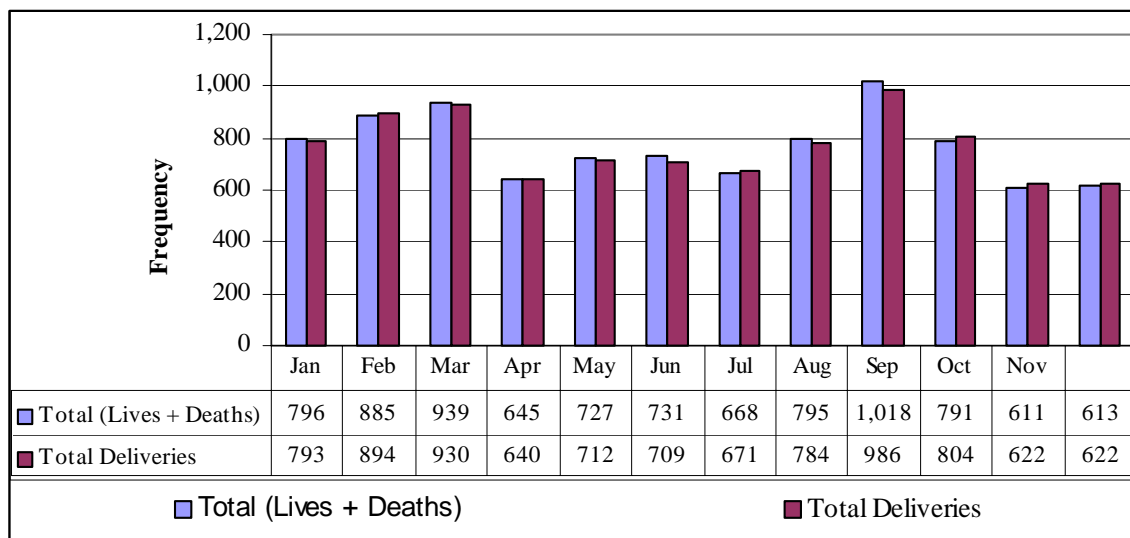

Figure 7.2: Xai Xai Maternity data from 1999 to 2001, note the differences in the month of February, July, October, November, and December (Source: SIS data from Xai Xai city maternity data from 1999 to 2001 analysed using the DHIS).

In another analysis, I have compared the total deliveries with the total number of children who received BCG first dose, in the districts. This comparison was performed based on the data extracted from the SISPROG. I assumed that even if there are many sources to

record deliveries at the health facilities, but this number of total deliveries is the sum of all deliveries recorded from the district. Since every new born is supposed to get the BCG first dose, the figures from these two data elements should be almost the same. Figure 7.3 shows that the number of BCG doses doubles total deliveries.

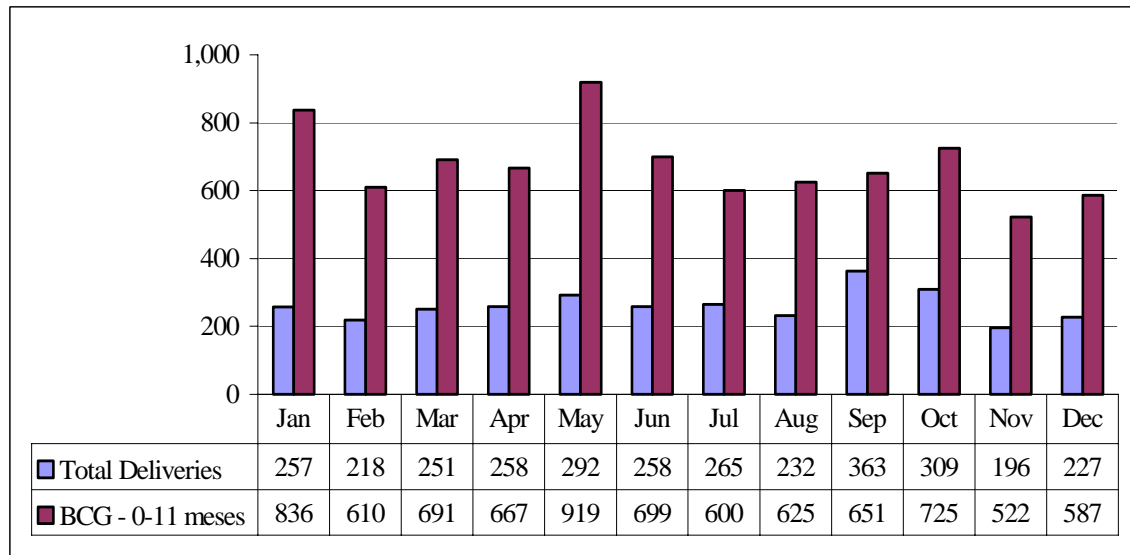

Figure 7.3: Comparison of total deliveries with BCG immunisation (Source: SIS 2001 data from Bilene district, analysed using the DHIS)

Through interviews, I understood that immunisation programmes in Mozambique have nothing to do with recording deliveries. While health facilities conduct Expanded Immunisation Programme through outreach programmes, they record immunisation only, and not the deliveries. That is to say, the deliveries reported here are those recorded at the health facilities only.

In comparing immunisation data given to the same age group of population, the figures are also not the same. Figure 7.4 shows the results. I discussed Figure 7.4 using an email list and one discussant argued that the number would be the same if and only if, all children get the jab. Not all do. The reason could be no vaccine, child born in a “non-vaccination” day, delivered in awkward hours, etc. See Appendix E.1.

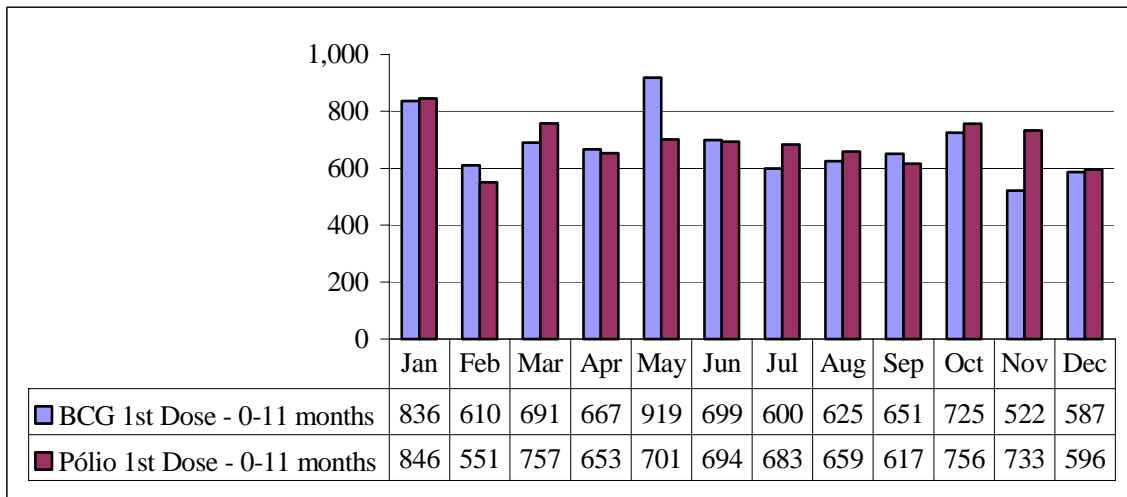

Figure 7.4: Comparison of BCG data with Polio data (Source: SIS 2001 data from Bilene district)

I used the DHIS to calculate some indicators after I entered Bagamoyo district health data in Tanzania. The results show that MTUHA is good in recording ANC, but the system does not know where deliveries take place. Figure 7.5 shows the result of calculating ANC Clients as percentage of all deliveries indicator.

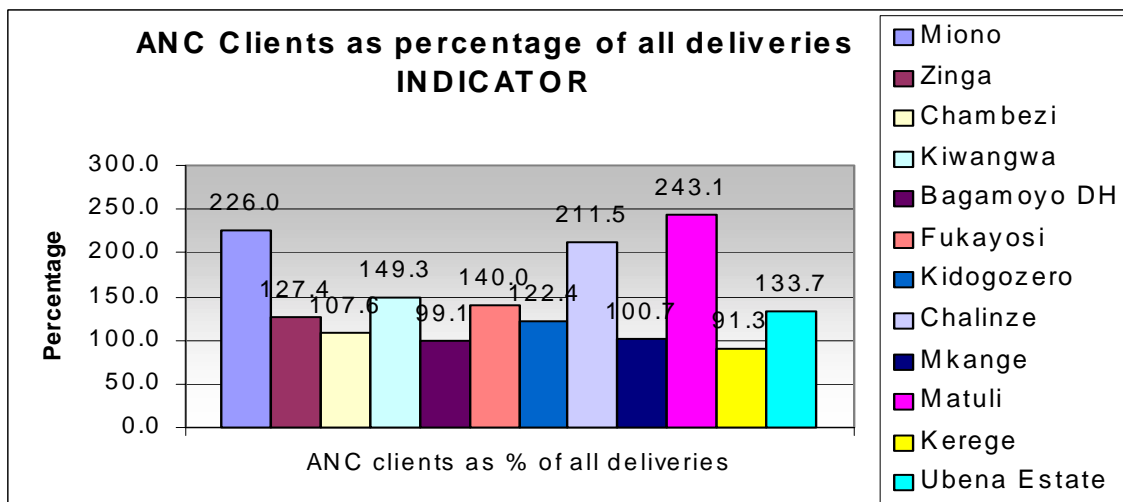

Figure 7.5: ANC clients as percentage of all deliveries (Source: MTUHA 2001 data from Bagamoyo district analysed using the DHIS)

From Figure 7.5, ANC clients as percentage of all deliveries indicator for Miono health centre is 226%, it means that the number of ANC clients registered in the whole year, divided by the number of deliveries in the whole year, multiplied by 100, equals 226. This implies that there were more ANC clients registered than the number of deliveries.

Bagamoyo hospital and Kerege dispensary have less than 100% of this indicator, which shows a direct correlation between number ANC clients and total deliveries. Through interviews, I further learned that many mothers wish to deliver at the health facility where they do attend their clinics. However, many of them deliver at home because of traditional beliefs, poor transport, poverty, unclear charges, mode of payment for deliveries at the health facilities, and bad reputation of the health workers at the health facilities.

7.1.3 Data analysis, transmission, and reporting

Data analysis

I interviewed health workers at the health facilities in Tanzania, asking, “Do you analyse routine health data at this health facility?” The responses were that many health workers at the health facilities said “yes”, they do analyse health data. However, based on observations, I found that what they call data analysis is the process of transcribing health data from primary data registers to the reporting books (Book No 10) and the health facility statistics book (Book No 2). For example, transcribing data from the primary data registries like outpatient registers to form the monthly totals and quarterly totals, is what is referred to as data analysis at the health facility.

Using a checklist of data analysis tools that are supposed to be available at the health facilities, I asked health workers to see whether they have those data analysis tools as recommended on the MTUHA implementation plan (MoH-TZ 1993). According to that implementation plan, every health facility is supplied with MTUHA Book 10 (which has aggregation forms/reports), calculators, and box files (MoH-TZ 1993). Table 7.3 presents information regarding the availability of data analysis tools at the health facilities. Most of the interviews (70%) at the health facilities responded ‘No’ when asked if data analysis tools are available.

Table 7.2: Availability of data analysis tools in health facilities

Type of Organisation		Availability of data analysis tools	
		Yes	No
Dispensary	Count		2
	% within Type of Organisation		100.0%
Health Centre	Count	1	5
	% within Type of Organisation	16.7%	83.3%
Hospital	Count	2	
	% within Type of Organisation	100.0%	
Total	Count	3	7
	% within Type of Organisation	30%	70%

(Source: questionnaire results, Fieldwork in Tanzania, June 2002)

However, the situation was quite different at the district, regional, and national medical offices. The higher levels seem to be well equipped. All (100%) interviewees responded ‘yes’ when asked if data analysis tools are available. These results are supported by observation results, where all districts visited in Mozambique and Tanzania, have computers, and some like Bagamoyo district have even a photocopy machine. However, the use of these data analysis tools (computers) at the districts is regarded as not fully utilised. For example, at Bagamoyo district, I observed one HIV/AIDS report printed from the computer with some mistakes of summing up the cases. The statistical officer said,

“You know, we are calculating these data manually then we give the secretary to type on the computer, because I don’t know how to use the computer (statistical officer, Bagamoyo District Medical Office in Tanzania, 05 August 2002).”

As described in the MTUHA implementation plan, every health facility has to have a medical recorder (MoH-TZ, 1993). A medical recorder is a trained health delivery personnel at the health facility that is capable to perform data aggregation tasks either by themselves or by supervising others in doing so. Table 7.4 shows the results of responses to the question “is a medical recorder available?”

Table 7.3: Availability of medical recorders in the health facilities

Type of Organisation		Is a medical recorder available?	
		Yes	No
Dispensary	Count		2
	% within Type of Organisation		100.0%
Health Centre	Count	1	5
	% within Type of Organisation	16.7%	83.3%
Hospital	Count	2	
	% within Type of Organisation	100.0%	
Total	Count	3	7
	% within Type of Organisation	30%	70%

(Source: questionnaire results, Fieldwork in Tanzania, June 2002)

Data transmission

Data transmission refers to the transfer of raw data from the health facilities to higher levels of a health management information system for the purpose of data processing. In my study, data transmission means the transfer of paper documents from health facilities to the district. District reports are generated, and then sent to the regional or provincial level where data are entered in the computer database system. From the region or province, data is sent to the national level in both paper documents and in computer files in diskettes.

In Tanzania, the district medical office staff are the ones who visit the health facilities to collect quarterly reports (usually in supervision trips or while distributing drug kits). In Mozambique, health facilities have to send reports to the district health offices. Both protocols of collecting data from the health facilities have advantages and disadvantages. When district officers collect data, they relieve the health workers at the facilities from sending the data, and it is a guaranteed solution because the district has more reliable transport facilities, like 4x4 cars, thus they can reach the facilities even during the rainy seasons. The drawback is that the district health officers cannot drive to all facilities in one day. Thus, the potential for data being reported late is high. In SIS, health facilities have to send the data to the district health offices. This ensures that all facilities can report in one day. The drawback is that many facilities have no reliable transport other than bicycles. During the rainy seasons, health workers cannot ride their bicycles to the district health offices, thus the process of transmitting data freezes for a while, until the

dry season. In SIS also, the facilities located very far from the health district usually report late or do not report frequently.

The type of data transformation in the two HISs studied, MTUHA and SIS, is determined as a vertical data transmission. There are four levels of vertical transformation of data namely: health facility level (lowest level), district level, region or province level, and national level (highest level). With vertical transmission, data are flowing from lower levels to the higher levels and vice versa. In my study, a high traffic of data is found from the lower levels to the higher levels, paper documents reporting routine health delivery services from the health facilities. The observed data flowing from the higher levels to the health facilities are the data registers and their guidelines for completing the data registries, description of the drug or vaccination kits, and supervision visits schedules. In one interviewee, the informants explained how the SIS gives feedback to the lower level.

“Sometime the provincial medical office do prepare a joint report for all data reported by the districts and distribute that report to the districts health directorate” (Director of Hospital and Obstetricians and Gynaecologist, José Macamo General Hospital in Maputo, Mozambique, 19 March 2002).

Data reporting

Under the MTUHA and the SIS systems, health facilities are required to send periodic reports to district offices, which report to the regional offices, and regional offices report to the national offices. During interviews at the health facilities in Tanzania, I asked to see evidence of the facility’s recent reports because the facilities usually retain copies of the reports. I asked to see copies of reports submitted in the year 2001. At the Bagamoyo district medical office, I asked to see the health facilities reports in the district processing file (DPF) and the record of health facilities reporting. Through observations on the Bagamoyo DPF and extracted data from the SISPROG, I gathered enough information to determine the level of total reporting of health data from the health facilities to the district offices.

Incomplete reporting

For one to get a picture of the real situation at the district, one should get the data from all health facilities. In the MTUHA implementation plan, all health facilities, whether

public, private, or religious owned, are supposed to report health data to the district medical office, using MTUHA registers (Ngatunga 2003). Bagamoyo district has 42 Health Facilities. The health facilities are reporting quarterly to the district. According to “health facility quarterly report data for the year 2001” obtained at Bagamoyo district medical office (DMO), 14/42 (33%) of the health facilities did not submit a single report at the DMO office and 19/42 (45%) of the health facilities did not submit their reports for the first quarter of the year 2001.

Brown *et al.* (1999) also describe the poor reporting of health data from the health facilities in a study of assessment of surveillance systems in Tanzania. “...only one quarter of the sites visited in this study have submitted complete reports for MTUHA in all four periods” (Brown *et al.* 1999, p.11).

Untimely reporting

Information gathered in Bagamoyo district medical office (DMO) for the year 2001 indicates that health facilities typically submit reports to the district office one to three months after they are due, and reporting from district to region office is often delayed further. Figure 7.6 presents records of health facilities submitted reports at the Bagamoyo district medical office. From Figure 7.6, while all health facilities are required to submit quarter one reports at the end of March or in April, all health facilities submitted quarter one reports in the month of May and some delayed until August.

Year 2001 Page

TABLE D1.2: RECORD OF HF REPORTING

HF Code	Staff List F001	Equip Inv F002	Phy Str Inv F003	Quarter 1 F004	Quarter 2 F004	Quarter 3 F004	Quarter 4 F004	Ann Rep F005	Rem/Main F006
001				7 MAY	19 Jul	18 OCT	21 JAN 02	21 JAN 02	
002	9 FEB	9 FEB	9 FEB	7 MAY	13 Jul	8 OCT	18 JAN 02	18 JAN 02	
003	12 FEB			22 MAY	15 Jul	17 OCT 01	17 JAN 02	17 JAN 02	
004	12 FEB			19 Jul	19 Jul	8 OCT	18 JAN 02	18 JAN 02	
005	8 FEB			22 MAY	13 Jul	17 OCT	17 JAN 02	17 JAN 02	
006				18 AUG	18 AUG				
007	13 Jul	13 Jul		13 Jul	13 Jul	8 OCT	15 JAN 02	15 JAN 02	
008	15 Jul	15 Jul		22 JUN	15 Jul	24 OCT	17 JAN 02	17 JAN 02	
009	1 MAR	1 MAR		16 JUN	13 Jul	15 OCT	17 JAN 02	17 JAN 02	
010	FEB	FEB		16 MAY	8 AUG	16 OCT 01	15 JAN 02	15 JAN 02	
011				16 MAY	13 AUG	18 OCT 01	21 JAN 02	21 JAN 02	
012				22 MAY	AUG	23 OCT 01	25 JAN 02		
013	26 MAR	26 MAR		18 AUG	18 AUG	25 OCT	16 JAN 02	16 JAN 02	
014	13 FEB	14 FEB		22 MAY	24 AUG	29 OCT	27 JAN 02	27 JAN 02	
015	13 FEB	13 FEB		22 MAY	13 Jul	24 OCT	16 JAN 02	16 JAN 02	
016	26 MAR	26 MAR		30 MAY	13 Jul	5 OCT	18 JAN 02	18 JAN 02	
017	9 FEB	9 FEB		22 MAY	13 Jul	25 OCT	18 JAN 02	18 JAN 02	
018	9 FEB	9 FEB		22 MAY	13 Jul	26 OCT	18 JAN 02	18 JAN 02	
019	20 MAR	20 MAR		7 MAY	17 AUG	26 OCT	18 JAN 02	18 JAN 02	
					31 MAR	6 NOV			

Figure 7.6: Record of Bagamoyo health facilities reporting (Source: Bagamoyo district processing file for 2001, Bagamoyo medical office)

Table 7.5 shows outstanding health facility reports of MTUHA data from Bgamoyo district analysed using the DHIS. The results indicate that many health facilities (69%) are not reporting in the first and second quarters of the year 2001 (the DHIS software puts “1” against a row of a health facility that did not report). Bagamoyo district has 42 health facilities, but 33% (13/42) health facilities have never sent a single report in the year 2001.

Table 7.4: Bagamoyo health facilities overview

Bagamoyo district: Health facilities overviews					
Health Facility Type	Government Owned Health Facility	Religious Owned Health Facility	Private Owned Health Facility	Institutional Owned Facility	Grand Total
District Hospital	1				1
Health Centre	4				4
Dispensary	24	4	5	4	36
Grand Total	29	4	5	4	42

Source: MTUHA 2001 data analysed using the DHIS, August 2002

Table 7.5: An outstanding health facility data (a DHIS analysis report)

Bagamoyo district: Outstanding report Year 2001 (Total health facilities = 42)						
S/No	Health Facilities	Mar-01	Jun-01	Sep-01	Dec-01	Grand Total
1	Hondogo	1	1			2
2	Matipwili			1	1	2
3	Mandera	1	1		1	3
4	Mbegani	1	1		1	3
5	Mlingotini	1	1		1	3
6	Msata	1	1	1		3
7	Yombo	1	1		1	3
8	Chalinze Tiegesean	1	1	1	1	4
9	Chalinze RC	1	1	1	1	4
10	Huruma Disp.	1	1	1	1	4
11	Kigongoni	1	1	1	1	4
12	Kiromo	1	1	1	1	4
13	Lugoba RC	1	1	1	1	4
14	Matipwili Railway	1	1	1	1	4
15	Mdaula Tiegesean	1	1	1	1	4
16	Msata Private	1	1	1	1	4
17	NAFCO Disp.	1	1	1	1	4
18	NARCO Disp.	1	1	1	1	4
19	St Elizabeth Disp.	1	1	1	1	4
20	Upendo Disp.	1	1	1	1	4
Total Missing Reports		19/42 = 45%	19/42 = 45%	15/42 = 35%	18/42 = 42%	71/168 = 42%

Source: MTUHA 2001 data analysed using the DHIS, August 2002

In Tanzania, most of the non-reporting health facilities are the private health facilities as shown (the shaded region) in Table 7.5, see Appendix E.2. In Mozambique, the trend of data reporting was observed that as a health facility becomes located very far from the district health directorate, the fewer the chances for that health facility to report, see Table 7.6.

Table 7.6: Trend of reporting as a district is located far from the city.

District	Total number of Health Facilities in the district	Total Health Facilities did not submit all reports	Non-reporting facilities as percentage of all facilities
Xai Xai City	6	1	16%
Xai Xai District	17	1	5%
Bilene District	13	2	15%
Chigubo District	6	6	100%

Source: SIS 2001 data analysed using the DHIS, April 2002

From Table 7.7, Chigubo district is a remotely located district where there is no electricity and most of the roads are not passable during the rainy seasons. On a map showing profiles of Mozambique territories (DINAGECA 1995), Chigubo district is classified as “3rd class” district, which means a poor district with very few socio-economic resources such as electricity, pipe water, telecommunications, etc, if any.

Data reporting coverage

To investigate whether MTUHA has managed to reach the target population, I calculated an indicator “registered cases as % of target population”. The idea here is that if the system has recorded cases as targeted population, this indicator will lead to 100%. For example, if the target population for ANC clients is 300, and the total number of ANC clients reported at the district is 300, then coverage will be 100%. Figure 7.7 shows the result of that indicator. According to Bagamoyo data for the year 2001, MTUHA reached 50% to 70% of the target population.

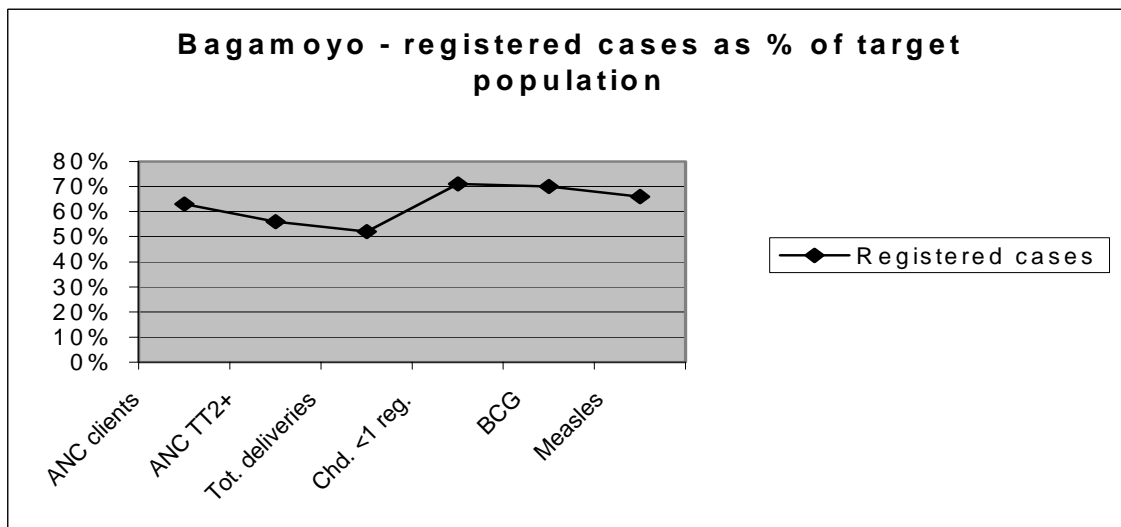

Figure 7.7: Bagamoyo registered cases as percentage of target population, year 2001

7.3.4 Data presentation

Data presentation is the means of displaying data to be accessible to other people. In this study, I identified that most of the health facilities, district, and regional/provincial medical offices present their data using line and bar charts. Those graphs and charts decorate many walls of offices and nurses' rooms.

Data presentation at the health facilities

I have seen hand-drawn graphs and charts in many health centres and the hospitals in Tanzania and Mozambique.

Data presentation at the district health offices

At the district medical offices, data are presented in graphs and charts on the walls. However, many of the graphs observed on this study are computer-generated outputs. Computer application software used to assist data presentation including word processor (I have seen only Microsoft Word) and spreadsheets (Microsoft Excel and Lotus Spreadsheets). The DHIS uses Microsoft Word and Microsoft Excel to present the data and graphs. However, there is no comprehensive use of the DHIS. At the time of writing, this study found no single official report generated using the DHIS in Mozambique.

Data presentation at the Regional or Provincial and National Offices

At these levels of the health information systems, most of the data presentation processes are computerised. They even produce reports with graphs and charts.



Photo 7.2: Analysis of health data using computers

7.1.4 Uses of health data

The idealised relationship between data, information, and decision-making (Sauerborn, 2000) is that,

“the collected data are transformed into information. Processing and analysing information with problem solving in mind leads to knowledge. The interpretation of this knowledge, then, is guided by subjective judgement, rather than by objective, scientific rigour” (Saueborn 2000, p.34).

The focus in this subsection is to illuminate the under-use and non-use of information in health information systems, because this is a major problem found in health information systems both in my own experience and in the published literatures (Campbell *et al.* 1996; Wilson *et al.* 2000). The study results show that health information is used in the following ways:

- to control epidemics;
- to plan and manage the health delivery services in the health facilities, including allocating the budget, allocating drugs, and consumables;
- to monitor and evaluate health facility performance; and

- to monitor and evaluate the health information system performance

In the next paragraphs, I present some examples demonstrating the use of health data in SIS and MTUHA systems.

While conducting analysis of documents at Bagamoyo district medical office, I found that the acknowledgement page of many documents produced by the District Council For Health Management Team (CHMT) acknowledge the work of the HMIS workers for providing basic data that enabled them to develop the annual health activities plans and budgets. One acknowledgement reads.

We wish to extent our thanks to health service providers from Rural and Urban Health facilities for providing data/information through the Health Management Information System (HMIS) which enabled us to prepare this plan (DED, 2002, p.i)

One of my informants at the Coast Regional Medical Office in Tanzania, said,

“We are using the information for management purposes. For example if we want to allocate a new clinical officer to a Health Centre, we can select a health unit and see the available staff list to see if there is a clinical officer or not” (Health Secretary, Coast Region Medical Office, 05 July 2002).

The Midwife officer, Lugoba Health Centre observed the trend of births in her health centre. She said that:

“If you look on the delivery register you will find that there is many cases of deliveries in the months of December and January. I used to attend up to four mothers per day while in the other months the number usually is one or sometime none. So in December and January, I usually look for many volunteers” (Nurse Midwife, Lugoba Health Centre in Tanzania, 27 June 2002).

An informant at Bagamoyo District Medical Office said,

“...I am not sure if the regional medical office uses all the data we are sending them, but with outbreak disease reports, they are acting on it. If you send them that cholera is disturbing somewhere, you will see more drugs for the disease and some extra vehicles are brought in ...” (Clinical Officer, Bagamoyo Medical Office in Tanzania, 25 June 2002).

However, there is significant under-use of the health data found in this study. There are basic data issues that the decision-maker should rely on the data generated, but this is not always the case. The distribution of “drugs kits” is the most crucial issue in all public

health services. A recent study by Adam (2001) to evaluate the quality of the health care services provided by health facilities in Tanzania, have shown that quality of health care services was perceived by most patients to be better in private and voluntary care facilities than in the public health facilities. “Deficiencies of drugs and working gears were far greater in the public health facilities than private and voluntary health facilities” (Adam 2001, p.72).

The study results indicate that there are limited relationship between the drug distributed and the data collected about how many days a particular drug has been out of stock in Tanzania. One Midwife Nurse at Chalinze Health Centre said,

“They pack the drug kits without using the data we are collecting, some time we cannot conduct children immunization because they bring different ration every month. Also the Kits distributions are not observing the immunization dates (calendar) they have their own dates of which are not constant” (Nurse Midwife, Chalinze Health Centre in Tanzania, 27 June 2002).

I also observed that the drug stores in the health facilities were full of medicines, yet the clinicians tell the patients that there are no drugs. At Lugoba Health Centre the drug store has many boxes of drugs. However, I was informed that the available drugs are for infrequent disease episodes. The Clinical Officer in Charge said,

“... drug distribution in our health centre does not correlate with the information we are giving them. For example: in “page 24 of MTUHA Book 2 - 2001”, we filled that co-trimoxazole susp was out of stock for 9 days every moth in average. However, they bring us the same amount every month. Another drug like BBE was not used at all or their consumption is very low, but they brought it every month” (Clinical Officer in Charge, Lugoba Health Cente in Tanzania, 27 June 2002).

At Chalinze Health Centre, the clinical officer in charge explained to me why it is not possible to control bilharzias in one public primary school that is located on the health centre’s catchments area where about 300 pupils were tested positive to bilharzias. He said that,

“...yes a study by a student from the University of Dar es Salaam made last month revealed that the school has 70% (210) of the 300 students affected by bilharzias. However, the KIT contains one tin of 100 tablets which can treats 30 pupils. When you treated these 30 pupils, they are contaminated again by the remaining untreated ones” (Clinical Officer in Charge, Chalinze Health Cente in Tanzania, 27 June 2002). He continued to say,

“A lot of medicines they brought in the Kits are not used. All these tins of medicine (he showed me) are not used simply because there is no diseases corresponding with these medicines. Although we do report all these problems, no one act on it” (Clinical Officer in Charge, Chalinze Health Cente in Tanzania, 27 June 2002).

At Bagamoyo district medical office, the Senior Clinical officer and Assistant Transport Officer attempted to explain why the distribution of drugs is not as what the facilities ask for. He said,

“The drugs KITS we are supplying to the health facilities are not enough. This is because the donors pack the KITS from abroad, so they give what they have and not what we want. Also determination of the catchments areas is a problem, we don’t have exact number of how many people are attending a certain health facility every year, we have projected figures” (Senior Clinical Officer and Assistant Transport Officer, Bagamoyo Medical Office in Tanzania, 26 June 2002).

7.1.5 Information system resources

The problems of under-use and non-use of information can sometimes be attributed to the accessibility of the health data and information generated. In my study, I attempted to investigate the accessibility of health data. One of the rationales for using computers in health information systems is to improve the accessibility for health data. Health data can be processed in large amounts quickly, published online through Internet, validated automatically, and stored in large quantities using computers. In this study, assessment of availability of computers in the health information system was performed in Tanzania.

Table 7.7: Availability of computers

Type of Organisation		Is a computer available for health data processing?	
		Yes	No
District Medical Office	Count	2	3
	% within Type of Organisation	40.0%	60.0%
Regional Medical Office	Count	2	
	% within Type of Organisation	100.0%	
Ministry of Health	Count	7	
	% within Type of Organisation	100.0%	
NGO	Count	8	
	% within Type of Organisation	100.0%	
Total	Count	19	3
	% within Type of Organisation	59.4%	37.5%

(Source: questionnaire results, Fieldwork in Tanzania, June 2002)

It should be noted that, all the four districts in Mozambique, were found to have computers, and those computers were used at least for secretarial purposes.

In the case study district in Tanzania, despite the availability of computers, there are informants who replied “no”, when asked if there is any computer for data processing. This was because computers were not brought by the MTUHA; it was individual and local effort that led to the acquisition of those computers. One informant said,

“The two computer you have seen in our computer laboratory, one belongs to the assistant district medical officer and the other one we purchased through basket funds five months ago. I have also my own Pentium III laptop” (District Medical Officer, Bagamoyo District Medical Office in Tanzania, 05 August 2002).

The Ministry of Health in Tanzania distributed computers for HIS data to all district medical offices in the year 2002. The Ministry of Health bought those computers and at the same time of this study, were distributing them to the districts. The Head of the HMIS section at the Ministry of Health said:

“...we found that it is good idea to capture health data at the district level in electronic format. To implement this idea, the Ministry has acquired 117 computers which are now being distributed to every District Medical officer’s office” (Head of HMIS Section, Ministry of Health in Tanzania, 15 August 2002).

Despite the availability of computers in the district medical offices, health data are transcribed and reported using the official registers that is paper-based. This paper-based system hinders accessibility of health data at the district because data stored in papers are likely to be misplaced if given to every one asking for it. Searching the data on the piled forms on the shelves and floors is a task that no one would like to carry out. Whenever someone from outside asks for the particular file, the health workers simply replied that the “data are confidential or not available”.

Table 7.8: Means of information dissemination

Type of Organisation		Means of disseminating data		
		Hardcopy	Softcopy	Both
Dispensary	Count	2		
	% within Type of Organisation	100.0%		
Health Centre	Count	6		
	% within Type of Organisation	100.0%		
Hospital	Count	2		
	% within Type of Organisation	100.0%		
DMO	Count	4	1	
	% within Type of Organisation	80.0%	20.0%	
RMO	Count		1	1
	% within Type of Organisation		50.0%	50.0%

Type of Organisation		Means of disseminating data		
		Hardcopy	Softcopy	Both
MoH	Count	4		3
	% within Type of Organisation	57.1%		42.9%
NGO	Count	7		1
	% within Type of Organisation	87.5%		12.5%
Total	Count	25	2	5
	% within Type of Organisation	78.1%	6.3%	15.6%

(Source: questionnaire results, Fieldwork in Tanzania, June – August 2002)

While asked whether it is easy to retrieve health data, health facility workers replied “yes”, but at the district and regional levels, they responded to “not easy”. It is relatively easy at the health facilities to retrieve data because the data was compiled in one Book (MTUHA BOOK 2). Eighty three percent (83.3%) of the health workers at the health centre agreed that data are easily accessible. At the district, the situation is different. The DPF file is composed of quarterly reports and annual reports from all health facilities in the district. To generate a report one has to retrieve all reports and start summing up. Although the region/province has health data in computer databases, they still face problems in accessing health data. One informant explained that,

“To send data to the Ministry is easy, we just export the data to a diskettes and send the diskettes, however to retrieve data for our own use is very difficult, because you must search in the piled reports from all districts and health facilities of our region. The computer database is of less help if you want to create a report” (Health Secretary, Coast regional Medical Office in Tanzania, 05 July 2002).

This suggests that things get harder as you go up the hierarch because of the amounts of data sources to deal with.

In the fieldwork I conducted in Mozambique at José Macamo General Hospital in March 2002 to understand data management processes, I found that the hospital used stick-counting method, calculators, and computer application software to analyse health data. The fieldwork results are summarised in Figure 7.8, and the report from that fieldwork was presented at the Faculty of Medicine, Eduardo Mondlane University on 25 March 2002.

From Figure 7.8 it is seen that, Doctors, Nurses, Technical Staff, and other health workers collect data by filling in a number of forms and register books. The statistics department collect these filled forms and stores them. To get statistics these data are being copied again to another form in a monthly, quarterly, or annual report. The report is edited in Microsoft word and Excel or in other computer programs and distributed to the Ministry of Health (MISAU), and donors. The reports are also used for internal control purposes.

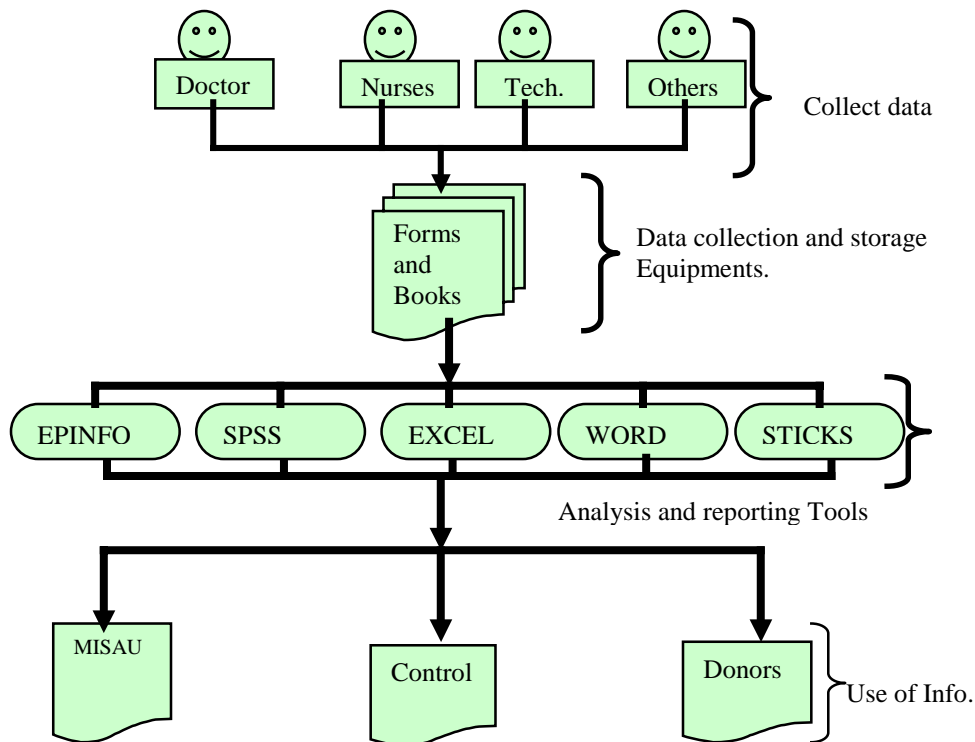

Figure 7.8: Health data processing at health facility level (Source: Fieldwork report, 25 March 2002)

7.1.5 Feedback and supervision

Regular supervision is an important part of an effective health information system. The MTUHA system procedures state that each health facility should receive a supervisory visit from district-or regional-level staff once every three month (MoH-TZ 1993). A study by Brown *et al.* (1999) indicates that, MTUHA systems do not provide systematic written feedback from higher levels to lower levels regarding surveillance data reported by lower levels. In their study, only 35% of the visited sites received feedback (Brown *et*

al., 1999). In my study, 90% of the health facilities receive feedback. The incentives of the supervision trips to health facilities make the health officers from the district office visit the health facilities regularly. While visiting the health facilities, they chat with the health workers, and that is what many informants referred to as feedback, Table 7.9.

Table 7.9: Feedback responses

Type of Organisation		Do you ever get feedback on results you send up?	
		Yes	No
Dispensary	Count	1	1
	% within Type of Organisation	50.0%	50.0%
Health Centre	Count	6	
	% within Type of Organisation	100.0%	
Hospital	Count	2	
	% within Type of Organisation	100.0%	
Total	Count	9	1
	% within Type of Organisation	90%	10%

(Source: questionnaire results, Fieldwork in Tanzania, June 2002)

In my study, I was not able to identify any occasions on which the district or regional officials had provided written feedback to reporting facilities. Even at the district-processing file in the MTUHA system, the feedback report pages were empty. Although one of the successes for MTUHA is the publications and distribution of Health Statistics Abstracts (MoH-TZ 2000), which are then sent to the regional offices each year, neither these nor any other Ministry of Health bulletin was observed at any of the health facilities I visited. However, supervision visits should be more exploited, as this is one of the opportunities for providing feedback to the health facilities.

7.1.6 Training

It is important that people who are responsible for managing health data have some formal training in collection, analysis and presenting the information. While interviewing health workers in Tanzania, I asked them whether they have ever received training on completing the data registers, 81% had been trained. A close investigation of MTUHA user training courses revealed that the training conducted in the visits, focus mostly on procedures for collecting data and completing the reporting forms. Brown *et al.*, discussed one problem related to MTUHA training approach that, “although high-level individuals were trained, lower level staff who do most of the routine work were not

trained and the higher level staff have not always passed their learning on to the others” (Borown *et al*, 1999, p.22). In this study, the prominent problem found is that MTUHA does not invite private health facilities in its training workshops and sometime forget to distribute data registers to the private facilities. The private health facilities complain that they are simply being ignored and thus they do not see why they have to report health data.

Users of the MTUHA and SIS computer databases demonstrated poor knowledge on how to use their databases. In Tanzania, MTUHA computer database users complained that they were taught how to enter data in the system but not how to generate reports from the database. They enter data in the system and send the data to the Ministry using diskettes but they use the reported manual forms to generate their own reports. In Mozambique, SIS computer database users face the same problem of poor training. Although SISPROG has a graphic utility, users print the raw data and re-type them in spreadsheets to generate graphs. No one interviewed in this study knew how to copy the graph generated by SIS to word processor and hence incorporate with texts.

7.1.7 Organisation and coordination of reported health data

The current health information systems in Tanzania and Mozambique are largely fragmented, which is a consequence of the partitioning of different health activities into separate vertical programmes, each with its own reporting system. Although efforts have been made to integrate vertical programmes into a comprehensive Primary Health Care approach, verticality of programmes is still a dominant characteristic of the health sector. The current structure of health information operations in Tanzania is characterised by several main systems: HMIS, Infectious Disease Week Ending (IDWE), Demographic Surveillance System (DSS), TB/Leprosy, HIV/AIDS and AFP. In addition, there are Traditional Healers, Village Health Workers (VHWs), and Traditional Birth Attendants (TBAs), who provide health delivery services. Some NGOs are also dealing with health data in agency like USAID with treating syphilis in ANC clients.

Fragmentation of the system imposes problems at the health facilities because a single individual, who may be responsible for multiple systems, finds it difficult to report in time because of duplicative data collection and reporting. This study found no officers, boards, or units with the responsibility for coordinating the different systems or activities at any level.

Although the HMIS in Tanzania made efforts to organise all data registers and reports in books and box files like the district processing file, still the data are found in different computer applications like word processor and spreadsheets. Storing multiple copies of the same data has implications for updating and for retrieving data.

In Mozambique, the SIS is also fragmented into several independent systems. While SISPROG is the main computer database system implemented in all provinces of Mozambique, other systems include BES, SIMP Pro, and spreadsheets in Lotus and Excel. The information systems are fragmented and there is very little integration between the systems. The only integration found is SIMP Pro software that extracts data from SIS computer database into spreadsheets but not the reverse case.

While working on extracting data from SISPROG, I had problems to obtain a complete list of health facilities in Gaza province. The list has been stored in SISPROG and on spreadsheets. Those lists are not similar and none of them is complete. They include missing, closed, new, and “ghost” facilities. A ghost unit is a unit, which is registered in the system but does not exist. Some of these ghost units were also reporting data. When I asked to get a complete list of health facilities in Gaza at provincial level it proved difficult. I had to work with the SIS statistical officer for two evenings to compile the list. However, on my visit to Manjacaze, Chibuto, and Bilene districts, the list of health facilities I had proved to be incorrect. Therefore, I had to update it based on the information found in the districts I visited.

7.1.8 Operation of computer databases

Organizations running legacy systems face problems because these systems were designed and implemented using both old hardware and obsolete system design

technologies. Technically, legacy systems were designed before object-oriented development was widely used in software development. “Rather than being organized as a set of interacting objects, the programs in these systems were usually structured as a collection of subroutines or functions” (Sommerville 2001, p.587).

Both databases, MTUHAPROG and SISPROG, were designed in such a way that data elements are stored as column head of the database data files, see Table 7.10 and Table 7.11. The data elements, which are dynamically changing, were tied in the program codes. This is a bad design because these data elements are subject to change at any time. When Vitamin A was implemented as a new data element in SIS and MTUHA, both databases suffered because there was nowhere to record the data for this newly introduced element. The MTUHAPROG vendor is known and still in Tanzania, but there is no money to pay for the requested changes. The SISPROG vendor was nowhere to be found. Another experienced example in MTUHA was the introduction of ‘Fansider’ as a first round of malaria after banning away ‘chloroquine’ for treating malaria. Because of technical limitations, the data element could not be recorded for one year, and thus led to other problems.

In general, the MTUHAPROG was perceived not good at all. Many (88%) informants in my study responded “not good” when asked to rate the performance of the MTUHAPROG as “good” or “not good”. In an interview with the system administrator at the HMIS section of the Ministry of Health in Tanzania, the informant explained that:

“We have some bugs in the current MTUHA database, this is normal to all systems, the problem is how to fix them. We do not have permission to reprogram the system. Every thin to be changed have to be done by the vendor, the ministry have no contract on fixing the bugs. So to fix a bug we have to set budget for it and it takes long time to be approved. Several times I have been in the vendor’s company but nothing have been done they just want money. We better go back to our old system where we were able to make changes on our own” (System Administrator, HMIS Section of the Ministry of Health in Tanzania, 15 June 2002).

In Table 7.10 and Table 7.11, the shaded region is the heading of the columns and is some of the SIS and the MTUHA data elements respectively.

system specification and or the source codes rather than the installation files only. Therefore, there was no straightforward way of specifying a new system, which is identical to the system that is in use (Sommerville 2001). I have spent one month just to understand the SISPROG and hence managed to extract the data. To do this, it required skills of systems analysis and design in relational database management systems.

Other problems with legacy databases have to do with compatibility issues. The incompatibility problem causes data loss. When a system is switched to another new database, it is not easy to export data to the new database so all the data in the old system remains locked in. In Tanzania for example, when the MTUHA decided in 2000 to use the current running Microsoft Access 97 database instead of the legacy database in dBase IV, no efforts were made to migrate the data in dBase IV to the Access 97 database.

7.2 General findings

In this section, I present additional research findings, which help to generate future research questions.

7.2.1 The roles of Traditional Healers and Traditional Birth Attendants in the HISs

As discussed in the situational analysis of MTUHA in the Tanzania case study (Chapter 6 Section 6.4.3), Traditional Practice is among of the authorities for administration and management of health services in Tanzania. Ten years ago, over 40,000 traditional healers have been identified; 3,000 herbs were analysed. Furthermore, there are “32,000 Traditional Birth Attendants (TBA’s) in the country, an estimate of four TBAs in each village among 8,000 villages” (MoH 1993, p.6).

As per the discussion of this study, the two HIS studied are poor in accessing community based health data. Although, MTUHA knows that traditional healers and TBAs are important health resources available at the community level (MoH-TZ 1993), the only data element that MTUHA records is “deliveries by TBA”. The traditional healers have their own reporting system to which MTUHA has no access. Figure 7.9 compares the “deliveries by TBA” and “deliveries at health facility” data elements.

From Figure 7.9, it is seen that, Bagamoyo Hospital and Chalinze Health Centre have captured more cases of deliveries than their counterpart TBAs. This is because the health facilities are located in the town, thus there is good quality of health services, and the people around that are more educated. However, the other health facilities are located in remote areas with limited health workers, and the community around those health facilities have a low education levels. Volunteer health workers, often below 25 years, are attending the mothers. In addition, the health facilities are located very far (5 kilometres) from the villages. As a result, many of them end up at the TBAs who are located within their villages and can be invited to attend one at home.

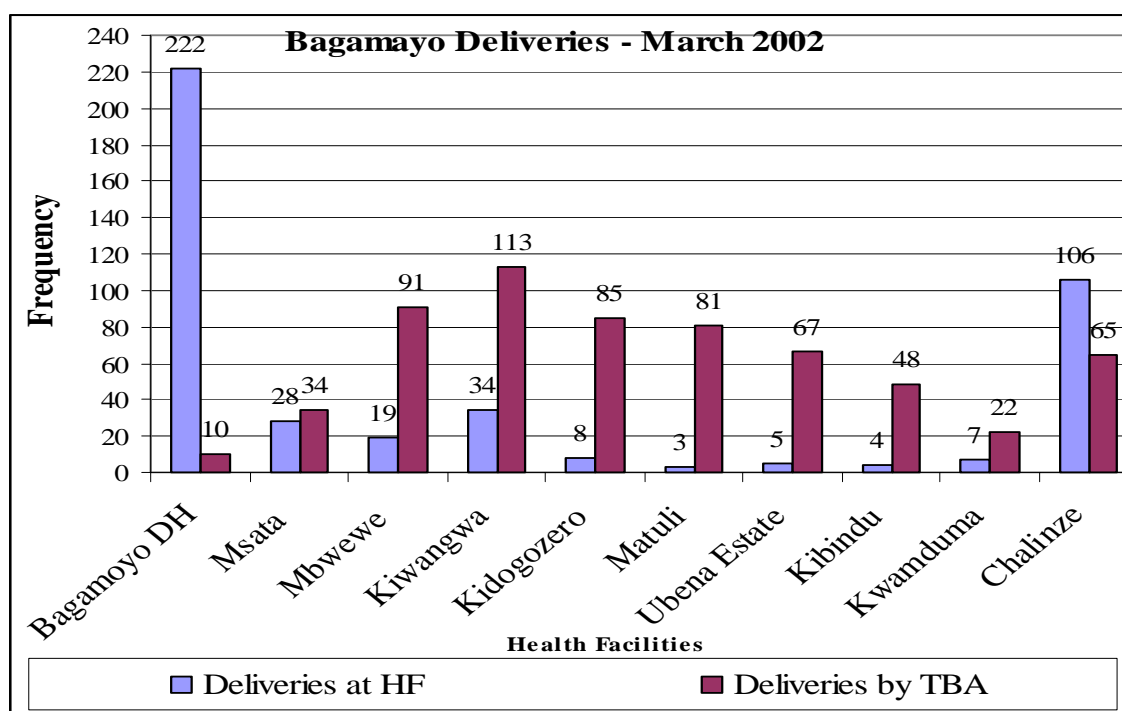

Figure 7.9: Comparison between Deliveries at HF and Deliveries by TBA (Source: MTUHA 2001 data from Bagamoyo district analysed using the DHIS)

In Mozambique, the SIS has a data element also for TBA deliveries, but this study found nothing in SIS concerning Traditional Healers. Conducting deliveries by TBAs is only one of the many roles of the TBAs and traditional healers play. There are many complications of deliveries that TBAs handle of which are not being recorded. Traditional healers are the known and the most trusted doctors in African traditions because they are close to the families. Many of the TBAs are also traditional healers,

because they do not attend the mothers with empty hands; they are conducting rituals and prayers, and they use different kinds of herbs. A recent study (Macome 2002) reports a “traditional blessing” conducted during the opening of the first Telecentre in Mozambique. Macome describes that traditional blessing as follows: “the traditional leaders informed the deceased leaders about the event and asked them to grant the initiative their protection in order to ensure its success” (Macome 2002, p.142). The traditional blessing reported here is a typical traditional healers activity but unfortunately, SIS does not know them. The question is, what can be done to incorporate health data from traditional healers.

7.2.2 Performance of the HMIS

In order to identify how far MTUHA has reached its target values, I analysed the health data by calculating the same indicators used by the district medical office. I have used the latest data for MTUHA (quarter one in 2002) that I had at the time of the study.

Table 7.12: Coverage Indicators for Bagamoyo district – March 2002

Indicator	Target Value	Registered Value	Threshold Value
Family Planning acceptance rate	15.00	7.85	10.00
Health Facility Reporting Rate	100.00	57.14	100.00
Attended deliveries as percentage of all births	60.00	52.25	40.00
ANC clients as percentage of all births	90.00	63.09	80.00
Children registered as percentage of all births	100.00	59.73	80.00
Children underweight	2.00	6.36	6.00
Percentage of children<1 year receiving Measles immunization	90.00	53.88	75.00
Percentage of Children<1 year receiving DPT 3	90.00	54.12	80.00

Source: MTUHA 2002 data from Bagamoyo district analysed using the DHIS, August 2002.

From Table 7.12, it is seen that only one indicator out of eight, Attended deliveries as percentage of all births, is above the threshold value. It can be argued that the contributions of the TBAs led to this indicator to be above its threshold value. This also indicates that the performance of the MTUHA is very low.

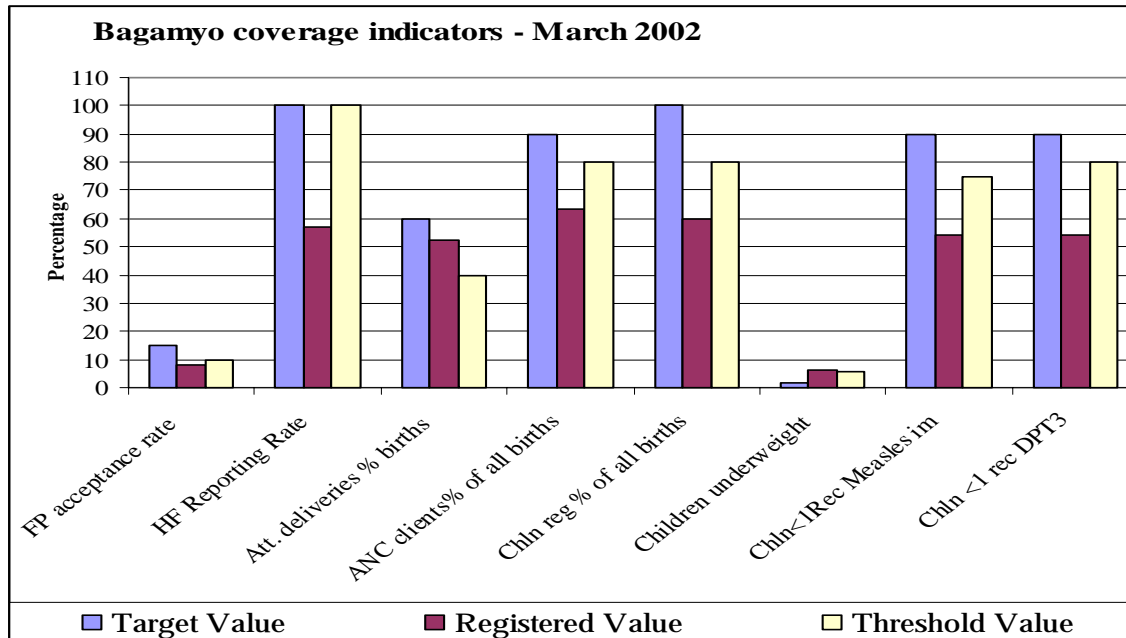

Figure 7.10: Coverage Indicators for Bagamoyo district – March 2002

7.2.3 ICT infrastructure

At the time of my study, I found that the ICT infrastructure in the MTUHA and the SIS is featured by desktop computers installed Microsoft Windows 95/98/2000/XP operating systems; and Microsoft Word and Excel 97/2000. I found only one computer with Lotus but also the same computer has Microsoft Word and Excel 97. In both systems, MTUHA and SIS, each computer connected to the Internet I found, had Microsoft Internet Explorer as the main browser, and Microsoft Outlook as the email management software. While SISPROG and BESPROG were developed in dBase III relational database management system, this study did not find the newer version of dBase than that where SISPROG was developed ten years ago, despite the fact that, in the market, there are new versions of dBase and even dBase for Windows. The patches of the SISPROG like SIMP Pro which improves the performance of the SISPROG and implements new features that are supposed to be in SISPROG, are developed in Microsoft based platforms. For example, SIMP Pro is developed using Microsoft Visual Basic 6.0 and it uses Microsoft Excel 2000 as its database.

In Tanzania, after MTUHA decided to relinquish its dBase IV national database, they switched to Microsoft Access 97 database system in the year 2000. At the time of this study, the Ministry of Health in Tanzania were distributing computers to all District Medical Offices in the country. Those computers are Pentium 4 processor, 1.6 GHz, 20 GB of hard disk, and 256 MB of RAM with Microsoft Excel, Word, and Access 2000 installed with Windows XP home edition operating system.

The incoming database management system, the DHIS, is developed in exclusive Microsoft platform. While developing the ETL software, a colleague of mine developed his ETL solution in Java platform and I, have developed my extraction, transformation and loading (ETL) in Microsoft platform. Finally we compared the advantages and disadvantages for developing the ETLs in the two different platforms (see Appendix D.5), and concluded that the Microsoft platform has more advantages than the Java platform.

7.3 Comparative analysis of Tanzania and Mozambique case studies

The empirical findings presented in this study, is blended into four common problems of the health information systems in Tanzania and Mozambique in particular, and in developing countries in general. The problems are (1) health information efforts seen as a burden to the health workers; (2) IT in the health sector is at its infant stage; (3) lack of information strategy, and (4) poverty.

7.3.1 Health information efforts seen as a burden to the health workers

The health workers perceive health information efforts as a burden to them. This is because of few health workers, unavailability of data registers, poor transport and communication infrastructures, no incentives to health workers for not receiving feedback on their efforts, existence of parallel systems, and non-use of the health data collected. As a result, untimely and incomplete reporting, incorrect data, and non-commitment to the whole process of reporting routine services delivery are dominating the health systems.

7.3.2 IT in the health sector is at its infant stage

To answer the questions asked by Wood-Harper and Bell (1990, p.23) presented in page 13 of this thesis, the study findings indicate poor information technology (IT) infrastructures in the two countries. For example, some districts are without electricity, no communication lines, and there exist old computers technologies like dBase III and Windows 95. In addition, the discussion of legacy information systems implies that there are few IT experts with limited computer skills to design and sustain reliable health information software. Thus, an extensive training support on IT technologies is essential, in order to sustain IT initiatives. While there are diverse computer technologies, the two health systems are monopolized by Microsoft. This suggests that the Microsoft-based incoming software is likely to be diffused easily in the existing IT installed base.

7.3.3 Lack of information strategy

As the research result reveals the availability of several parallel systems with no coordination unit. This finding suggests that there is a gap at the Ministries of Health. The Ministries of Health does not reach other health delivery practioners, such as Traditional Healers. This suggests the lack of information strategy in the health sectors to coordinate health information efforts.

7.3.4 Poverty

The vicious circle of the problems of health information systems can be traced to its origin to be poverty. Figure 7.11 presents the derived vicious circle of poverty in HIS.

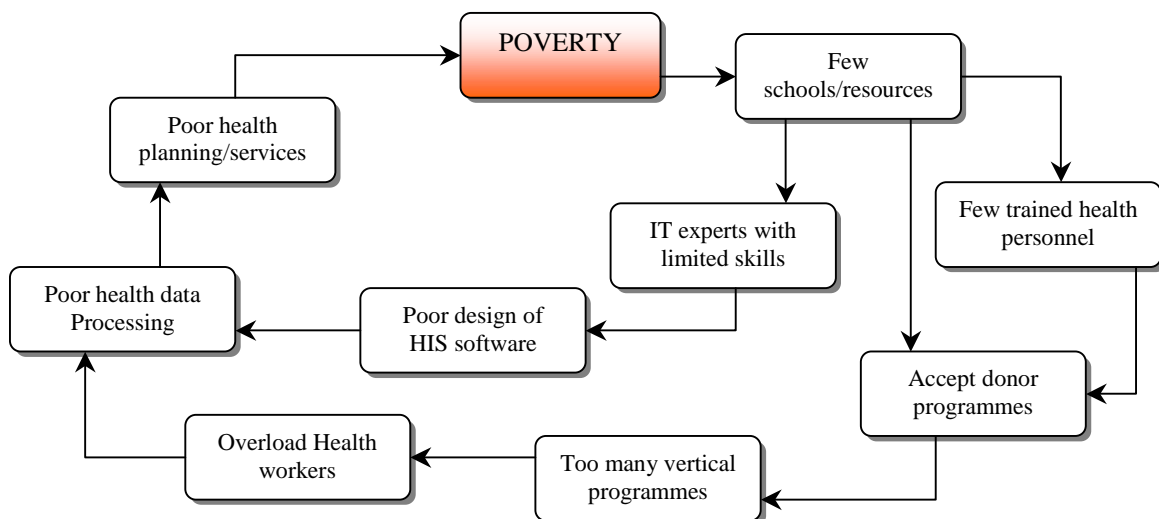

Figure 7.11: Vicious circle of poverty in HIS (source: Analysis of the study empirical findings, April 2003)

CHAPTER 8

KEY FINDINGS AND DISCUSSION

This chapter offers a discussion of the key empirical findings presented in Chapter 7. The Chapter responds to the research questions and objectives as presented in Chapter 1 by discussing the empirical findings in relation to theories from the literature, based on reflections of the research findings. First, I present an executive summary of the findings.

8.1 Executive summary of the findings

This study responds to the need of health information systems reform, particularly in developing countries. I approached the problem domain with two research questions: “*What are the problems of the current health information systems?*” and “*What are the benefits, challenges, and conditions for implementing a computer database at the district level of a health information system in order for it to be used as a health data analysis tool?*” To answer the research questions, I set three research objectives: to assess the performance of existing health information systems; to participate in prototyping a computer database, District Health Information Software (DHIS); and to assess the progress of the HISP project in Mozambique in order to identify learning gathered in HISP network that could guide the adoption of HISP in Tanzania and other developing countries.

In general, the empirical findings of this study present many problems of routine services reporting in the health information systems studied. The problems range from data generation; data management; data analysis, transmission, and reporting; data interpretation and use; feedback and supervision; training of the workforce; organisation and coordination of health delivery services; and the implementation of computer database systems.

At the start of the study, I assumed that computer databases were already installed at the regional, provincial, and national levels of the health information systems in Tanzania and Mozambique, and could be implemented at the district levels. The empirical findings

revealed serious problems that indicate that, those systems are themselves obstacles for reporting routine health delivery services. At the beginning of the study, the HISP project was seen as a “silver bullet” that could solve the problems of the health information systems in Mozambique, but the empirical findings again negate that assumption. The findings present the progress of HISP project in Mozambique to be slow. In this study data were migrated from the national computer database of the Ministry of Health in Mozambique to the HISP database, DHIS, a process expected to speedup the rollout of HISP database in many districts, but it was not the case, HISP faces major socio-political-technical challenges. Finally, the empirical findings present a lack of coherent health information policy at the Ministries of Health. As a result, there are many parallel independent systems involved in reporting health delivery services imposing burden to the health workers at the peripherals.

8.2 Problems of the current health information systems

The study indicates that the health planners are not able to use the vast amounts of the data generated. The main problems of the data generated by the health information systems found are as follows:

8.2.1 Information efforts seen as a burden

The research findings indicate that, many health facilities are understaffed. As a result, the majority of the health workers do feel being overloaded when asked to collect data. This is also supported by a report from the Bagamoyo District Medical Office which revealed 62% understaffing level at health centres, 33% at dispensaries and 14.2% at the district hospital (DED 2002). While the Health Management Information System in Tanzania (MTUHA) implementation plan insists on having health data recorder officers at each health facility (HoM-TZ 1993), the Bagamoyo district has no one. The understaffing problems were found also in the national health information system in Mozambique (SIS). Shortage of health workers is a bottleneck for reporting routine health delivery services because health providers are the ones recording health data. In this study, it was found that health workers feel more obliged to attend the patients than wasting their time recording data. Therefore, during the day, they attend the patients and

in the evening before they signing off, they fill in the data registers by memorising the activities they did during the day, so the accuracy of the figures depend on the vulnerability of the human memory. That is to say, an information effort is seen as burden to the health workers, and therefore is being given second priority, the first one being to attend the patients or clients.

8.2.2 Designs and availability of data registers

The study results show unavailability of data registers in some periods of the calendar year. Many health workers (93%) informed that the data registers are not available all the time. Health workers use loose papers until they get the registers, they start again to transfer all records from the loose locally designed registers to the official registers. This is cumbersome and is perceived again as a burden to the health workers. In addition, the process of copying data from one paper to another may increase the probability of recording wrong values. There is also some information the health facilities are supposed to report to the district health offices, but no data registers designed to capture those data. As a result, the health workers create their own registers. Also, some registers were designed without considering the context where the data will be recorded like the case of “condom distributions” at Chalinze Health Centre in Tanzania or the overlapping age groups in SIS forms presented in Chapter 7. All these are factors degrade the quality of the health data and confuse the health workers.

8.2.3 Lack of feedback and untimely reporting

The process of collating, analysing, transmitting, and presenting the health data is so tedious that by the time a report is prepared, the data are obsolete and decisions are often made without relying on any information input. Health planners and decision makers face deadlines and time constraints especially with many tasks on their hands due to shortage of staff. This study found health facilities reports reaching the district health office one to three months later after they are due and reporting to the region delayed further. There is also no written feedback found in this study. Delays in data transmission and lack of feedback is attributed to the presence of strong vertical programmes, few resources of data analysis, lack of reporting tools including the forms, poor transport and

communication infrastructure, and few health workers. Since health services supervisors and facilities health workers rarely receive feedback on the data reported to higher levels, they have little incentive to ensure the quality of the collected data and to comply with reporting requirements and deadlines.

The lack of complete reporting is also a serious problem found. The study results indicate many health facilities (45%) that do not send report to the district medical offices. In Tanzania, private health facilities are chronic for not reporting health data and in Mozambique, being located very far from the district health directorate is an excuse for many health facilities not to submit a health report. Since not all facilities do report health data, users of health data cannot get the picture of the real situation for health delivery services. The private health facilities in Tanzania justify their act of not reporting data by saying that MTUHA has forgotten them in that they receive no feedback and no invitations to attend training workshops.

There are authorities that are involved in the administration of health delivery services but the Ministries of Health have not established a policy regarding them, especially on how they can report their activities. Those authorities are Traditional Healers and Traditional Birth Attendants. Ignoring Traditional Healers and Traditional Birth Attendants also leads to incomplete reporting. In this study, the roles of TBAs have demonstrated to be strong in collecting health data for deliveries in remotely located villages (see Figure 7.9 in Chapter 7). However, TBAs officially are given a 2-week course before being registered, and the Village Executive Officer should record births if a TBA cannot read and write (Browl *et al.* 1999; MoH-TZ 1993). However, in practice, training a TBA for two weeks to record health data is impossible. It is also impossible for TBAs to ask Village Executive Officers (VEOs) to record births because TBAs are usually older experienced women while VEOs are usually young men. The two health information systems studied, MTUHA and SIS, demonstrated no established policy regarding traditional healers, thus excluding important information.

8.2.4 Absence of information strategy guidelines in the Ministry of Health

The national reporting systems in the two countries, Tanzania and Mozambique, have not been designed for a coordinated effort to address information needs of health planners and managers. Some donor agencies and national programmes within the Ministries of Health have developed their own specialised information systems. In the two information systems studied, there is no information officer with a detailed and comprehensive overview of the health information available. Many parallel systems are found. In Tanzania for example, there are several parallel systems (some national, some sentinel site based, some project or donor limited), which are not coordinated centrally by MTUHA. The same problems of running parallel systems were found in Mozambique. While the HISP project in Mozambique is aimed as an intervention effort to the current health information system problems, the way of operating now is like creating another parallel information system to SIS. In Gaza province, there are two computers, one for SIS database, and one for HISP database, the DHIS. At the districts where the DHIS is installed, users continue to use the paper forms for SIS and when HISP team members visit their pilot sites, users enter the same data to the DHIS.

While these separate systems could provide real information support for programmatic decisions, and the quality of the information generated tended to be better than that of the general information system (like the case of Adult Morbidity and Mortality Project in Tanzania), the net result is that routine health information systems become chaotic. Health workers are drowned in a multitude of reports to be completed and reported, and since the data are not cross-referenced among the different systems, health care providers and systems managers spend considerable amounts of time collecting redundant and overlapping data.

8.2.5 Legacy information systems

Both databases MTUHAPROG and SISPROG were designed in such a way that data elements are stored as column heads of the data files tables, that is, the program codes and the health data records are mixed together. This was a bad design because these data elements are subject to change at any time, and therefore with this database design, the

source codes must be changed frequently; a task that requires software-programming skills, which is rarely found amongst health workers.

In this study, application software was developed in order to extract health data from the SISPROG to the DHIS. The extraction of the health data was performed with the assumption that what is important is the data locked in the legacy information systems. Therefore, if it is possible to extract the data and load them onto another database, the Ministry of Health in Mozambique will rollout the DHIS to all provinces in the country. However, this study concludes that technical solutions are not enough to convince the use of a new system. In Mozambique, HISP has demonstrated to perform better and has gone as far as extracting all health data from SISPROG to DHIS. However, at the time of writing, no formal decision was put in place to rollout HISP in all provinces and even to mandate the HISP pilot districts to capture health data using the DHIS.

8.3 The benefits and challenges for implementing computer databases

As many health information systems reflect reform processes, the drive for the reform coincided with a revolution in information and communication technology (ICT). The computer has knocked on the doors even in the most reluctant countries, like the computer import ban of Tanzania (Kimaro and Spletstoesser 2000). Every one now a day discusses hardware, databases, Internet, emails, and other computer applications. With this state-of-the-art of technology combined with pressure from the computer industry, most health information systems restructuring is featured by computerisation to a certain degree. There is long list of benefits of computer databases in health information systems. In my study, the following benefits were experienced while participating in prototyping the DHIS database in Tanzania and Mozambique.

- Improving programme efficiency by processing and analysing large amounts of data quickly. This is demonstrated by the fact that after the SISPROG data were extracted and loaded to the DHIS, we generated standard reports and user defined reports. These were demonstrated to the SISPROG administrator of Gaza province the next day. This could not have been possible without the presence of a computer database, DHIS. In Tanzania, we entered data to the DHIS and made two demonstrations. The

indicators and totals that the district officers used to hunt for months were all automated in the DHIS.

- ❑ Producing a wide variety of outputs and feedback reports targeted for many levels of the health system from a single data set or by combined data sets.
- ❑ Reducing the duplication of work, which is typically seen in many hierarchical data collection systems. The calculation of indicators is good example. In MTUHA and SIS, the health facilities calculate indicators; the districts calculate the same indicators, and the regions or province and the national health offices also have the same indicators. All these need to be calculated at every level. With computer database like the DHIS, the calculations are automated.
- ❑ Improving the quality of data collection through automatic validation during data entry and automatic preparation of immediate feedback reports or errors for individual health facilities. For example, while entering data in DHIS, the database can alert users if they enter values that are out of the max. and min. values. These automatic validation rules reduce data errors caused by human mistakes.
- ❑ Improving analysis and information presentation to facilitate data interpretation and use for decision-making. Graphs, tables, and charts presented in this thesis were created using a computer database, the DHIS.

But introducing information technology in health information systems is not necessarily a “silver bullet” that solves the problems of health information systems. The legacy database systems presented in this thesis demonstrate how lack of appropriate computer database implementation strategy could create problems on reporting routine health delivery services. In my study, the challenge for implementing computer databases is not only technical issues but also the fact that health information systems are “social systems”. Taking the example of HISP project in Mozambique again:

The HISP team and I spent the whole months of April and May 2002 in Gaza province troubleshooting, configuring, and training the DHIS database. The database was running fine in some of the sites and the health workers at those sites have been trained at least the basics of starting the database and entering data. Somewhere in July 2002 two masters students went to the same sites for their own fieldwork but also trained the same users on how to use the DHIS. In September 2002, the HISP team members in collaboration with the Ministry of Health organised a mass DHIS

training workshop for all health workers in Gaza province where the same people at the districts where the DHIS is working participated. I visited those districts in November 2002 and found the only records in the DHIS are the ones I extracted from SISPROG and the one we entered while training them in April 2002. This is a great challenge for HISP in Mozambique.

I suppose that the district health directorate cannot decide on their own to start to capture health data using the DHIS without an order from the Ministry of Health. However, the Ministry of Health does not deny the project but does not participate in substance. Therefore, the most crucial challenge found is how to deal with the users to accept, act, and use the computer databases. In the following section, I present an attempt on how to overcome the challenges of implementing computer databases in health information systems.

8.4 Lessons from the HISP project network

This section also serves for identifying how the learning gathered in HISP network including from Mozambique can be sensitively applied to guide the adoption of HISP in Tanzania and other developing countries that reform their health information systems. I rely on the literature that describes the implementation of HISP project in South Africa and I compare it with the situation of HISP progress I experienced in Mozambique.

The DHIS software was developed from scratch using a prototyping approach in South Africa (Braa and C. Hedberg 2002). In referring the earlier discussion on a software prototype, a prototype should serve as a basis for discussion between users and developers on how to improve the system. As the DHIS continuous to revolve, the early versions of the DHIS introduced in Mozambique could be regarded as prototypes. However, it seems that the adaptations of the DHIS was introduced into Mozambique with minimal interaction with the users. This conclusion is reached because the HISP team members were observed in this study to spend short time in the pilot districts talking with users. For example, in April 2002, the HISP team members and I conducted two weeks fieldwork in the pilot district, where we visited Manjacaze and Chibuto districts once. Up to the time of writing, in April 2003, no one ever went back to those two districts. In a meeting with the Gaza provincial health director, the director insisted to

HISP team members to make a tentative schedule on when they would visit the province for DHIS training, so that their visit would not collide with other provincial activities. As a result, there is very low use of the DHIS and therefore the users were not able to identify problems or propose improvements on the software.

While HISP in South Africa keeps in touch with users through an email list (Visser 2003) and makes extensive onsite training, HISP Mozambique has no contact with the users except through telephones, which is very expensive for users to afford. Poor communication between HISP team members and their DHIS users could be attributed to the general poor communication infrastructures, for example the pilot sites are without email facilities. The HISP Mozambique email list does not include members from the pilot districts where the DHIS is installed. However, this study could not dig more to find out how much the HISP project has invested in communicating with users.

The training strategy of HISP Mozambique involves 40 to 60 people. The training covers the use of the SIS paper-based system, the basics of computer use, the HISP approach and the analysis of data using the DHIS. While the strategy of training many health workers at once could serve for political brokering like advertising the DHIS so that every one could become familiar with it, the success of that training strategy is questionable. Trainees may complete the course without the desirable skills because the classes are crowded with up to four trainees per computer. In addition, those trainees coming from districts without DHIS may end up forgetting their skills acquired in the training because they will not practice their skills.

The first pilot sites of HISP Mozambique are learning districts of the Eduardo Mondlane University (UEM) and “5 PhD students” with no single fulltime HISP member drive the HISP project. Through this study, I attribute the slow progress of HISP project with the selection of the pilot sites. This is because health workers perceive the HISP project as a mobile class for PhD students to learn how to analyse health data, especially when HISP team members take as excuse for not visiting the sites because they were busy with their studies. This assumption is supported by the increased momentum after HISP team

installed the DHIS in many districts in Gaza which are not UEM learning districts, like Chibuto, Manjacaze, Xai Xai, and Bilene.

The learned lesson is that users must be involved from the early stages in the selection of the pilot sites and software prototyping. Developers must spend considerable amount of time in the field in order to chat with users in such a way that users could identify some features in the software that were implemented as a result of their comments. The lack of full time HISP member in Mozambique to respond to the users complaints is also a bottleneck for the progress of HISP.

HISP project in Mozambique is not without success. The extraction of health data from SISPROG to the DHIS has enabled HISP Mozambique to use real sample data from the field while training on how to use the DHIS. After the extraction of health data from SISPROG, for the first time in health information system in Mozambique history, users have seen their data at district levels on a computer. In this study, it is argued that the project has strong and good project management, and there is little dispute between team members. This is a success, for many projects end up with disputes between project members and sometimes with donors if the project management does not account for the money received. However, there is a Swahili riddle saying that, “ukinyamaza ina maana unakubali”, which simply means if you keep quiet it means you accept. This is to encourage the HISP team members to speak up whenever they find their project does not going in the right direction. HISP team members have also compiled all data elements of the health information system in Mozambique and have initiated discussions on some confusing data elements, like the overlapping age problem presented in the earlier discussion and the January recording policy, see Figure 7.1 in Chapter 7.

The fact that HISP Mozambique has survived from its inception in 1998 to the moment of writing this thesis is also a success to the project.

CHAPTER 9

CONCLUSION

This chapter concludes the research efforts by presenting the research contributions, limitations, further research areas, and recommendations. To begin with, I present the research concluding remarks.

9.1 Concluding remarks

This study responds to the need of health information systems reform, particularly in developing countries by addressing many problems in the health information systems, and presenting the “how” to transform existing information systems into management support systems. The study has fulfilled both identification of the problems of the systems and taking actions on how to transform the systems to management systems, through assessing the existing systems and implementing a computer database system at the district levels. However, changing a system is a continuous process and takes time; one should not expect radical changes within one study.

According to the research results discussed in this thesis, it was revealed that the performances of the health information systems in Tanzania and Mozambique are not optimal enough to generate data that could support decision-making. The health data generated are of low quality because they are subjected to being aggregated, untimely reported, and not all health facilities submit their reports to the district health offices.

Based on the analysis and discussion of the empirical findings in the previous chapters, the following statements describe crucial factors that lead to efficiency problems of the health information systems:

- ❑ The health data generated are poor because health workers perceive information effort as a burden to them.
- ❑ The health data generated are poor because data collection tools (registers) are not available all the time in the health facilities.

- ❑ There is incomplete and untimely reporting of health data because of poor transport and communication infrastructures.
- ❑ The inaccurate of the health data is caused by existence of few health workers and lack of data analysis tools.
- ❑ The health systems are fragmented into several parallel vertical programmes because of the absence of information strategy guidelines in the Ministries of Health.
- ❑ It is impossible to capture some health data because of the inflexibility of the design of legacy information systems.

The study has shown that data locked in many legacy information systems can safely be extracted and migrated to new information systems. In addition, the study has demonstrated that, the District Health Information Software (DHIS) is a suitable software to be used as a substitute of the existing cumbersome computer database systems found in the health information systems especially in Tanzania and Mozambique.

9.2 The research contributions

This study contributes to the available knowledge in three dimensions: theoretical, methodological, and practical contributions.

9.2.1 Theoretical contributions

The literature review and empirical findings of this study, shed light on the domain of health information systems. The empirical findings presented a wide range of problems in health information systems, which is aimed to inform the health delivery practitioners and health planners what is going on in their health systems. The current problems of health information systems also presented in other works (Braa *et al.* 2001; Sauerborn and Lippeveld 2000) include incomplete, inaccurate, and untimely reporting of health data. Sauerborn and Lippeveld (2000) also pointed out that those efforts to reform health information systems were undertaken by national programme managers of vertically structured programmes. In this study, vertical programmes were found in both countries, Tanzania and Mozambique, thereby corroborating Sauerborn and Lippeveld observations. This study presented how the vertical programmes hinders health information efforts and recommend the Ministries of Health to integrated those vertical programmes.

As revealed in different works (Lippeveld and Sapirie 2000; McLaughlin 2001; Sandiford *et al.* 1992), introducing computer technologies in the health information system is not necessarily the silver bullet that solves the efficiency problems of HIS. This study reveals that bad design of the computer systems like the legacy information systems presented impose many problems. The contribution of this study is on how the users were involved in the introduction of a computer database in the health systems.

9.2.2 Methodological contribution

This study combined sociological research approach with software development approach, and was conducted by an IT professional. This contributes in that these professionals can be combined in one research to enhance the research results. The main methodological contribution of the research is that “action brings understanding”. The research methodology applied in this study, participatory action research, is a contribution in itself as this study demonstrates how action research can be implemented in actual practice of executing an information systems research. In addition to the qualitative data collection and analysis methods, other data collection and analysis methods like the use of photos, analyzing data using the DHIS, discussing the findings using emails, were invented and applied in the study.

In this study, I have populated the DHIS software with real data then demonstrating it to the users. Since traditional prototyping consists of making empty shells of user interfaces and demonstrating empty programs to users, the use of real data from the field while prototyping the DHIS in this study is a contribution to software prototyping that the use of real data from the field stimulates user participations.

9.2.3 Practical contribution

As an action research, practical contributions are contributions to the client systems (MTUHA, SIS, and HISP project in Tanzania and Mozambique), but also are regarded as general contributions to other similar systems. The contributions are termed as constructive contributions, because in this study something new and tangible has been realized. When I decided to take action by developing an extraction, transformation and loading (ETL) application software in order to copy health data from SISPROG to the

DHIS, I had never imagined how the resulting software would look like. It was also a great challenge to breakup software source codes developed ten years ago in old technologies which are no longer supported by any software development company in order to get data out. That made me to be proud that the ETL software is a solid contribution of this study in the software development practice and to the health information system and the HISP project in Mozambique.

In this study, I have also translated the DHIS software into Swahili language. Through the translation, we can learn that, health information systems have their own language quite different from direct English-Swahili dictionary. There are terms and terminologies been used in health information systems that are not in the English-Swahili dictionary that software developers could learn by involving users. The ways the software user interface changes after translating the captions of the commands from English to Swahili also gives a lesson that software developers should not rely on the dictionary only but they should be very selective while choosing corresponding words. Through this study, a Swahili version of the District Health Information Software (DHIS) is born.

The strategies proposed for implementing computer databases in health information system, make a contribution to information systems development. The role of prototyping and incremental approach of software development is seen as per this study as the most feasible approach for developing software for health information systems. This is because these approaches allow maximum users participation and collaboration a basis for breaking the political and bureaucratic walls of health information systems through demonstrating the software at early stages, negotiating while collaborating with users, and empowering local users to bargain from the higher authorities to give go ahead in order to implement new software.

9.3 Generalisation of the research findings

The purpose of this thesis was to investigate the problems of health information systems and the challenges to the process of introducing a computer database at the district level of the health information systems. The study was guided by three objectives: (1) to assess

the routine services reporting in the health information systems, (2) to prototype a computer database at the district level, and (3) to identify learning lessons from Health Information Systems Project (HISP) in Mozambique.

The study has adopted the health information systems assessment approach developed by World Health Organisation (WHO), which encourages the selection of subsystems and domains of health information systems for assessment because normally it is not possible to assess all health information subsystems in one study (Sapirie 2000). The WHO approach emphasizes that the assessment does not have to be nation wide, but could focus on one region. In this study, I have assessed the reporting of routine services delivery component of the HIS and covered one district in Tanzania but traced the reporting of health data from the health facilities to the region where the case study district belongs to, to the Ministry of Health and as far as to the external agencies dealing with health delivery services. In Mozambique, the study covered one province by involving four districts in that province.

In Tanzania, the DHIS software was prototyped in the case study district and at the health management information system (HMIS) section of the Ministry of Health; in Mozambique, the software was prototyped in the all case study districts and at the provincial health directorate of the case study province.

Interestingly, the empirical findings of the study fit in the same themes regardless where they were found. For example, while presenting the “incomplete reporting problems”, I used different examples from Tanzania and Mozambique to explain the magnitude of the problem. The analysis of the design of the computer databases implemented in the health information systems in the two countries demonstrated the same features. Finally, for the last 13 months I lived in Mozambique until the time of writing, have worked and been in touch with the HISP team member, a situation that has enabled me to learn their inner life and their roles towards the HISP project, in particular.

As presented in the derived “vicious circle of poverty in HIS ” (Figure 7.11 in Chapter 7), the source of efficiency problems of the health information systems is poor economic development. Since the case study sites are typical districts and are sufficient to be used as case study sites as per WHO guidelines, and since the findings converge with other works conducted in different case study sites and in different times, the empirical findings, discussions, and conclusions presented in this thesis is generalised that it represent the actual situation of the health information systems studied, and also to health information systems in comparable developing countries. However, the study was not without some limitations, which are presented in the next section.

9.4 Limitations of the research

9.4.1 Unaccomplished tasks

Time is the limit. In this study, there are some activities which were supposed to be part of the study but I was not able to accomplish them. It could have been good to test the extraction, transformation, and loading (ETL) software developed in Tanzania by migrating the health data from the MTUHAPROG to the DHIS but this was not done. The translation of the DHIS into Swahili was demonstrated to the users before all strings were translated.

In Mozambique, it could have been good extracting inventory control health data like number of beds in a hospital stored in Lotus and Excel spreadsheets to the DHIS, but that was not carried out. The SIMP Pro developer had asked to discuss how to integrate the DHIS with SIMP Pro, as on his own words,

“SIMP Pro is a temporary solution, I can see the DHIS as a permanent solution, so we need to sit and discuss how the two systems can be unified into one (SIMP Pro developer, Ministry of Health in Mozambique, 30 April 2002).

I did not meet the SIMP Pro developer again. Meeting the SIMP Pro developer could have provided another opportunity for extracting data from one system to another and reprogramming the DHIS to meet some features that are in SIMP Pro but missing in the DHIS.

9.4.2 Constraints

The research faced some constraints. In Mozambique, the main constraints were language and time. Time limited me not to do every thing I planned to do, but the language was a major constraint. The local language is Portuguese, a language I could not speak, read, and write at the first time of the fieldwork in Mozambique. I used to be a passive observer whenever the informants were not speaking English for I was afraid of interrupting the flow of the discussion by asking a colleague, “what is he or she saying”. However, I tried my best to communicate with the users, for example, by translating the interview questions into Portuguese (see Appendix A.1) and audio taping the interviews.

In Tanzania, the fieldwork allowance was paid late (end of July 2002) while the fieldwork started in the first week of June 2002. Because of lack of funds, I selected those health facilities, which are located in the main roads and in Bagamoyo town as my case study sites, so that I could reach them with minimum costs.

In one of the case study sites in Tanzania, I was not allowed to use a camera and an audio tape recorder. The restriction of not using a camera and audiotape frightened me even to take short notes. As a result, I wasted my time consulting them for two days to seek permission to conduct the research, and the number of estimated informants supposed to participate in this study suddenly dropped.

9.5 Further research areas

A further research area could be to study how the existing IT infrastructures, especially the Microsoft application software and Microsoft Windows operating systems, influence the institutionalization of new computer databases in health information systems.

Another interesting study could answer the question of how Traditional Healers and Traditional Birth Attendants contribute to the overall health delivery services and what activities of the traditional healers could be incorporated in the reporting of health delivery services and how.

The extraction, transformation, and loading software developed in this study could be expanded further to become a general solution or at least to extract data from other computer databases in the health information system in Mozambique like the SIMP Pro, various spreadsheets, and BESPROG to the DHIS; and to extract data from MTUHAPROG to the DHIS. The translation of the DHIS into Swahili language is not also over, the DHIS Swahili version is not extensively tested in the field and as new versions of the DHIS keep on being released, consequently the translation is a continuing activity.

9.6 Recommendations

In this section, I present recommendations to the health information systems studied and HISP teams in Tanzania and Mozambique by addressing problem issues.

9.6.1 Information efforts seen as a burden

Whenever possible, the health information systems should minimize the constraints to health workers by employing more staff and by integrating their fragmented systems so that health workers collect data for only one system. In addition, adequate technological support should be made available at the district level in order to assist data storage and analysis. Data collection tools should be available at the health facilities all the time, and the design of the data registers should be clear and should support local contexts.

9.6.2 Weak analysis of data and data reporting

The health information systems should implement a computer database at the district level to support storage, analysis, and presentation of health data. I would recommend the health information systems in Tanzania and Mozambique to adopt the District Health Information Software (DHIS), as this software has proved to have the capacity of being used as a health data analysis tool.

9.6.3 Feedback and training

Train and retrain health workers on the use of HMIS data registers and the software. If possible, curriculum of health training institutions should include data analysis and

presentation techniques. In addition, MTUHA should invite private health practitioners in its training workshops.

9.6.4 Legacy information Systems

Many reviews of health information systems have recommended scrapping away the legacy information systems (see e.g. MoH-TZ 2000). My recommendation is that should a health information system decide to scrap away the old computer systems, a deliberate effort should be taken to secure the data locked in these old systems. In addition, while acquiring new computer database systems, sustainability issues should be the main guiding principle for choosing and using new computer database systems.

9.6.5 Information strategy for the health sector

The Ministries of health have to decide on a health information strategy especially to put in place a unit that will be responsible for all health information efforts in their countries. The responsible unit should incorporate a blend of routine data collection, sentinel surveillance systems, periodic surveys, flows of information, strategy of feedback, and implementation of computer databases at all levels of the health systems.

9.6.6 Progress of the HISP projects

The HISP team members in Mozambique should increase their time to spend in the fields in order to collaborate with users. Not only will this create super-users of the DHIS in the pilot sites, but it will also empower users in bargaining to the higher authorities that they need a computer system in their working place while pointing directly to the DHIS. If possible, HISP Mozambique should employ a fulltime technical member whose responsibility will be to conduct onsite training and to respond to user queries.

The HISP Tanzania should learn from HISP Mozambique. Work longer in the field; employ a fulltime technical member; work together as one team in order to achieve tangible outputs.

BIBLIOGRAPHY

- Adam, N., 2001. *Assessment of quality of services in primary health care facilities in Moshi-rural district*. Thesis (MPH). University of Dar es Salaam.
- Agar, M.H., 1980. *The professional stranger: an informal introduction to ethnography*. New York: Academic Press.
- Ahmed, A.M., Urassa, D.P., Gherard, E., and Game, N.Y., 1996. Patients perception of public, voluntary and private dispensaries in rural areas of Tanzania. *East Africa medical journal*, 73 (6), 370-374.
- Amonoo-Lartson, R., Ebrahim, G.J., Lovel, H.J., and Ranken, J.P., 1984. *District health care: challenges for planning, organisation, and evaluation in developing countries*. London: Macmillan.
- Anderson, J.G., and Aydin, C.E., 1994. Theoretical perspectives and methodologies for the evaluation of health care information systems. In: J.G. Anderson, C.E. Aydin, and S.J. Jay, eds. *Evaluating health care information systems: methods and applications*. Thousand oaks, CA: Sage, 1-29.
- Anderson, J.G., Aydin, C.E., and Jay, S.J., eds., 1994. *Evaluating health care information systems: methods and applications*. Thousand oaks, CA: Sage.
- Auxila, P. and Rohde, J., 1988. Microcomputers as a means to introduce effective management procedures in primary health care: the Haiti experience. In: Wilson, R., ed. *Management information system and microcomputers in primary health care*. Geneva: Aga Khan Foundation, 53-58.
- Avison, D. and Myers, M.D., eds., 2002. *Qualitative research in information systems*. London: Sage.
- Bansler, J., 1989. System development research in Scandinavia: three theoretical schools. *Scandinavian journal of information systems*, 1, 3-20.
- Baskerville, R.L., 1999. Investigating information systems with action research. *Communications of the association for information systems* [online], 2 (9). Available from: http://www.cis.gsu.edu/~rbaskerv/CAIS_2_9/CAIS_2_9.html , [Accessed 23 December 2002].
- Baskerville, R.L. and Wood-Harper, A.T., 2002. A critical perspective on action research as a method for information systems research. In: D. Avison, and M.D. Myers, eds. *Qualitative research in information systems*. London: Sage, 129-145.
- Bhatnagar, S.C. and Bjørn-Andersen, N. eds., 1990. *Information technology in developing countries*. North-Holland: Elsevier Science Publishers B.V. and IFIP.

- Bhatnagar, S.C., 2000. Social implications for information and communication technologies in developing countries: lessons from Asian success stories. *Electronic journal of information systems in developing countries*, 1 (4), 1-10.
- Bjørn-Andersen, N. and Hedberg, B.L.T., 1977. Designing information systems in an organisational perspective. *TIMS studies in the management science*, 5, 125-142.
- Bjørn-Andersen, N., Mohan, L., and Belardo, S., 1990. A contingency approach to managing information technology in developing nations: benefiting from lessons learned in developed nations. In: S.C. Bhatnagar, and N. Bjørn-Andersen, eds. *Information technology in developing countries*. North-Holland: Elsevier Science Publishers B.V. and IFIP, 15 – 22.
- Blum, F., 1955. Action research: a scientific approach? *Philosophy of science*, 1 (22), 1-7.
- Boehm, B.W. and Gray, T.E., 1984. Prototyping versus specifying: a multi-project experiment. *IEEE Transactions on software engineering*, SE-10 (3), 290-303.
- Boehning, F., 2002. *Some of the errors/mistakes of the MTUHA version 2.2 of 19/6/2001*. Tanga: Tanga Regional Medical Office, Tanzania.
- Boland, R.J., 1978. The process and product of system design. *Management science*, 24, 887-898.
- Bonoma, T.V., 1985. Case research in marketing: opportunities, problems, and a process. *Journal of marketing research*, 22, 199-208.
- Braa, J., Heywood, A. and Hedberg, C., 1999. The South African experience: a model for developing 'bottom-up' large scale district health and management information system. In: *The HELINA – 1999 conference*, Harare, Zimbabwe November-December 1999.
- Braa, J., Macome, E., Da Costa, J.L., Mavimbe, J.C., Nhampossa, J.L., José, B., Manave, A., and Sitói, A., 2001. A study of the actual and potential usage of information and communication technology at district and provincial levels in Mozambique with a focus on the health sector. *Electronic journal of information systems in developing countries* [online], 5 (2). Available from: <http://www.is.cityu.edu.hk/ejisdc/vol5.htm> [Accessed 17 September 2002].
- Braa, J. and Hedberg, C., 2002. The struggle for district-based health information systems in South Africa. *The information society*, 18 (2), 113-128.
- Braa, J., Sahay, S., and Monteiro, E., 2003. Networks of action: sustainable health information systems across developing countries. Submission for special issue on action research, *Management information systems quarterly*, forthcoming.

- Brown, W., Nsubuga, P., and Eseko, N., 1999. *Activity report No. 62: assessment of infectious disease surveillance systems in Tanzania*. Washington, DC: United States Agency for International Development.
- Campbell, B., Adjei, S., and Heywood, A., 1996. *From data to decision making in health: the evolutionary of a health management information system*. Amsterdam: Royal Tropical Institute.
- Checkland, P. and Scholes, J., 1990. *Soft systems methodology in action*. Chichester, UK: John Wiley.
- Checkland, P. and Holwell, S., 1998 *Information, systems and information systems: making sense of the field*. Chichester, UK: John Wiley.
- Chilundo, B. and Sahay, S., 2002. Clinical laboratory information systems in Mozambique: the great challenge. In: S. Krishna and S. Madon, eds. *Proceedings of the IFI WG9.4 conference on information and communication technologies and development: new opportunities, perspectives, and challenges*, Bangalore 29-31 May 2002. Bangalore: Indian Institute of Management, Bangalore (IIMB), 477-487.
- Chislenko, A., 1995. *Legacy systems and functional cyborgization of humans* [online]. Available from: <http://www.lucifer.com/~sasha/articles/Cyborgs.html>, [Accessed 08 January 2003].
- Dawson, C.W., 2000. *The essence of computing projects: a student's guide*. Essex, UK: Prentice Hall.
- Day, C., Boulle, A., Shongwe, B., and Ramduny, V., 1998. *Health link evaluation: a technical report*. Durban, South Africa: Health Systems Trust.
- DED, 2001. *Bagamoyo district council health plan for the year 2002*. Bagamoyo, Tanzania: District Executive Director's office.
- DED, 2002. *Bagamoyo district council health plan for the year 2003*. Bagamoyo, Tanzania: District Executive Director's office.
- Denzin, N.K. and Lincoln, Y.S., 1994. *Handbook of qualitative research*. Thousand Oaks, CA: Sage.
- Dick, B., 2002. *Thesis resource paper: you want to do an action research thesis?* [online]. Available from: <http://www.scu.edu.au/schools/gcm/ar/art/arthesis.html>, [Accessed 27 December 2002].
- DINAGECA, 1995. *Mapa de Moçambique: divisão territorial, 1:2,000,000*. Maputo: Direcção Nacional de Geografia e Cadastro.

- Downe-Wambolt, B., 1992. Content analysis: methods, applications, and issues. *Health care for women international*, 13, 313-321.
- Elden, M. and Chisholm, R.F., 1993. Emerging varieties of action research: introduction to the special issues. *Journal of human relations*, 46 (2), 121-142.
- Gallis, H.E. and Kasbo, J.P., 2002. Walking away from the PDA: a contextual study of medical student's use of mobile terminals and services in relation to their clinical practice. Thesis (M.Sc.). University of Oslo.
- Hammer, J., 1990. Reengineering work: don't automate, obliterate. *Harvard Business Review*, July-August, 104-112.
- Hardon, A., Boonmongkon, P., Streefland, P., Tan, M.L., Hongvivatana, T., Geest, S.V.D., Staa, A.V., Varkevisser, C., Chowdhury, M., Bhuiya, A., Sringeriyuang, L., Dongen, E.V. and Gerrits, T., 2001. *Applied health research manual: anthropology of health and health care*. Netherlands: Het Spinhuis Publishers.
- Heeks, R., 1998. *Information age reform of the public sector: the potential and problems of IT for India* [online]. Institute for development policy and management, University of Manchester. Available from: http://www.man.ac.uk/idpm/idpm_dp.htm [Accessed 21 January 2003].
- Heeks, R., Mundy, D., and Salazar A., 1999. *Why health care information systems succeed or fail* [online]. Institute for development policy and management, University of Manchester. Available from: http://idpm.man.ac.uk/wp/igov/igov_wp09abs.htm [Accessed 01 April 2003].
- Helfenbein, S., 1987. *Technologies for management information systems in primary health care*. Geneva: World Federation of Public Health Associations.
- Ince, D.C. and Hekmatpour, S., 1987. Software prototyping: progress and prospects. *Information and software technology*, 29 (1), 8-14.
- Kaasbøll, J. and Nhampossa, L.J., 2002. Transfer of public sector information systems between developing countries: South-South corporation. In: S. Krishna and S. Madon., eds. *Proceedings of the IFI WG9.4 conference on information and communication technologies and development: new opportunities, perspectives, and challenges*, Bangalore 29-31 May 2002. Bangalore: Indian Institute of Management, Bangalore (IIMB), 507-517.
- Kaplan, B., and Dorsey, P., 1991. *Requirements analysis interviewing: alternative perspectives (Technical Report 91-021)*. Washington, D.C: The American University, department of computer science and information systems.

- Kaplan, B., 1991. Models of change and information systems research. In: H.E. Nissen, H.K. Klein, and R. Hirschheim, eds. *Information systems research: contemporary approaches and emergent traditions*. Amsterdam: North Holland Press, 593-611.
- Kimaro, F, and Spletstoesser, D., 2000. Benefits of IT-based decision-making in developing countries. *Electronic journal of information systems in developing countries*, 3 (3), 1-12.
- Kirkpatrick, L.A., 2000. A simple guide to SPSS for Windows. Belmont, CA: Wadsworth.
- Kleiman, A., 1980. *Patients and healers in the context of culture*. Berkeley: University of California Press.
- Kling, R. and Scacchi, W., 1982. The web of computing: computer technology as social Organisations. *Advances in computers*, 21, 1-90.
- Kling, R., 1987. Defining the boundaries of computing across complex organisations. In: R. Boland Jr. and R.A. Hirschheim, eds. *Critical issues in information systems research*. Chichester: John Wiley, 307-362.
- Kling, R., 2000. Learning about information technologies and social change: the contribution of social informatics. *The information society*, 16, 217-232.
- Kock, N.F.Jr., 1997. Myths in organisational action research: reflections on a study of computer-supported process redesign groups. *Organizations and society*, 4 (9), 65-91.
- Kraemer, K.L., and Dutton, W.H., 1991. Survey research in the study of management information systems. Thesis (MA). Harvard Business School, Boston.
- Ledford, G.E. and Mohrman, S.A., 1993. Looking backward and forward at action research. *Human relations*, 46 (11), 1349-1359.
- Lippeveld, T., Foltz, A., and Mahouri, Y.M., 1992. Transforming health facility-based reporting systems into management information systems: lessons from the Chad experience. Thesis (MA). Cambridge, Harvard Institute of International Development.
- Lippeveld, T. and Sapirie, S., 2000. Approaches to strengthening health information systems. In: T. Lippeveld, R. Sauerborn, and C. Bodart, eds. *Design and implementation of health information system*, Geneva: World Health Organisation, 243-252.
- Lippeveld, T., Sauerborn, R., and Bodart, C., eds., 2000. *Design and implementation of health information systems*. Geneva: World Health Organisation.

- Lungo, J.H., 2003. Legacy information systems in health management information systems: a case study from Mozambique. In: *The public health 2003 conference on health systems, development, and equity*, Holiday Inn Eastern Boulevard 24-26 March 2003. Cape Town: Public Health Association of South Africa and Health Systems Trust, 149.
- Macome, E., 2002. The dynamics of the adoption and use of ICT - based initiatives for development: results of a field study in Mozambique. Thesis (PhD). University of Pretoria.
- Markus, M.L. and Robey, D., 1988. Information technology and organisational change: causal structure in theory and research. *Management science*, 34, 583-598.
- McCoy, D., and Bamford, L., 1998. *How to conduct a rapid situation analysis: a guide for health districts in South Africa*. Durban, South Africa: Health Systems Trust.
- McLaughlin, J., 2001. Using health information to sustain support for health reform in Africa. In: *The RHINO workshop on issues and innovation in routine health information in developing countries*, The Bolger Center, Protomac, MD, USA 14-16 March 2001. Arlington, VA 22209, USA: MEASURE Evaluation, JSI Research and Training Institute, 71-73.
- Microsoft, 2000. *Microsoft SQL Server 2000 Chapter 19: data extraction, transformation, and loading techniques* [online]. Available from: <http://www.microsoft.com/technet/sql2000/part5/c1961.asp> [Accessed 04 February 2003].
- MISAU, 2001. *Strategic plan for the health sector (PESS) (2001-2005-2010) (a translation of the original document in Portuguese)*. Maputo: Ministry of Health (in Portuguese, Ministério da Saúde (MISAU)).
- Moen, A., 2002. Nursing leadership when an electronic patient record system is introduced in Norwegian hospital. Dissertation (Dr. polit). University of Oslo
- MoH-TZ, 1993. *Health management information system (HMIS) implementation plan 1993-1996*. Dar es Salaam: Ministry of Health in Tanzania.
- MoH-TZ, 1998. *National district health planning guidelines*, 2nd ed. Dar es Salaam: Tanzania Primary Health Care Secretariat, Ministry of Health in Tanzania.
- MoH-TZ, 2000. *Health management information system review 2000*. Dar es Salaam: Ministry of Health in Tanzania.
- MoH-TZ, 2002. *Health Facility MTUHA Version 2.0 Guideline Manual*. Dar es Salaam: Ministry of Health in Tanzania.

- Morgan, D.L., 1993. Qualitative content analysis: a guide to paths not taken. *Qualitative health research*, 3 (1), 112-121.
- Mswia, R. 2002. Dar es Salaam demographic surveillance system. *Population and health in developing countries*, 1, 143-150.
- Mswia, R., 2002. Hai district demographic surveillance system. *Population and health in developing countries*, 1, 151-158.
- Mujahid, Y.H., 2002. Digital opportunity initiative for Pakistan. *Electronic journal of information systems in developing countries*, 8 (6), 1-14.
- Mumford, E. and Weir, M., 1979. *Computer systems work design: the ethics method*. London: Associated Business Press.
- Muquingue, H., Kaasbøll, J., and Berg, O., 2002. The status of health management and information management in the Mozambican health districts: overview and preliminary findings. In: S. Krishna and S. Madon., eds. *Proceedings of the IFI WG9.4 conference on information and communication technologies and development: new opportunities, perspectives, and challenges*, Bangalore 29-31 May 2002. Bangalore: Indian Institute of Management, Bangalore (IIMB), 497-506.
- Mursalin, S. and Haque, N., 2001. The politics of HIS restructuring in Pakistan: the importance of policy analysis. In: *The RHINO workshop on issues and innovation in routine health information in developing countries*, The Bolger Center, Protomac, MD, USA 14-16 March 2001. Arlington, VA 22209, USA: MEASURE Evaluation, JSI Research and Training Institute, 169-178.
- Mwaluko, G.M.P., Neuvians, D. and Pazvakavambwa, B., 1996. *Health sector reforms in Eastern and Southern Africa: a training manual for district health workers*. Harare, Zimbabwe: Biomedical Research and Training Institute.
- Newman, M. and Noble, F., 1990. User involvement as an interaction process: a case study. *Information systems research*, 1 (1), 89-113.
- Ngatunga, S. (ngatunga4sam@yahoo.com). (26 Feb 2003). RE: *Private health facilities*. E-mail to Juma Hemed Lungo (jumal@ifi.uio.no).
- O'Brien, R., 1998. An overview of the methodological approach of action research [online]. Available from: <http://www.web.net/~robrien/papers/arfinal.html> [Accessed 13 April 2003].
- Pater, D., 2003. Interview. In: *Thirteen O'clock African business tonight*. TV, STV and TVA. 2003 January 16.

- Peters, M. and Robinson, V., 1984. The origins and status of action research. *The journal of applied behavioural science*, 20 (2), 13-124.
- RHINO, 2001. *The RHINO workshop on issues and innovation in routine health information in developing countries*, The Bolger Center, Protomac, MD, USA 14-16 March 2001. Arlington, VA 22209, USA: MEASURE Evaluation, JSI Research and Training Institute.
- Robey, D. and Farrow, D., 1982. User involvement and information system development: a conflict model and empirical test. *Management science*, 28,73-85.
- Rodrigues, R.J. and Israel, K., 1995. *Conceptual framework and guideline for the establishment of district-based information systems*(document PAHO/COC/3.1/95.1). Barbados: Pan American Health Organisation, Office of the Caribbean Program Coordination.
- Rubona, J. J., 2001. Routine health information systems that operate in Tanzania. In: *The RHINO workshop on issues and innovation in routine health information in developing countries*, The Bolger Center, Protomac, MD, USA 14-16 March 2001. Arlington, VA 22209, USA: MEASURE Evaluation, JSI Research and Training Institute, 183-193.
- Sandford, P. Annet, H., and Cibulskis, R., 1992. What can information systems do for primary health care? An international perspective. *Social science and medicine*, 34, 1077-1087.
- Sapirie, S., 2000. Assessing health information systems. In: T. Lippeveld, R. Sauerborn, and C. Bodart, eds. *Design and implementation of health information system*, Geneva: World Health Organisation, 73-87.
- Sauerborn, R., 1991. *Proposals for an information system for SESA project*. Thesis (MA). Cambridge, Harvard Institute of International Development.
- Sauerborn, R., 2000. Using information to make decision. In: T. Lippeveld, R. Sauerborn, and C. Bodart, eds. *Design and implementation of health information system*, Geneva: World Health Organisation, 33-48.
- Sauerborn, R. and Lippeveld, T., 2000. Introduction. In: T. Lippeveld, R. Sauerborn, and C. Bodart, eds. *Design and implementation of health information system*, Geneva: World Health Organisation, 1-14.
- Silverman, D., 2000. *Doing qualitative research: a practical handbook*. London: Sage.
- Simba, D. O. (24 February 2003). Re: [hisptanzania] What is "total deliveries"? *hisptanzania* [online]. Available from: hisptanzania@yahoo.com [Accessed 03 April 2003].

- Simwanza, A. and Church, M., 2001. Establishment of an information culture: achievements and challenges in Zambia. *In: The RHINO workshop on issues and innovation in routine health information in developing countries*, The Bolger Center, Protomac, MD, USA 14-16 March 2001. Arlington, VA 22209, USA: MEASURE Evaluation, JSI Research and Training Institute, 227-234.
- Sommerville, I., 2001. *Software Engineering*, 6th edition. Essex CM20 2JE, UK: Addison-Wesley.
- Spanos, Y., Prastacos, G.P, and Poullymenakou, A., 2002. The relationship between information and communication technologies adoption and management. *Journal of information and management*, 39, 659-675.
- Strauss, A., and Corbin, J., 1990. *Basics of qualitative research: grounded theory procedures and techniques*. Newbury Park, CA: Sage.
- Susman G.I. and R.D. Evered, R. D., 1978. An assessment of the scientific merits of action research. *Administrative science quarterly*, 23 (4), 582-603.
- Tanner, M. and Lengeler, C., 1993. From the efficacy of disease control tools to community effectiveness. *Transactions of the royal society of tropical medicine and hygiene*, 87, 518-523.
- Trist, E., 1976. Engaging with large-scale systems. *In: A. Clark, ed. Experimenting with organizational life: The action research approach*, New York: Plenum.
- Visser, R. (27 January 2003) Re: Quality of data. *District Health Information System* [online]. Available from: dhis@lists.healthlink.org.za [Accessed 06 April 2003].
- Wabwire-Mangan, F., Kambic, R.T., and Mukooyo, E., 2001. A proposal to develop a sustainable digital health information systems infrastructure in Uganda. *In: The RHINO workshop on issues and innovation in routine health information in developing countries*, The Bolger Center, Protomac, MD, USA 14-16 March 2001. Arlington, VA 22209, USA: MEASURE Evaluation, JSI Research and Training Institute, 213-226.
- Walsham, G., Symons, V., and Waema, T., 1988. *Information systems as social systems: implications for developing countries*. London: Oxford University Press.
- Walsham, G., 1995. The emergence of interpretivism in IS research. *Journal of information systems research*, 6 (4), 376-394.
- Wambura, C.M.M., 1998. Evaluation of health management information system in Tanzania. Thesis (Advanced diploma in public health). Institute of Development Management, Mzumbe, Tanzania.

- WHO, 1987. *Report of the interregional meeting on strengthening district health systems, based on primary health care*, Harare, Zimbabwe 3-7 August 1987. Geneva: World Health Organisation.
- WHO, 1998. *District health systems: an overview report on the challenge of implementation of district health service for primary health care*. Geneva: World Health Organisation.
- Whyte, W.F., Greenwood, D.J., and Lazes, P., 1991. Participatory action research: through practice to science in social research. In: W.F. Whyte, ed. *Participatory action research*. Newbury Park, CA: Sage, 19-55.
- Wilson, R. and Smith, D.L., 1991. Microcomputer applications for primary health care in developing countries. *Infectious disease clinics of North America*, 5, 247-264.
- Wilson, R. and Sapanuchart, T., 1993. *Primary health care management advancement programme*. Washinton, DC: Aga Khan Foundation.
- Wilson, R., 2000. Using computers in health information systems. In: T. Lippeveld, R. Sauerborn, and C. Bodart, eds. *Design and implementation of health information system*, Geneva: WHO, 198-212.
- Wilson, R., Rohde, J., Puchert, R. and Hedberg, C., 2001. South Africa's district health information systems: case study from Eastern Cape province. In: *The RHINO workshop on issues and innovation in routine health information in developing countries*, The Bolger Center, Protomac, MD, USA 14-16 March 2001. Arlington, VA 22209, USA: MEASURE Evaluation, JSI Research and Training Institute, 81-93.
- Wood-Harper, T., Antill, L. and Avison, D.E., 1985. *Information systems definition: the multiview approach*. Oxford: Blackwell Scientific.
- Wood-Harper, A.T., and Davies, L.J., 1990. Worldview boundaries and information systems development: cross-cultural issues. In: S.C. Bhatnagar, and N. Bjørn-Andersen, eds. *Information technology in developing countries*. North-Holland: Elsevier Science Publishers B.V. and IFIP, 63-77.
- Wood-Harper, T., and Bell, S., 1990. Information systems development for developing countries. In: S.C. Bhatnagar, and N. Bjørn-Andersen, eds. *Information technology in developing countries*. North-Holland: Elsevier Science Publishers B.V. and IFIP, 23-39.

APPENDIX A

INTERVIEW GUIDE QUESTIONNAIRES

1. Questionnaire used in Mozambique fieldwork

This research is for academic purposes whereby the findings will be presented at the Faculty of Medicine, Eduardo Mondlane University. There are no right and wrong answers. All information will be strictly confidential, please feel free to respond on these questions.

Topic: *Data Collection, Storage, Retrieval, and Analysis for Health Information System in Mozambique.*

Interviewer:.....
 Meeting
 Place:.....Date:.....Start:.....End:.....
 Interview
 Type:.....Language:.....
Interviewee:
 Name:.....Occupation:.....
 Age:.....Marital Status:.....Birth Place:.....Children:.....

DATA COLLECTION

What categories of data do you have?

Que categorias de dados você tem?

Who collect data at the department?

Quem recolhe dados no departamento?

What instruments of data collection are used? Eg. Forms, letters, memos etc.

Que instrumentos de recolha de dados são utilizados? Ex. Impressos, cartas, memoranduns etc.

How much time (hours/days) do you spend in collecting data and writing reports?

Quanto tempo (horas/dias) você leva na recolha de dados e na feitura de relatórios?

DATA STORAGE

Where data are stored (Piled forms, in computer etc)?

Onde é que os dados são guardados (arquivos, no computador etc)

Are there any problems with data storage? YES or No If YES what are they?

Existe algum problema com a conservação de dados? Sim ou Não? Se sim, quais são?

DATA ANALYSIS

What do you do with the forms (data) when you have completed them?

O que é que você faz com os impressos (dados) quando estiverem completos?

What instruments do you use to calculate statistics from the data?

Que instrumentos você usa para calcular as estatísticas a partir dos dados?

How much time (hours/days) do you spend in analysing data and writing reports?

Quanto tempo (horas/dias) você leva para analisar os dados e produzir relatórios?

INFORMATION LOW

Do you abide to produce report at a defined time intervals?

Você produz relatórios em intervalos definidos?

Who are interested with your reports?

Quem está interessado nos seus relatórios?

USE OF INFORMATION

What are the uses of your information within the dept. and outside?

Qual é uso da sua informação dentro do departamento e fora?

Do you regard this information is correct? **YES or No**

Você considera esta informação correcta? Sim ou Não

COMPUTER

Does your department have computers?

O seu departamento tem computadores?

Are the data you collect being entered in a computer?

Os dados que você recolhe são conservados num computador?

Do you think computer software can improve data processing at the dept.? **YES or No**

Você acha que o software do computador pode melhorar o processamento de dados no departamento? Sim ou Não

If yes how?

Se sim, como?

Are there any computer training opportunities at your dept.? **YES or No**

Existe alguma oportunidade de formação em computador no seu departamento? Sim ou Não

COMMENTS

What gaps do you feel exist between the information you have and the information you need?

Que lacunas você julga existirem entre a informação que você tem e a que você precisa?

How can the information system and the use of information be improved?

Como podem ser melhorados o sistema de informação e o uso da informação?

2. Questionnaire used in Tanzania fieldwork

QUESTIONNAIRE BASED INTERVIEW GUIDE FOR HEALTH INFORMATION SYSTEM RESEARCH USED IN AN M. SC. STUDY IN BAGAMOYO, TANZANIA.

by

Juma Hemed Lungo. June 2002

“This is for getting an idea of what data you collect and what you do with it. There are no right or wrong answers. All replies are strictly confidential”.

KEY: Y=YES, N=NO, D=Don’t Know

Interviewer:.....

Meeting

Place:.....Date:.....Start.....End:.....

Interview

Type:.....Language:.....

Interviewee

Name:.....Occupation:.....Education:.....

Years of Service:..... Age:.....Marital status:.....

Birth Place:.....Children:.....

Institution: VILLAGE HP/DISPENSARY/HC/DH/DMO/RMO/MOH/NGO

TIME

How much time do you spend collecting data/filling registers/writing reports

Every day,

At the end of the week

At the end of the month.

How much of this time is spent analysing data/calculating indicators?

Every day

At the end of the week

At the end of the month

TARGET POPULATION

Do you have a defined area/population you serve? Y/N/D

What is the total population you serve? -----

Where did you get this figure from? -----

Do you know the number of people in the following groups?

Infants 0 to 1 year-----

Children 1 to 5 year-----

Number of pregnant women in fertile age-----

Number of deliveries-----

Number of women in fertile age-----

Number of school children-----

Others -----

INFORMATION SYSTEM

Do you keep/receive information on the following activities?

Outpatient	Y/N/D
Inpatient	Y/N/D
Antenatal cases	Y/N/D
Immunizations	Y/N/D
Home visit	Y/N/D
Community health activities	Y/N/D
0 to 1 year morbidity	Y/N/D
1 to 5 years morbidity	Y/N/D
Environmental health	Y/N/D
Others (specify)	Y/N/D

Do you analyse data at your level using the following?

Tables	Y/N/D
Graphs or pictures	Y/N/D
Indicators	Y/N/D
Used in reports	Y/N/D
Others (specify)	Y/N/D
Do you consider the information to be Easily available	Y/N/D
Accurate	Y/N/D
Complete	Y/N/D
Do you ever use information in your own work?	Y/N/D
If yes, how do you use it?	

COMPUTER

Does your institution have a computer? Y/N/D

Are the data you collect being entered in a computer? Y/N/D

If yes, at what level is the data being entered?-----

If yes, do you benefit from this? Y/N/D

How do you benefit from this? -----

Can a computer support you/your institution better? Y/N/D

If yes, how? -----

Does your institution need a computer? Y/N/D

If yes for what purpose? -----

INFORMATION FLOW

What do you do with the forms when you have completed them?

Analyse locally Y/N/D

Fill and send Y/N/D

Other -----

What do you think they do with them?

Analyse	Y/N/D
Use it for planning	Y/N/D
For annual report	Y/N/D
Send it to higher level	Y/N/D
Nothing	Y/N/D
Other -----	
Are you getting the monthly statistics on time?	Y/N/D
From sub centres	Y/N/D
From PHCs	Y/N/D
Are you sending the monthly statistics on time?	Y/N/D
From sub centres	Y/N/D
From PHCs	Y/N/D

How are you sending the monthly statistics?

Carrying it myself	Y/N/D
Sending it with other people	Y/N/D
By Post	Y/N/D
Others (specify)-----	
Do you have problems in reporting/sending information to the next level?	Y/N/D
If yes, specify-----	

How are you calculating the monthly statistics?

Not calculating	Y/N/D
By hand	Y/N/D
By calculator	Y/N/D
Other (specify) -----	
Are you using the information from the monthly statistics?	Y/N/D
If yes, specify -----	

FEEDBACK

Do you ever get feedback on results you send up?	Y/N/D
If yes, how often?	
Every week	
Every month	
Once a year	
Twice a year	
Quarterly a year	
Once in a while	
if yes, in what form do you get the feedback?	
Supervision	
Written feedback	
Reports	
Graphs	
Any others (specify) -----	

APPENDIX B

DATA COLLECTION AND REPORTING INSTRUMENTS

1. Form A04: District report for immunisation services

Source: Ministry of Health, Mozambique

REPÚBLICA DE MOÇAMBIQUE
MINISTÉRIO DA SAÚDE
MOSAUÍ

PROVINCIA Beira DISTRITO Andaraia
MES Junho ANO 2001

RESUMO MENSAL DO PAV PARA DISTRITOS

GRUPO ETÁRIO	4-11 MESES		12 MESES (OU MAIS)		TOTAL APLICÁVEIS	EXCERCI- CABAS
	U1	U2	U1	U2		
V.A. <input checked="" type="checkbox"/>						
S.C.S.	486	70	556	0-1		
POLIO APLICACAO PREVALENT	612		612			
DTP P-DOSE	846	11	857	11		
POLIO P-DOSE	906	11	917			
DTP P-DOSE	900	5	905	11		
POLIO P-DOSE	900	5	905			
DTP P-DOSE	850	11	861			
POLIO P-DOSE	850	11	861			
SUMARIO	815	22	837	5		

GRUPO ALTO	V.A.T.			
	U1	U2	U3	U4
MULHERES GRÁVIDAS	573	482	1155	20
MULHERES DE 14-49 ANOS	156	257	413	3
ORGANIS DA ESCOLA	-	-	-	-
TRABALHADORES	20	5	25	

ELECTORES
 # Deseja e não se querem V.T. e/ou outros no registo eleitoral?
 Nenhum de U.S. Nenhum de U.S.

VACINAS PREVENICO

10. Quantos postos está a trabalhar?

MUNICÍPIO QUANTIDADE DE PREVENICO

10. Número de filas em que os lugares estão a trabalhar, durante o mês

5

3. Antenatal Register (Source: HMIS in Tanzania 2002)

REJESTA YA WAJAWAZITO KIJILI/MTAA <u>DUMBA</u>										
HUDHURIO LA KWANZA LA MAMA MJAMZITO										
Tarehe	Namba ya awabazito	Jina	Uchima kati	Uzazi wa mtoto kwa wazi		Vitokoni vya hatari				
				<20	20+	Idadi ya watoto	Uzazi	Uzifa	KM	CS
02 Jan	01	02 Mwanvua Ally	N		✓	2	22	153	0	0
2 Jan	02	02 Halima Abdu	N	✓		4	28	155	0	0
2 Jan	03	02 Aisha Athumani	H		✓	4	30	154	0	0
2 Jan	04	02 Mariamu Manana	N	✓		1	21	156	0	0
3 Jan	05	02 Atie Omari	H		✓	3	32	165	0	0
2 Jan	06	02 Amina Yusuf	N		✓	3	28	172	0	0
7 Jan	07	02 CESEHA BONIFAC	N	✓		2	25	160	0	0
7 Jan	008	02 Husna Digallo	H		✓	1	20	158	0	0
7 Jan	009	02 Zakia Mohamedi	N		✓	5	31	168	0	0
8 Jan	010	02 Ester Andrea	H		✓	1	20	155	0	0
9 Jan	011	02 Aisha Magwen	H		✓	2	18	149	0	0
9 Jan	012	02 Sofia Shabani	H	✓		3	28	154	0	0
9 Jan	013	01 Mwangizi Miraji	H	✓		1	18	161	0	0
11 Jan	014	02 DINA KWADA	H	✓		1	28	164	0	0
11 Jan	015	02 Rettema Ally	H		✓	7	42	161	0	0
12 Jan	016	02 Nise Musiti	H	✓		1	19	162	0	0
14 Jan	017	02 Mariamu Omari	H		✓	2	22	142	0	0
16 Jan	018	02 Pili Rastidi	H		✓	3	24	157	0	0
16 Jan	019	02 Flora Morisi	H	✓		6	37	155	0	0
17 Jan	020	02 Siamé Omari	H		✓	4	28	156	0	0
17 Jan	021	02 Mwasiti Athu	H	✓		5	35	162	0	0
18 Jan	022	02 Halima Omari	H	✓		2	24	151	0	0
18 Jan	023	02 Kambora Salumu	H		✓	1	20	149	0	0
21 Jan	024	02 Maria Yasa	H		✓	3	23	157	0	0
22 Jan	025	02 Mariamu Buola	H	✓		3	25	156	0	0

Kumbuka: KM = Kuharibu mimba CS = Kuzaa kwa kupasuliwa A = Anemia O = Oedema P = Protenuria

4. Health facilities quarterly report (Source: HMIS in Tanzania 2002)

TABLE D4.5: HF QUARTERLY REPORT DATA - Part 7 Quarter I Year 2002 Page 1

Category enter HF codes-	001	002	003	004	005	006	007	008	009	010
OPD attendances	11430	1849	3989	1384	2571			2774	1970	1065
Dental Clinic attendances	302	31	0	-	0			0	0	0
Dent Clin reattend with compl	2	0	0	-	0			0	0	0
DTC number cases		37	25	50	1814			186	33	22
DTC cases with dehydration		27	25	11	925			11	33	9
ANC new clients	234	30	328	169	121	40	46	39	77	22
ANC clients tested for syphilis	67	30	328	119	36	-	-	0	0	0
ANC clients pos for syphilis	10	2	23	6	2	-	-	0	0	0
ANC clients receiving TT2+	299	22	58	100	92	32	26	28	42	8
Deliveries at HF (inc BBA)	222	17	106	79	67	20	44	8	3	4
Deliveries by trained TBAs	10	13	65	30	26	7	1	85	81	25
Total deliveries	232	30	171	109	93	27	45	93	84	29
Chn <1 year registered	230	30	229	137	106	44	44	93	84	35
Chn <1 year reg mother per TT	227	22	171	137	77	44	44	78	84	34
BCG imm chn <1 yr	271	30	240	137	106	36	43	45	84	36
DPT 1 imm chn <1 year	267	39	290	137	108	42	43	51	95	35
DPT 3 imm chn <1 year	243	37	284	122	107	48	39	39	72	38
Polio 3 imm chn <1 year	255	37	287	122	100	48	45	39	73	38
Measles imm chn <1 year	247	31	273	105	106	40	22	58	59	55
Chn weighed at measles imm	247	31	275	105	108	40	22	59	59	55
Chn >60% WA at measles imm	4	2	0	1	2			1	0	4
Postnatal Vitamin A supplement	222	30	106	79	93			71	84	25
Chn at Measles imm w/ A sup	247	31	273	122	188	40	22	59	59	55
FP Total acceptors	114	164	836	397	224			103	157	92
FP New acceptors	136	30	258	52	36			56	47	28

5. Indicators for the district quarterly report (Source: HMIS in Tanzania 2002)

Page 3

DISTRICT QUARTERLY REPORT

Part 8: Indicators

Enter the Numerator and Denominator values from pages 1 and 2. Calculate the Indicator Value for each indicator. If the indicator value is not between the Target Value and the Threshold Value there is a serious problem. Write down a Yes or No to indicate whether there is a problem.

Indicator	Numerator	Denominator	IND	TAR	THR	Prob (Y/N)
1. Average number of commodities having a stock out in LL health facilities	<u>200</u> Commodities O/S total (Table D4.2)	<u>28</u> Number Health Facility Reports (Table D4.2)				
2. OPD attendances per capita	<u>56778</u> OPD Attendances (Table D4.6)	<u>242390</u> Total population (Table D1.6)				
3. ANC clients - percent of all births	<u>1973</u> ANC new clients (Table D4.6)	<u>2888</u> Quarterly births (Table D1.6)	$\frac{683}{\times 100}$	90	80	Y
4. ANC clients receiving TT Dose 2+ - percent of ANC clients	<u>1207</u> ANC clients receiving TT 2+ (Table D4.6)	<u>1973</u> ANC new clients (Table D4.6)	$\frac{61}{\times 100}$	90	75	Y
5. Attended Deliveries - percent of all births	<u>1620</u> Total deliveries (Table D4.6)	<u>2888</u> Quarterly births (Table D1.6)	$\frac{56}{\times 100}$	60	40	N
6. Child registration - percent of all births	<u>1851</u> Chn <1 year registered (Table D4.6)	<u>2888</u> Quarterly births (Table D1.6)	$\frac{64}{\times 100}$	100	80	Y
7. Percent of Children <1 year receiving DPT 3	<u>1684</u> DPT 3 imm chn <1 year (Table D4.6)	<u>2888</u> Quarterly births (Table D1.6)	$\frac{583}{\times 100}$	90	80	Y
8. Percent of children <1 year receiving Measles immunisation	<u>1661</u> Measles imm chn <1 year (Table D4.6)	<u>2888</u> Quarterly births (Table D1.6)	$\frac{575}{\times 100}$	90	75	Y
9. Percent of children severely underweight at measles immunisation	<u>61</u> Chn <6% WA at measles imm (Table D4.6)	<u>1661</u> Chn weighed at measles imm (Table D4.6)	$\frac{3.7}{\times 100}$	2	6	N
10. Family Planning new acceptance rate	<u>1105</u> Family Planning uses acceptors (Table D4.6)	<u>12265</u> Women 15-49 (Table D1.6)	$\frac{9}{\times 100}$	15	10	
11. Health facility reporting rate	<u>24</u> Number health facility reports (Table D4.6)	<u>35</u> Number of health facilities (Table D1.1)	$\frac{68.6}{\times 100}$	100	100	Y

x 100 means that the the numerator is multiplied first by 100 when calculating the indicator.

APPENDIX C

FIELDWORK ENTRANCE PROTOCOL

JAMHURI YA MUUNGANO WA TANZANIA
WIZARA YA AFYA



Airwazi ya Simu: "AFYA",
DAR ES SALAAM
Simu: 2128261 -7
Fax: (255) -22 - 2139951/110986/138283
Unapojibu tafadhali tuja:

S.L.P. 9083,
DAR ES SALAAM

Kumb. Na: BC 209/395/01/228
13 Juni 2002

Kwa Yeyote Anayehusika:

Yah: Barua ya Utambulisho kwa Juma Lungo

Mhusika aliyetajwa hapo juu ni mwanafunzi wa Kitanzania katika Chuo Kikuu cha Oslo kilichopo nchini Norway. Ni mwanafunzi anayesomea shahada ya juu katika fani ya Mifumo ya Taarifa (Information Systems). Mwanafunzi huyu amechagua kufanya utafiti kuhusu MTUHA katika Tanzania kama sehemu ya kukidhi matakwa ya kozi. Hivyo Wizara ya Afya inaomba umpokee na umpe msaada utakaohitajika ili afanye vizuri katika masomo yake na tunatarajia utafiti atakaoufanya utasaidia kuboresha MTUHA hapa nchini.

Maximilian Mapunda
Kny Katibu Mkuu

APPENDIX D

ABSTRACTS OF REPORTS AND PAPERS

1. Fieldwork report at José Macamo General Hospital

- A fieldwork attachment report presented at the Faculty of Medicine, 25th March 2002

Report Title:

Collection, Storage, Retrieval, and Analysis of Data for a Health Information System: A Case Study from José Macamo General Hospital, Mozambique

Introduction

The slogan “information is power” is always true. Health Information System cannot be neglected to this truth. They need well-defined protocols on how to collect data, store data, and analyse data so that they generate reliable information for the purposes of improving health delivery services to better situations.

Many researches have been conducted on data collection, storage, and analysis, which are now in place in health information systems. With today’s era of computer technology, these old methods of data collection, storage, analysis, and reporting health data, seems to be obsolete.

With background of computer science I have, the topic is of interest to me because it is trying to answer the questions of where computer systems can be applied in health information system and how the health delivery system can benefit from the introduction of computer technology.

I have used Qualitative research methodology, to answer my research questions. The methods applied include: Observation method, Interview, Text and Document Analysis and Audio Recording the interviews. At the end of this report, is the ANNEX chapter where I attached all documents I have collected from the field. Mainly are data collection forms and report.

The study results show that data are collected by using paper forms and register books, however, no guideline found to that guides health workers on how to complete the registers, young workers learn from experienced workers. Each health centres was attached to a supervision hospital. A statistics and clinic officer from the supervision hospital visits the health centres in order to collect health data monthly. Data collected in the daily registers are transcribed into monthly reporting forms. There are limited office spaces and data analysis tools, as it was revealed that forms and books are displayed on the floor, tables, and uncovered shelves and to calculate totals “sticks” are sometime used if the calculators are not available. The resulting reports are used for internal control purposes, presented to donors, and channels to the Ministry of Health via the district.

2. Information flows in the national health information system in

Mozambique.

Report Title:

Analysis of health information flows in the Ministry of Mozambique.

Presented at the Ministry of Health, Mozambique, 25th May 2002

Introduction

This report is drawn from a study carried out by a group of five informatics master students, from Eduardo Mondlane University. We visited the Ministry of Health several times in the beginning of April and the beginning of May. Gaza provincial headquarter was visited on two fields trip. Trip one was 22 April - 26 April 2002, the second was 8 May 2002. We also visited Inhambane province but due problems there we were unable to find any one to speak to (they were gone or in meetings and the computer was broken down and taken all the way to Maputo for maintenance).

In this report we show how the information system used by MISAU is facing several problems concerning the way in which it collects and analyzes health data in Mozambique.

It seems to us as a group who participated on this study that the software SIS - Sistema de Informação de Saúde, currently used by MISAU does not offer to their potential users the appropriate tools for analysis of the data they are collecting.

As part of the study, we designed software that extract data from the old database, and then format the data into a text file that can be imported into DHIS – District Health Information Software

3. DHIS Training workshop report

- Paper presented at the department of mathematics and informatics, Eduardo Mondlane University (UEM), 29th November 2002 as a Final Examination of the course “INF-DID-N Learning and teaching IT, 9 credits” I followed at UEM.

End User Training: emphasis should be why they need the system.

Juma H. Lungo and Teotónio G. S. Fumo
Department of Informatics
University of Oslo

Email: jlungo@udsm.ac.tz, tfumo@excite.com

Abstract

The purpose of this study was to evaluate user-training approaches in how they can motivate the users to use new computer software system. Data was collected from a 10 day user training course designed for 40 health workers who were learning how to collect, compile and analyse health data using computer software.

Sample health data used in the training of the software were acquired from the Province where the trainees came from. The software was loaded with sample data and filled manual forms were collected for the trainees to practice introducing data in the software. Trainees were asked to generate the same reports and graphs electronically that they used to generate manually, as an exercise.

The study results show that trainees were able to enter data and generate reports and graphs within short time compared to the time used to generate the same reports and graphs manually. At the end of the course, many trainees asked for a copy of the software so that they can install and use it at their working place. While comparing the attitude of the trainees toward the use of computer software before the start of the course and at the end of the course, it was noted that trainees were positive about the computer software and seemed to be motivated by the course.

Key Words: End User Training, Health Information System, computer software

4. Public health 2003 conference paper

- Paper accepted at the Public Health 2003 Conference 24-26 March 2003, Cape Town

LEGACY INFORMATION SYSTEMS IN HEALTH MANAGEMENT INFORMATION SYSTEMS: A CASE STUDY FROM MOZAMBIQUE.

Juma Hemed Lungo,
Department of Informatics,
University of Oslo.
Email: jumal@ifi.uio.no

Abstract

Developing countries strive to reform their Health Management Information Systems (HMIS) by replacing old computer systems. Although old systems contain valuable information and people are accustomed to, the process of upgrading them is expensive and prone to errors. These systems are known as legacy information systems (LIS). Legacy information systems were developed using old computer technologies, usually do not have system design documentation and over time have gone through several changes in order to meet changing requirements. Because legacy information systems tend to be installed at the provincial and national levels and have been in operation for decades, can be regarded as the backbone of the HMIS. This part of Masters thesis research paper conducted from March to May 2002 discusses implications of legacy information systems in health management information systems using a case study from Mozambique where the process of introducing District Health Information Software (DHIS) as an alternative computer system in the HMIS seems to be slowed down by existing legacy information systems. The Ministry of Health in Mozambique is reluctant to relinquish its LIS in order to switch to the DHIS, because the LIS has historical health data invested in throughout the last ten years. The extraction, transformation, and loading (ETL) tool used to migrate health data from the legacy information system to the District Health Information Software in Mozambique is presented.

Key Words: Legacy information systems, information technology, developing countries, health management information systems

5. Comparison of Extraction Transformation and Loading Solutions

Name: Report about advantages/disadvantages of developing specific/general tool in order to extract data from an old database to the DHIS

Last edited: 02 February 2003

Last edited by: Alex Van Oostenrijk (first editor: Tore Skobba)

Version: 2.0

Case

Juma Lungo and Tore Skobba made two different tools to import data from the Computer database of the national health information system in Mozambique (SIS) into the district health information software (DHIS) database. The two solutions were completed and were used to extract data from the SIS database to the DHIS in May 2002. SIS stores its data in **dBase III**. DHIS was developed exclusively using **Microsoft** proprietary technology, stores its data in Access, presents its information in Word and Excel, and uses **Visual Basic** as the glue. The import of data from external sources is accessed through a pre-defined text file. Two solutions have been made:

Lungo's: Developed in Visual Basic with Access database as its back end, made to be a *specific solution* using Microsoft technology.

Tore's: Developed in Java with no database as its back end, made to be a *general solution*, which is able to cater for several different data sources. It made with non-use of Microsoft technology except for drivers to access Microsoft data sources.

Evaluation of different properties

Property	General solution	Specific solution
Time to develop	2-3 months and still not finished, although managed to finish this specific problem.	2-3 weeks and solved specific problem.
Defining problem	Difficult to define problem, need to cater for future problems, trade-off between the current database and the future ones.	Easy defined problem, started by solving a small part of the problem, then expanding.
Time and resource use	Can use much time and resources because it will be usable in future scenarios, thus invest time now to save time in future.	Cannot invest so much time and resources due to limited usability to specific problem.
Compatibility	JAVA, easy deployment on many platforms but requires Java runtime (extra files). GUI and dialog windows (example: file explorer) are not similar to	DHIS and specific solution was developed in Microsoft (MS) technology, advantage of user being used to dialogs and GUI. Easy to access Access, Excel,

Property	General solution	Specific solution
	what the users are used to. The program stands out from the rest of DHIS package as being different. Difficult to access Microsoft proprietary technology.	Word and other MS proprietary technologies. Also use it to make reports etc.
Usability of fieldwork	Low if not well planned, need to have made a usable solution before. Otherwise, most time is spent programming and not solving field problems.	High, can fix problem there and contact responsible persons quickly. The program was developed in the field.
Usability of software	Can make easy GUI and usability because high investment of time. Mapping is difficult, unable to take advantages of structure in existing data sources. People only need to learn one application for all data sources. Usability average for large group of problems.	Program made fast to cater for specific solution, no need to invest in GUI etc. Mapping easy because program can take advantage of structure in existing data source. People need to learn one application for each data source. Hard coded properties of existing data source. Usability good for specific problem.
Risk	High, much time and resources invested with high risk of failure.	Low, limited time and resources invested with medium risk of failure.
Required User Skill	Medium. Data sources need to be edited to conform to a basic structure.	Medium. User might have to edit hard coded properties when changing what to import.

Misc. on general solution:

Much information is stored in Microsoft files, but it is difficult to access them. Java might have been a bad choice due to most users using exclusively MS platforms. It is difficult to decide to which level data sources must be made to conform to, for the application to be able to understand them.

Misc. on specific solution:

Microsoft supports both MS Access and Dbase, making Visual basic a good choice. The developer has extensive experience in the design and implementation of relational databases. He is also a strong Visual Basic programmer (in the field he managed to program the most useful part of the application without having a single VB reference book) so no time was wasted in searching for references. All these factors have contributed to the short time taken to develop the application.

APPENDIX E

DISCUSSION OF THE STUDY FINDINGS USING EMAILS

1. Discussion for deliveries data analysis

Email 1:

To:	hisptanzania@yahoogroups.com
From:	"Daudi O. Simba" <dsimba@muchs.ac.tz> This is Spam Add to Address Book
Date:	Mon, 24 Feb 2003 13:08:21 +0300
Subject:	Re: [hisptanzania] What is "total deliveries"?

On Mon, 24 Feb 2003 00:18:12 -0800 (PST) Juma Lungo <jlungo@yahoo.com> wrote:

>Hi

>I am analyzing my field data, but I need some help. In the field, I
>was told that as soon as a newborn is received, it gets BCG first dose
>and Polio first dose on the spot. That means number of BCG fist dose
>given is equal number of Polio first dose given. The data I have
>(attached Figure 1) is not showing so, what are the possible reasons?

**Answer: The numbers will the same if and only if all the babies will
get the jab. Not all do. Reasons could be no vaccine, not vaccination
day, delivered awkward hour etc.**

>In the health facilities, total deliveries, number of birth-lives, and
>number of birth-deaths are recorded separately as different data
>elements. Now I compared total deliveries with number of children
>(deaths +lives). What I understand is that? Total deliveries = total
>children (lives + deaths). The data I have (attached Figure 2)
>deliveries are not equal to the total children reported (lives +
>deaths). Number of children is bigger than deliveries (Jan, March,
>May, June, July, Aug. and Sept.), I assumed there were twins, and
>somewhere number of deliveries is bigger than number of
>children (Feb, April, Oct. Nov. and Dec.), what can I say?

Answer: Errors in recording, transcription and collation.

>Lungo

Email 2:

At 14:12 24.02.2003 +0000, chedberg@mweb.co.za wrote:

Juma,

Firstly, both Sundeep and Daudi are pointing to the key sources of such discrepancies: Either it relates to gaps in service delivery, for instance due to the reasons Daudi suggests, or it relates to errors in data collection, capture, or aggregation. In South Africa, we normally find that even after using the DHIS with all its validation mechanisms

for about 2-2.5 years, most provinces still have identified errors in 3-5% of their data records. What we usually see is that districts with very dedicated people normally identifies and comment on such errors, but they are often not able to get correct values from the facilities. So the errors are either left in or they are replaced by regression values. In districts with more lazy or disinterested staff we find that such errors are just left in there, neither tagged for follow-up nor commented on. Our strategy has in general been to

- (a) Identify as many errors as possible and feed them back to the facilities as queries.
- (b) After some rounds of such corrections, fill in the gaps and correct the gross errors using trend values.

Regards, Calle

Email 3:

From:	Sundeep Sahay <sundeeps@ifi.uio.no>
Reply To:	hisptanzania@yahoogroups.com
To:	<hisptanzania@yahoogroups.com>
Subject:	Re: [hisptanzania] What is "total deliveries"?
Date:	Tue, 25 Feb 2003 11:10:58 +0100

Hi Lungo, agree with calle completely. even that has been our approach is to point out the anomalies, raise possible alternative questions and ask the doctors and health staff to try and provide some possible explanations. the important thing is for them to start reflecting critically about the data they collect and report, and start to ask questions around them. if conversations around data quality can be initiated, we are making "progress." it is not enough to point out things are wrong (because at least in India at least I think people know it), but try to ask questions about why they are so. Good luck, Sundeep

2. Discussion for lack of reporting of health facilities

Email 4:

From:	samuel ngatunga <ngatunga4sam@yahoo.com>
To:	Juma Hemed Lungo <jumal@ifi.uio.no>, <RMOOfficeTanga@gmx.net>
Subject:	Re: Private health facilities
Date:	Wed, 26 Feb 2003 23:39:59 -0800 (PST)

Dear Mr. Lungo,
All health facilities in Tanzania Mainland are required to report using MTUHA. The reasons for non-compliance can only be obtained from the DMO.
Best Regards,

Ngatunga

--- "jumal@ifi.uio.no" <jumal@ifi.uio.no> wrote:

> Hi

> Mzee Ngatunga I am not broadcasting this because it has real names of >the health facilities. I need more clarifications.

>

> Are private health facilities excluded in reporting MTUHA data?

>Bagamoyo district has 42 health facilities. My DHIS is telling me that
>20 health facilities did not submit all four reports (DHIS put "1" for
>outstanding reports). In these 20 non-reporting health facilities, 13
>(the highlighted ones) have never submitted a single report in the year
>2001 and they seems to be private facilities. I read in MTUHA
>implementation plan 1992 - 1996 (MoH-TZ, 1993) that all private
>facilities must report MTUHA data. Are private facilities still under
>mandate to report? If yes what could be the possible reason that they
>did not report?

>

> How do the health facilities send reports to the district, and
>district to the region, and region to the MoH. DMOs visit the health
>facilities to collect the reports or facilities bike to the district to
>submit reports?

>

> Regards

>

> Lungo

APPENDIX F

SPSS OUTPUTS ON ANALYSIS OF THE QUESTIONNAIRE

Table 1: Interview participants

Type of Organisation	Frequency	Percent
Dispensary	2	6.3
Health Centre	6	18.8
Hospital	2	6.3
DMO – District Medical office	5	15.6
RMO – Regional Medical Office	2	6.3
MoH – Ministry of Health	7	21.9
NGO	8	25.0
Total	32	100.0

Table 2: Type of Organisation * Respondent's Sex Crosstabulation

Type of Organisation	Respondent's Sex		Total
	Male	Female	
Dispensary	1	1	2
Health Centre	3	3	6
Hospital	1	1	2
DMO	5		5
RMO	1	1	2
MoH	6	1	7
NGO	5	3	8
Total	22	10	32

Table 3: Respondent's sex distributions

Respondent's Sex	Frequency	Percent
Male	22	68.8
Female	10	31.3
Total	32	100.0

Table 4: Type of Organisation * Respondent's Education Level Crosstabulation

Type of Organisation	Respondent's Education Level				Total
	Primary	O-Level Secondary	A-Level Secondary	University/college Level	
Dispensary	1	1			2
Health Centre		2	3	1	6
Hospital		1	1		2
DMO			1	4	5
RMO				2	2
MoH		2		5	7
NGO				8	8
Total	1	6	5	20	32

Table 5: Respondent's Education Level

Respondent's Education Level	Frequency	Percent
Primary	1	3.1
O-Level Secondary	6	18.8
A-Level Secondary	5	15.6
University/college Level	20	62.5
Total	32	100.0

Table 6: Type of Organisation * Respondent's Occupation Crosstabulation

Type of Organisation	Respondent's Occupation				Total
	Health Worker (Doctors/ Nurses/ Matron)	Medical officer/ Assistant Medical officer	Data manager/ statistician	Manager/ Director	
Dispensary	2				2
Health Centre	3	3			6
Hospital	2				2
DMO		4	1		5
RMO		1	1		2
MoH		1	4	2	7
NGO	1		4	3	8
Total	8	9	10	5	32

Table 7: Respondent's Occupation

	Frequency	Percent
Health Worker (Doctors/Nurses/Matron)	8	25.0
Medical officer/Assistant Medical officer	9	28.1
Data manager/statistician	10	31.3
Manager/Director	5	15.6
Total	32	100.0

STRENGTH OF HMIS IN DATA COLLECTION

Table 8: Type of Organisation * Who collects data? Crosstabulation

Type of Organisation		Who collects data?			Total
		Health Workers	Data manager/ statistician	Any One	
Dispensary	Count	1		1	2
	% within Type of Organisation	50.0%		50.0%	100.0%
Health Centre	Count	3		3	6
	% within Type of Organisation	50.0%		50.0%	100.0%
Hospital	Count	2			2
	% within Type of Organisation	100.0%			100.0%
DMO	Count	4	1		5
	% within Type of Organisation	80.0%	20.0%		100.0%
RMO	Count	1	1		2
	% within Type of Organisation	50.0%	50.0%		100.0%
MoH	Count		7		7
	% within Type of Organisation		100.0%		100.0%
NGO	Count		8		8
	% within Type of Organisation		100.0%		100.0%
Total	Count	11	17	4	32
	% within Type of Organisation	34.4%	53.1%	12.5%	100.0%

Table 9: Type of Organisation * Type of Data being collected Crosstabulation

Type of Organisation		Type of Data being collected				Total
		HMIS data	DSS	IDWE	All	
Dispensary	Count	2				2
	% within Type of Organisation	100.0%				100.0%
Health Centre	Count	6				6
	% within Type of Organisation	100.0%				100.0%
Hospital	Count	2				2
	% within Type of Organisation	100.0%				100.0%
DMO	Count	3			2	5
	% within Type of Organisation	60.0%			40.0%	100.0%
RMO	Count				2	2
	% within Type of Organisation				100.0%	100.0%
MoH	Count				7	7
	% within Type of Organisation				100.0%	100.0%
NGO	Count		7	1		8
	% within Type of Organisation		87.5%	12.5%		100.0%
Total	Count	13	7	1	11	32
	% within Type of Organisation	40.6%	21.9%	3.1%	34.4%	100.0%

Table 10: Type of Organisation * Source of data Crosstabulation

Type of Organisation		Source of data			Total
		Health Facility	Community	All	
Dispensary	Count	1		1	2
	% within Type of Organisation	50.0%		50.0%	100.0%
Health Centre	Count	6			6
	% within Type of Organisation	100.0%			100.0%
Hospital	Count	1		1	2
	% within Type of Organisation	50.0%		50.0%	100.0%
DMO	Count	2		3	5
	% within Type of Organisation	40.0%		60.0%	100.0%
RMO	Count			2	2
	% within Type of Organisation			100.0%	100.0%
MoH	Count	1		6	7
	% within Type of Organisation	14.3%		85.7%	100.0%
NGO	Count		7	1	8
	% within Type of Organisation		87.5%	12.5%	100.0%
Total	Count	11	7	14	32
	% within Type of Organisation	34.4%	21.9%	43.8%	100.0%

Table 11: Type of Organisation * Availability of Data Registers Crosstabulation

Type of Organisation		Availability of Data Registers			Total
		All the time	Some time	N/A	
Dispensary	Count		2		2
	% within Type of Organisation		100.0%		100.0%
Health Centre	Count		6		6
	% within Type of Organisation		100.0%		100.0%
Hospital	Count		2		2
	% within Type of Organisation		100.0%		100.0%
DMO	Count	1	4		5
	% within Type of Organisation	20.0%	80.0%		100.0%

RMO	Count		1	1	2
	% within Type of Organisation		50.0%	50.0%	100.0%
MoH	Count	1	1	5	7
	% within Type of Organisation	14.3%	14.3%	71.4%	100.0%
NGO	Count			8	8
	% within Type of Organisation			100.0%	100.0%
Total	Count	2	16	14	32
	% within Type of Organisation	6.3%	50.0%	43.8%	100.0%

Table 12: Defined Reporting Format

	Frequency	Percent
Yes	24	75.0
No	6	18.8
Don't Know	2	6.3
Total	32	100.0

ANALYSIS OF HEALTH DATA

Table 12: Type of Organisation * Availability of data analysis tools Crosstabulation

Type of Organisation		Availability of data analysis tools			Total
		Yes	No	N/A	
Dispensary	Count		2		2
	% within Type of Organisation		100.0%		100.0%
Health Centre	Count	1	5		6
	% within Type of Organisation	16.7%	83.3%		100.0%
Hospital	Count	2			2
	% within Type of Organisation	100.0%			100.0%
DMO	Count	5			5
	% within Type of Organisation	100.0%			100.0%
RMO	Count	2			2
	% within Type of Organisation	100.0%			100.0%
MoH	Count	7			7
	% within Type of Organisation	100.0%			100.0%
NGO	Count			8	8
	% within Type of Organisation			100.0%	100.0%
Total	Count	17	7	8	32
	% within Type of Organisation	53.1%	21.9%	25.0%	100.0%

Table 13: Type of Organisation * Capacity of the Data analysis tools Crosstabulation

Type of Organisation		Capacity of the Data analysis tools			Total
		Good	Not enough	N/A	
Dispensary	Count			2	2
	% within Type of Organisation			100.0%	100.0%
Health Centre	Count		1	5	6
	% within Type of Organisation		16.7%	83.3%	100.0%
Hospital	Count		2		2
	% within Type of Organisation		100.0%		100.0%
DMO	Count	1	4		5
	% within Type of Organisation	20.0%	80.0%		100.0%
RMO	Count		2		2
	% within Type of Organisation		100.0%		100.0%
MoH	Count	5	2		7

	% within Type of Organisation	71.4%	28.6%		100.0%
NGO	Count			8	8
	% within Type of Organisation			100.0%	100.0%
Total	Count	6	11	15	32
	% within Type of Organisation	18.8%	34.4%	46.9%	100.0%

Table 14: Type of Organisation * Data Manager/Statistician availability Crosstabulation

Type of Organisation		Data Manager/Statistician availability		Total
		Yes	No	
Dispensary	Count		2	2
	% within Type of Organisation		100.0%	100.0%
Health Centre	Count	1	5	6
	% within Type of Organisation	16.7%	83.3%	100.0%
Hospital	Count	2		2
	% within Type of Organisation	100.0%		100.0%
DMO	Count	5		5
	% within Type of Organisation	100.0%		100.0%
RMO	Count	2		2
	% within Type of Organisation	100.0%		100.0%
MoH	Count	7		7
	% within Type of Organisation	100.0%		100.0%
NGO	Count	8		8
	% within Type of Organisation	100.0%		100.0%
Total	Count	25	7	32
	% within Type of Organisation	78.1%	21.9%	100.0%

Table 15: Type of Organisation * Trained to Manage/Analyse data Crosstabulation

Type of Organisation		Trained to Manage/Analyse data			Total
		Yes	No	N/A	
Dispensary	Count	1	1		2
	% within Type of Organisation	50.0%	50.0%		100.0%
Health Centre	Count	6			6
	% within Type of Organisation	100.0%			100.0%
Hospital	Count	2			2
	% within Type of Organisation	100.0%			100.0%
DMO	Count	5			5
	% within Type of Organisation	100.0%			100.0%
RMO	Count	2			2
	% within Type of Organisation	100.0%			100.0%
MoH	Count	5	1	1	7
	% within Type of Organisation	71.4%	14.3%	14.3%	100.0%
NGO	Count	5		3	8
	% within Type of Organisation	62.5%		37.5%	100.0%
Total	Count	26	2	4	32
	% within Type of Organisation	81.3%	6.3%	12.5%	100.0%

COMPUTER

Table 16: Type of Organisation * Computer Available for Data Analysis Crosstabulation

Type of Organisation	Computer Available for Data Analysis			Total
	Yes	No	N/A	

Dispensary	Count		1	1	2
	% within Type of Organisation		50.0%	50.0%	100.0%
Health Centre	Count		6		6
	% within Type of Organisation		100.0%		100.0%
Hospital	Count		2		2
	% within Type of Organisation		100.0%		100.0%
DMO	Count	2	3		5
	% within Type of Organisation	40.0%	60.0%		100.0%
RMO	Count	2			2
	% within Type of Organisation	100.0%			100.0%
MoH	Count	7			7
	% within Type of Organisation	100.0%			100.0%
NGO	Count	8			8
	% within Type of Organisation	100.0%			100.0%
Total	Count	19	12	1	32
	% within Type of Organisation	59.4%	37.5%	3.1%	100.0%

Table 17: Type of Organisation * Performance of the Computer System Crosstabulation

Type of Organisation		Performance of the Computer System			Total
		Good	Poor	N/A	
Dispensary	Count			2	2
	% within Type of Organisation			100.0%	100.0%
Health Centre	Count			6	6
	% within Type of Organisation			100.0%	100.0%
Hospital	Count			2	2
	% within Type of Organisation			100.0%	100.0%
DMO	Count	1	1	3	5
	% within Type of Organisation	20.0%	20.0%	60.0%	100.0%
RMO	Count		2		2
	% within Type of Organisation		100.0%		100.0%
MoH	Count	3	4		7
	% within Type of Organisation	42.9%	57.1%		100.0%
NGO	Count	8			8
	% within Type of Organisation	100.0%			100.0%
Total	Count	12	7	13	32
	% within Type of Organisation	37.5%	21.9%	40.6%	100.0%

Table 18: Type of Organisation * Computer Training Adequate Crosstabulation

Type of Organisation		Computer Training Adequate			Total
		Yes	No	N/A	
Dispensary	Count			2	2
	% within Type of Organisation			100.0%	100.0%
Health Centre	Count			6	6
	% within Type of Organisation			100.0%	100.0%
Hospital	Count			2	2
	% within Type of Organisation			100.0%	100.0%
DMO	Count	1	1	3	5
	% within Type of Organisation	20.0%	20.0%	60.0%	100.0%
RMO	Count		2		2
	% within Type of Organisation		100.0%		100.0%
MoH	Count	6		1	7

	% within Type of Organisation	85.7%		14.3%	100.0%
NGO	Count	6		2	8
	% within Type of Organisation	75.0%		25.0%	100.0%
Total	Count	13	3	16	32
	% within Type of Organisation	40.6%	9.4%	50.0%	100.0%

ACCESSING HEALTH DATA

Table 19: Type of Organisation * Means of Data Storage Crosstabulation

Type of Organisation		Means of Data Storage			Total
		Paper/ Manual	Computer/E lectronic	Both	
Dispensary	Count	2			2
	% within Type of Organisation	100.0%			100.0%
Health Centre	Count	6			6
	% within Type of Organisation	100.0%			100.0%
Hospital	Count		1	1	2
	% within Type of Organisation		50.0%	50.0%	100.0%
DMO	Count	2	1	2	5
	% within Type of Organisation	40.0%	20.0%	40.0%	100.0%
RMO	Count			2	2
	% within Type of Organisation			100.0%	100.0%
MoH	Count		2	5	7
	% within Type of Organisation		28.6%	71.4%	100.0%
NGO	Count		7	1	8
	% within Type of Organisation		87.5%	12.5%	100.0%
Total	Count	10	11	11	32
	% within Type of Organisation	31.3%	34.4%	34.4%	100.0%

Table 20: Type of Organisation * Means of Dissemination Data Crosstabulation

Type of Organisation		Means of Dissemination Data			Total
		hardcopy	softcopy	Both	
Dispensary	Count	2			2
	% within Type of Organisation	100.0%			100.0%
Health Centre	Count	6			6
	% within Type of Organisation	100.0%			100.0%
Hospital	Count	2			2
	% within Type of Organisation	100.0%			100.0%
DMO	Count	4	1		5
	% within Type of Organisation	80.0%	20.0%		100.0%
RMO	Count		1	1	2
	% within Type of Organisation		50.0%	50.0%	100.0%
MoH	Count	4		3	7
	% within Type of Organisation	57.1%		42.9%	100.0%
NGO	Count	7		1	8
	% within Type of Organisation	87.5%		12.5%	100.0%
Total	Count	25	2	5	32
	% within Type of Organisation	78.1%	6.3%	15.6%	100.0%

Table 21: Type of Organisation * Time taken to retrieve Data Crosstabulation

Type of Organisation	Time taken to retrieve Data		Total
	Easily Accessible	Difficulty to Access	

Dispensary	Count	1	1	2
	% within Type of Organisation	50.0%	50.0%	100.0%
Health Centre	Count	5	1	6
	% within Type of Organisation	83.3%	16.7%	100.0%
Hospital	Count	1	1	2
	% within Type of Organisation	50.0%	50.0%	100.0%
DMO	Count		5	5
	% within Type of Organisation		100.0%	100.0%
RMO	Count	2		2
	% within Type of Organisation	100.0%		100.0%
MoH	Count	6	1	7
	% within Type of Organisation	85.7%	14.3%	100.0%
NGO	Count	8		8
	% within Type of Organisation	100.0%		100.0%
Total	Count	23	9	32
	% within Type of Organisation	71.9%	28.1%	100.0%

Table 22: Type of Organisation * Receiving feedback Crosstabulation

Type of Organisation		Receiving feedback			Total
		Yes	No	N/A	
Dispensary	Count	1	1		2
	% within Type of Organisation	50.0%	50.0%		100.0%
Health Centre	Count	6			6
	% within Type of Organisation	100.0%			100.0%
Hospital	Count	2			2
	% within Type of Organisation	100.0%			100.0%
DMO	Count	4	1		5
	% within Type of Organisation	80.0%	20.0%		100.0%
RMO	Count	2			2
	% within Type of Organisation	100.0%			100.0%
MoH	Count			7	7
	% within Type of Organisation			100.0%	100.0%
NGO	Count			8	8
	% within Type of Organisation			100.0%	100.0%
Total	Count	15	2	15	32
	% within Type of Organisation	46.9%	6.3%	46.9%	100.0%

USING OF HEALTH DATA COLLECTED

Table 23: Information sharing practices

	Frequency	Percent
Yes	26	81.3
No	6	18.8
Total	32	100.0

Table 24: Format of documents shared

	Frequency	Percent	Valid Percent	Cumulative Percent
Hardcopy	16	50.0	50.0	50.0
Both softcopy and hardcopy	10	31.3	31.3	81.3
N/A	6	18.8	18.8	100.0
Total	32	100.0	100.0	

Table 25: Evidence of Information use

	Frequency	Percent	Valid Percent	Cumulative Percent
Yes	27	84.4	84.4	84.4
No	5	15.6	15.6	100.0
Total	32	100.0	100.0	

Table 26: Researcher satisfaction from HMIS data

	Frequency	Percent	Valid Percent	Cumulative Percent
Yes	13	40.6	40.6	40.6
No	14	43.8	43.8	84.4
N/A	5	15.6	15.6	100.0
Total	32	100.0	100.0	

ATTITUDE OF HEALTH WORKERS TOWARDS HEALTH DATA EFFORTS

Table 27: Type of Organisation * Time used to collect data Crosstabulation

Type of Organisation		Time used to collect data			Total
		Too much time	Little time	N/A	
Dispensary	Count	2			2
	% within Type of Organisation	100.0%			100.0%
Health Centre	Count	5	1		6
	% within Type of Organisation	83.3%	16.7%		100.0%
Hospital	Count	2			2
	% within Type of Organisation	100.0%			100.0%
DMO	Count	5			5
	% within Type of Organisation	100.0%			100.0%
RMO	Count	1	1		2
	% within Type of Organisation	50.0%	50.0%		100.0%
MoH	Count	5		2	7
	% within Type of Organisation	71.4%		28.6%	100.0%
NGO	Count	8			8
	% within Type of Organisation	100.0%			100.0%
Total	Count	28	2	2	32
	% within Type of Organisation	87.5%	6.3%	6.3%	100.0%

Table 28: Type of Organisation * Time used to analyse data Crosstabulation

Type of Organisation		Time used to analyse data			Total
		Too much time	Little time	N/A	
Dispensary	Count	2			2
	% within Type of Organisation	100.0%			100.0%
Health Centre	Count	4	1	1	6
	% within Type of Organisation	66.7%	16.7%	16.7%	100.0%
Hospital	Count	2			2
	% within Type of Organisation	100.0%			100.0%
DMO	Count	4	1		5
	% within Type of Organisation	80.0%	20.0%		100.0%
RMO	Count	2			2
	% within Type of Organisation	100.0%			100.0%
MoH	Count	5		2	7
	% within Type of Organisation	71.4%		28.6%	100.0%
NGO	Count	7	1		8

	% within Type of Organisation	87.5%	12.5%		100.0%
Total	Count	26	3	3	32
	% within Type of Organisation	81.3%	9.4%	9.4%	100.0%

Table 29: Type of Organisation * Staff Work load Crosstabulation

Type of Organisation		Staff Work load		Total
		Overloaded	Satisfactory	
Dispensary	Count	2		2
	% within Type of Organisation	100.0%		100.0%
Health Centre	Count	6		6
	% within Type of Organisation	100.0%		100.0%
Hospital	Count	2		2
	% within Type of Organisation	100.0%		100.0%
DMO	Count	5		5
	% within Type of Organisation	100.0%		100.0%
RMO	Count	1	1	2
	% within Type of Organisation	50.0%	50.0%	100.0%
MoH	Count	6	1	7
	% within Type of Organisation	85.7%	14.3%	100.0%
NGO	Count		8	8
	% within Type of Organisation		100.0%	100.0%
Total	Count	22	10	32
	% within Type of Organisation	68.8%	31.3%	100.0%

Table 30: Design of the Data Registers

	Frequency	Percent	Valid Percent	Cumulative Percent
Simple & Complete	16	50.0	50.0	50.0
Simple but not Complete	13	40.6	40.6	90.6
Confusing	1	3.1	3.1	93.8
N/A	2	6.3	6.3	100.0
Total	32	100.0	100.0	

Table 31: Type of Organisation * Performance of HMIS Database Crosstabulation

Type of Organisation		Performance of HMIS Database			Total
		Good	Not Good	N/A	
Dispensary	Count			2	2
	% within Type of Organisation			100.0%	100.0%
Health Centre	Count			6	6
	% within Type of Organisation			100.0%	100.0%
Hospital	Count			2	2
	% within Type of Organisation			100.0%	100.0%
DMO	Count			5	5
	% within Type of Organisation			100.0%	100.0%
RMO	Count		2		2
	% within Type of Organisation		100.0%		100.0%
MoH	Count	2	5		7
	% within Type of Organisation	28.6%	71.4%		100.0%
NGO	Count		1	7	8
	% within Type of Organisation		12.5%	87.5%	100.0%
Total	Count	2	8	22	32
	% within Type of Organisation	6.3%	25.0%	68.8%	100.0%